

DRAGON MEDIUM ANTITANK/ASSAULT WEAPON SYSTEM M47

CONTENTS

	Page
Preface	v
Chapter 1. INTRODUCTION	1-1
1-1. Characteristics	1-1
1-2. Major Components	1-2
1-3. Support Equipment (M113-Equipped Units Only)	1-8
1-4. Training Strategy	1-11
1-5. Unit Training Programs	1-12
Chapter 2. SAFETY	2-1
2-1. Safety Precautions	2-1
2-2. Round Handling	2-3
2-3. Firing Limitations	2-3
2-4. Fighting Position	2-3
2-5. Firing Over Water	2-3
2-6. Training Equipment	2-4
Chapter 3. EMPLOYMENT OF THE DRAGON	3-1
Section I. Dragon Role and Personnel Duties	3-1
3-1. Dragon Role	3-1
3-2. Organization Within Antiarmor Section	3-1
3-3. Personnel Duties	3-4
Section II. Employment of Dragon in the Defense	3-6
3-4. Considerations	3-6
3-5. Defensive Operations	3-7
3-6. Firing Positions	3-7
3-7. Dragon Positioning	3-8
3-8. Positioning Considerations	3-10
3-9. Preparation of Dragon Fighting Positions	3-12
3-10. Firing From the M113 APC	3-16
3-11. Preparation of Range Cards	3-18
3-12. Target Identification	3-19
3-13. Target Recognition by Type (Friendly or Threat)	3-20
3-14. Thermal Identification	3-21

DISTRIBUTION RESTRICTION: Distribution authorized to U.S. Government agencies only to protect the technical or operational information from automatic dissemination under the International Exchange Program or by other means. This determination was made on 19 February 1989. Other requests for this document will be referred to: Commandant, U.S. Army Infantry School, ATTN: ATSH-IN-S3, Fort Benning, GA 31905-5596.

DESTRUCTION NOTICE: Destroy by any method that will prevent disclosure of contents or reconstruction of the document.

*This publication supersedes TC 23-24, 30 August 1974.

	Page
Section III. Target Engagement	3-22
3-15. Target Engagement Techniques	3-22
3-16. Range Determination	3-22
3-17. Time/Space Factor	3-24
3-18. Vulnerable Points of Armored Vehicles	3-25
3-19. Fire Control	3-26
3-20. Platoon Fire Plan	3-31
3-21. Armor-Killer Team	3-33
Section IV. Employment in the Retrograde	3-37
3-22. Retrograde Operations	3-37
3-23. Delaying Operations	3-37
3-24. Withdrawal	3-38
Section V. Employment in the Offense	3-40
3-25. Movement to Contact	3-40
3-26. Conduct of the Day Attack	3-42
3-27. Conduct of the Night Attack	3-43
3-28. Consolidation and Reorganization	3-44
Chapter 4. OPERATION AND FUNCTIONS	4-1
4-1. Inspection	4-1
4-2. Carrying Positions	4-1
4-3. Preparation of the Round for Firing	4-2
4-4. Firing Positions	4-5
4-5. Target Acquisition and Evaluation	4-5
4-6. Missile Flight and Control	4-7
4-7. Failure to Fire	4-8
4-8. Dragon Restored to Carrying Configuration	4-8
4-9. Adverse Weather Conditions	4-9
Chapter 5. UNIT TRAINING	5-1
Section I. Commander's Responsibility	5-1
5-1. Training Goals and Program	5-1
5-2. Instructor Selection	5-2
5-3. Gunner Selection	5-2
Section II. Dragon Training Overview	5-2
5-4. Development of a Unit Training Program	5-3
5-5. Training for Specific Needs	5-7
5-6. Multilevel Training	5-7
5-7. Leader Training	5-8
5-8. Gunner Training	5-8
5-9. Team Training	5-10
5-10. Collective Training	5-11
5-11. Evaluation	5-11

	Page
Chapter 6. TRAINING EQUIPMENT AND INSTRUCTOR TRAINING	6-1
Section I. Gunnery Training Equipment	6-1
6-1. Launch Effects Trainer	6-1
6-2. AN/TSQ-1 Monitoring Set	6-4
6-3. M89 Infrared Transmitting Set	6-6
6-4. Field Handling Trainer	6-8
6-5. Launch Effects Simulator	6-8
Section II. Instructor Training	6-9
6-6. Training Objective 1	6-9
6-7. Training Objective 2	6-12
6-8. Training Objective 3	6-14
6-9. Training Objective 4	6-15
6-10. Training Objective 5	6-15
6-11. Training Objective 6	6-16
6-12. Training Objective 7	6-17
6-13. Training Objective 8	6-20
6-14. Training Objective 9	6-23
6-15. Training Objective 10	6-23
6-16. Training Objective 11	6-25
6-17. Training Objective 12	6-26
6-18. Training Objective 13	6-26
6-19. Training Objective 14	6-27
6-20. Training Objective 15	6-27
Chapter 7. INSTRUCTOR'S GUIDE TO EFFECTIVE TRAINING	7-1
7-1. Instructor Skills and Knowledge	7-1
7-2. Training Program Schedule	7-1
7-3. Individual Instructions	7-2
7-4. Training at 250 Meters	7-2
7-5. Training Sequence	7-2
7-6. Firing Positions Demonstrations	7-2
7-7. M113 Instructional Techniques	7-6
7-8. Sighting, Aiming, and Firing	7-8
7-9. Breath Control	7-8
7-10. Tracking Exercises	7-8
7-11. Range Requirements	7-9
7-12. Range Procedures	7-12
7-13. Postoperational Procedures	7-15
Chapter 8. GUNNER QUALIFICATION AND SUSTAINMENT	
TRAINING PROGRAMS	8-1
Section I. Gunner Qualification Program	8-1
8-1. Qualification Requirements	8-1
8-2. Program Execution	8-1
8-3. Skill and Knowledge Requirements	8-2
8-4. Suggested Sequence of Time and Events	8-5

	Page
Section II. Sustainment Training Program	8-9
8-5. Gunner Sustainment Program	8-9
8-6. Collective Training	8-11
Appendix A. Thermal Target Recognition, Identification, Engagement	A-1
Appendix B. Performance Test	B-1
Appendix C. Gunner Qualification/Verification With LET	C-1
Appendix D. Decontamination and Destruction Procedures	D-1
Glossary	Glossary-1
References	References-1
Index	Index-1

PREFACE

This manual provides guidance for use and employment of the guided missile system, surface attack: M47 (Dragon), a medium-range antiarmor weapon system. The information herein includes characteristics, nomenclature, and functions. A training program is presented to develop, evaluate, and maintain proficiency of Dragon gunners. The tactical employment procedures described within this manual do not cover all situations.

This manual should be used by leaders and members of units equipped with the guided missile system, surface attack: M47 (Dragon), to train and test individual gunners or teams. Also discussed are five key elements for maintaining combat proficiency with the Dragon:

- Technical and tactical information.
- A training program that stresses command involvement.
- Centralization of training.
- Gunner selection.
- Development of qualified trainers.

The proponent of this publication is HQ TRADOC. Submit changes for improving this publication on DA Form 2028 (Recommended Changes to Publications and Blank Forms) and forward it to:

**Commandant
US Army Infantry School
ATTN: ATSH-IN-S3
Fort Benning, Georgia 31905-5596**

Unless otherwise stated, whenever the masculine gender is used, both men and women are included.

INTRODUCTION

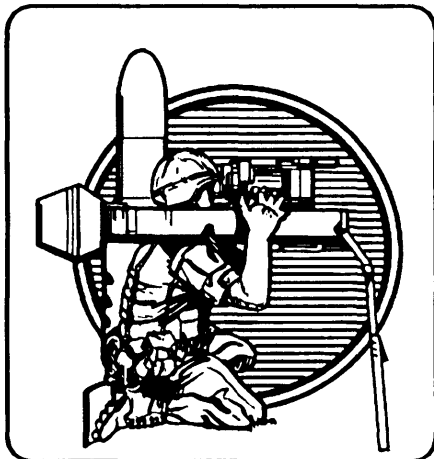

The guided missile system, surface attack: M47 (Dragon), is a man-portable, shoulder-fired, medium antitank weapon referred to in this manual as Dragon. It is capable of defeating armored vehicles, fortified bunkers, concrete gun emplacements, and other hardened targets on the battlefield. It can be operated by the individual soldier or by a two-man team. When employed with the mechanized infantry, it can be mounted and fired from the APC or M3 or M122 machine gun tripod, using the M175 mount. The Dragon can be fired using either the day tracker or night tracker, provided the gunner can see the target through the tracker. The Dragon night tracker (AN/TAS-5) increases the gunner's ability to engage targets during limited visibility. Targets can be engaged during daylight and also during limited visibility such as smoke, fog, or darkness.

1-1. CHARACTERISTICS

The Dragon consists of the following components: a day tracker, a night tracker, and a round of ammunition. The round is the expendable part of the system. The round has two major assemblies: the launcher and the missile. The launcher serves as the handling and carrying container and for firing the missile. The tracker is the reusable part of the system, which is designed for fast, easy detachment from the round. The tracker (day or night) determines any deviation of the missile from the LOS and generates correcting signals, which are sent to the missile control system by a wire link.

a. **Capabilities.** The Dragon is basically a defensive weapon that can be employed in all weather conditions and in any type of terrain. It is organic to infantry, armor, engineer, and field artillery units. The Dragon provides the mounted or dismounted soldier with a defense against hostile armor, during both day and night operations. The Dragon can be used during the assault against field fortifications, heavy weapon emplacements, and other hard-point targets. With its light weight, rapid deployment, and ease of operation, it is particularly suited for airborne and air mobile operations.

b. **Tracking and Controlling Capabilities.** The command LOS guidance system of the Dragon provides a high probability of hit. However, to achieve this, the gunner must be well trained on the steady-hold factors in Chapter 7. The gunner acquires the target in the tracker (day or night), and sets and holds the sight cross hairs center mass on the exposed portion of the target. This provides a continuous LOS for the tracker; other gunner control is required. The guidance and control is automatic until the missile impacts on the target. After the missile impacts, the gunner detaches the tracker, disposes of the

expended launcher, and prepares to fire another round.

c. **Mobility.** The system can be hand carried by one man. Therefore, the gunner/team chief can quickly displace to reduce the chance of detection or to engage targets that are not within the range of the primary fighting position.

d. **Rounds.** Three rounds are available for use with the Dragon: the M222 and MK1, MOD 0, tactical rounds (heat warheads), and M223 practice round (inert warhead). All rounds use the same basic airframe, aerodynamic control system, command-link wire, and missile electronics design.

e. **Equipment Data.** The following data describes the general and specific characteristics of the Dragon:

(1) *General.*

Minimum range - 65 meters.
 Maximum range - 1,000 meters.
 Ammunition - High-explosive antitank warhead or inert warhead.

(2) *Specific.*

Round: M222/M223 Weight - 14.6 kilograms (25.29 pounds). Missile Length - 744 millimeters (29.39 inches). Launcher Length - 1154 millimeters (44.1 inches).

Round: MK 1, MOD 0 Weight - 16.2 kilograms (27.2 pounds) Missile Length - 846 millimeters (33.32

inches) Launcher Length - 1154 millimeters (44.1 inches).

Day Tracker: Weight - 3.1 kilograms (6.75 pounds) Length - 196 millimeters (7.72 inches).

Night Tracker: Weight - 9.82 kilograms (21.65 pounds) Length - 368 millimeters (14.5 inches).

f. **Night Tracker Coolant Cartridge and Battery Carrying Container.** A mechanized infantry squad is issued five coolant cartridge packs and one battery carrying container full of components. A nonmechanized squad is issued five coolant cartridge packs and three battery carrying containers full of components.

1-2. MAJOR COMPONENTS

The Dragon weapon system consists of a day tracker, night tracker, and a round of ammunition.

a.. **Day Tracker Infrared Tracker G.M. SU-36/P.** The day tracker is an

electro-optical sight that determines the position of the missile relative to the gunner's LOS.

(1) The day tracker generates signals that are sent by wire to the control

system of the missile. The missile control system fires the appropriate rocket thrusters to keep the missile heading along the gunner's LOS (Figure 1-1).

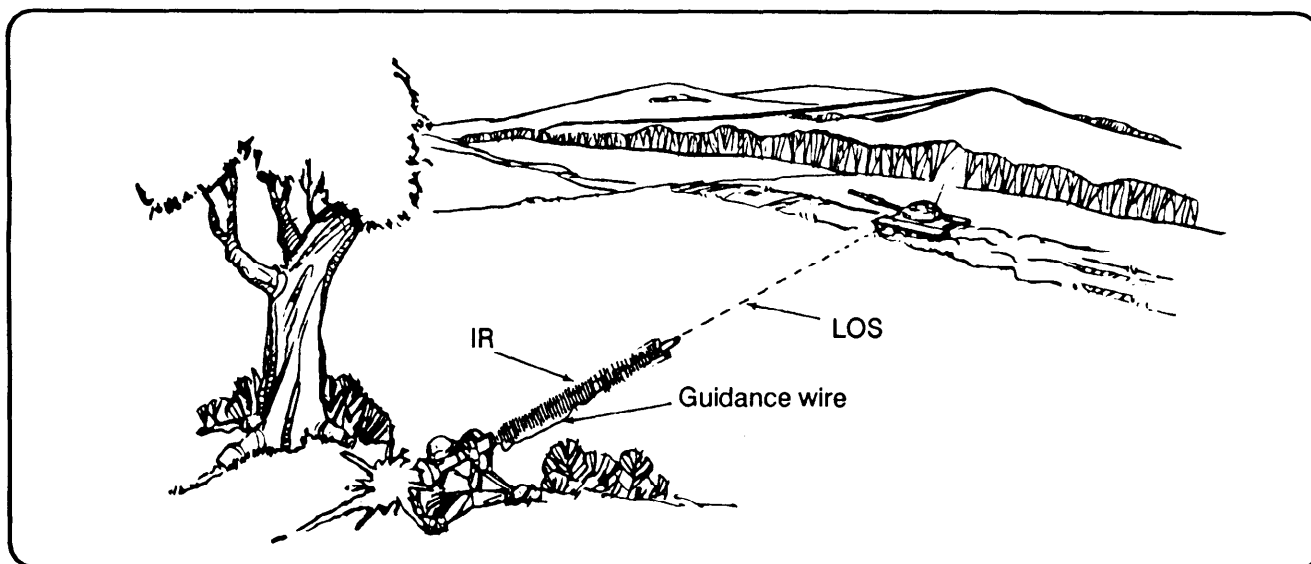

Figure 1-1. Day tracker line of sight.

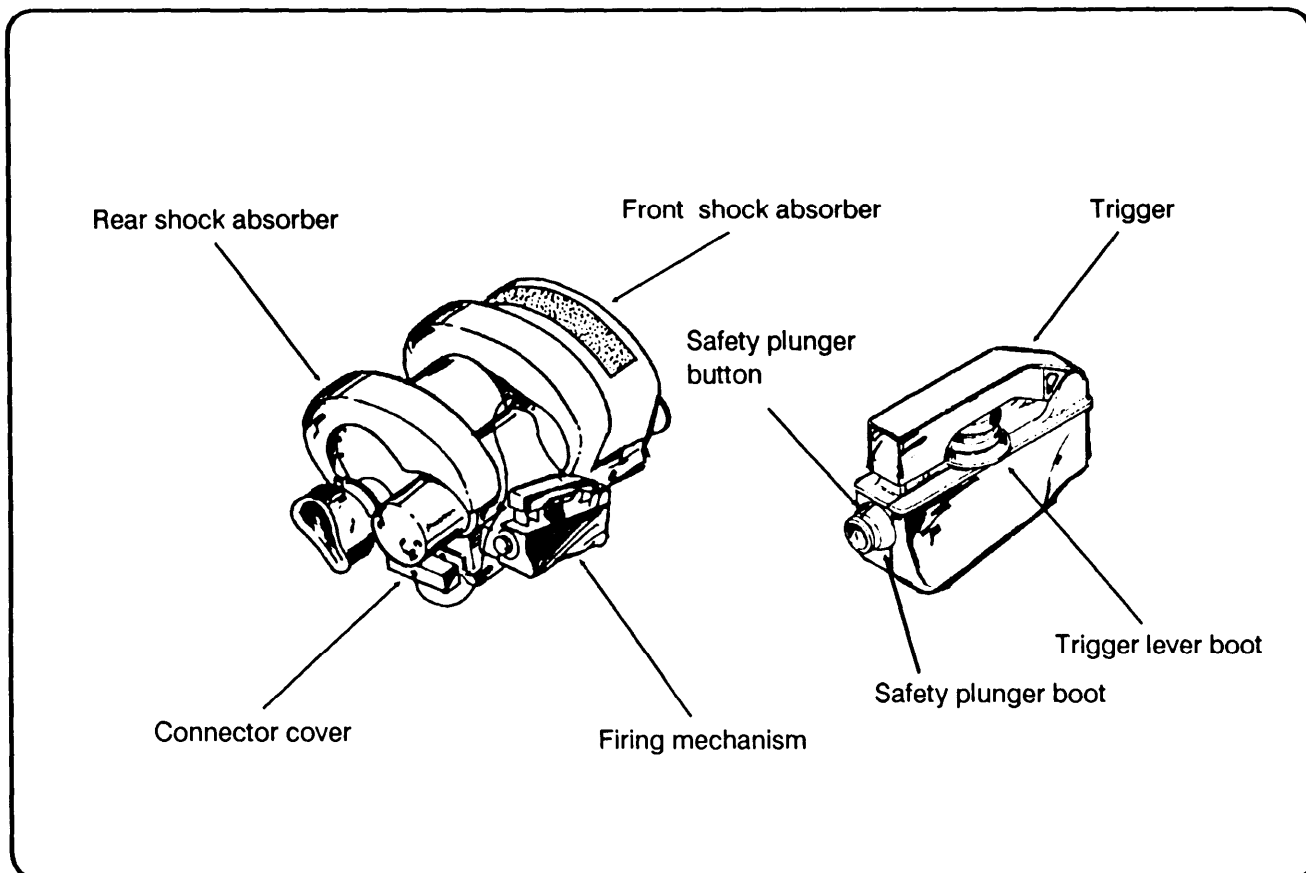

Figure 1-2. Day tracker parts.

(2) The day tracker is quickly attached to and removed from the round (Figure 1-2). The tracker has an aluminum housing assembly that contains an optical sight, infrared receiver assembly, and control signal comparator. On the right side of the housing is a firing mechanism. It consists of a trigger safety plunger and trigger level bar. The firing mechanism and safety plunger are protected by a moisture-seal rubber boot.

(3) A connector cover provides both mechanical and moisture protection for the electrical connector. It is attached to the tracker by a lanyard.

(4) Shock absorbers surround the forward and rear ends of the tracker

to protect the tracker and optical lenses. The lens cover is also attached to the tracker by a lanyard.

(5) The optical sight of the day tracker is a 6-power telescope. It provides the gunner with a magnified image across a 6-degree field of view to help him to locate, identify, and track targets. A fitted and molded rubber eye guard provides the gunner with eye protection and allows rapid eye adjustment to the sight (Figure 1-3). The infrared receiver consists of an objective lens assembly, graded filter, infrared detector, and nutator mirror. The sensor detects the infrared output of the missile flare and discriminates against background signals. It

detects any deviations or excursions of the missile from the gunner's LOS.

(6) The daytracker's telescopic sight and infrared receiver are aligned to define the LOS to the target. The sight reticle pattern is a tapered cross hair that causes the eye to concentrate on the center of the FOV. This aids the gunner to quickly adjust the center of the cross hairs and place them center mass of the target. A pair of stadia lines (Figure 1-4) are used to aid the gunner to determine the range of a target. The stadia lines are set up for the standard Threat vehicle (6 meters by 3 meters) at the maximum engagement range of 1,000 meters.

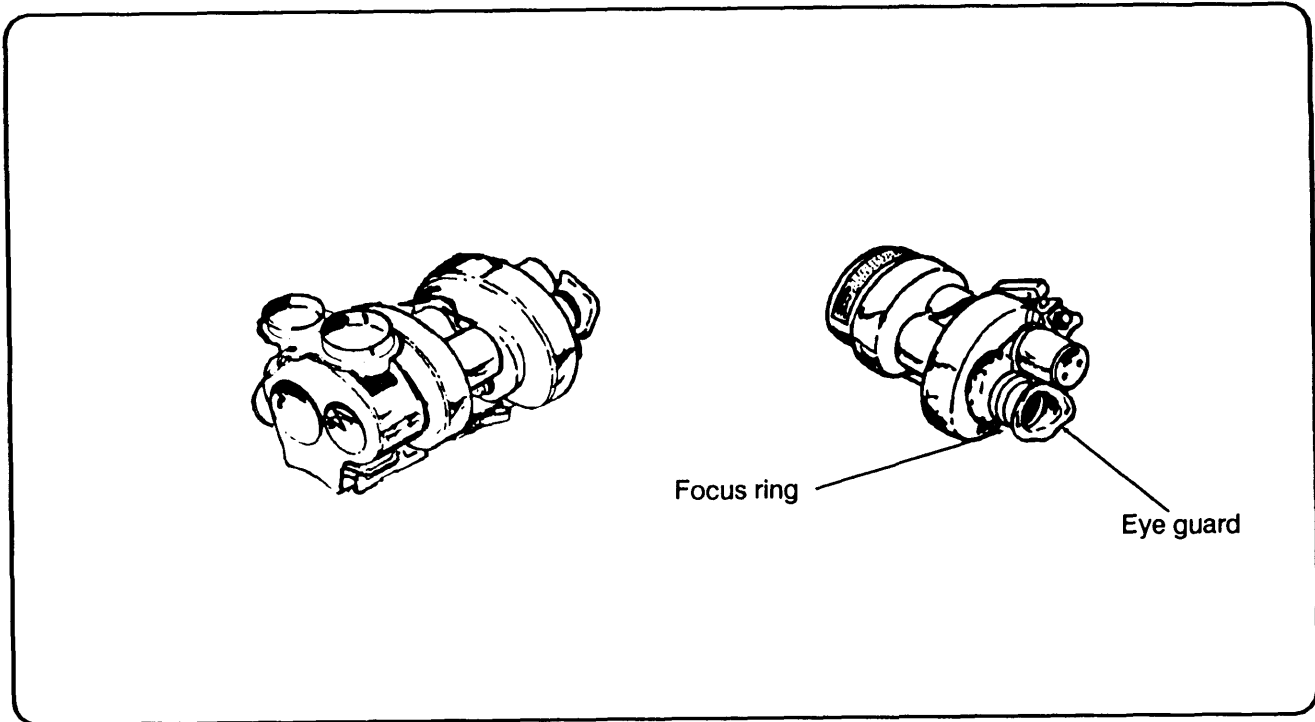

Figure 1-3. Day tracker optical sight and eye guard.

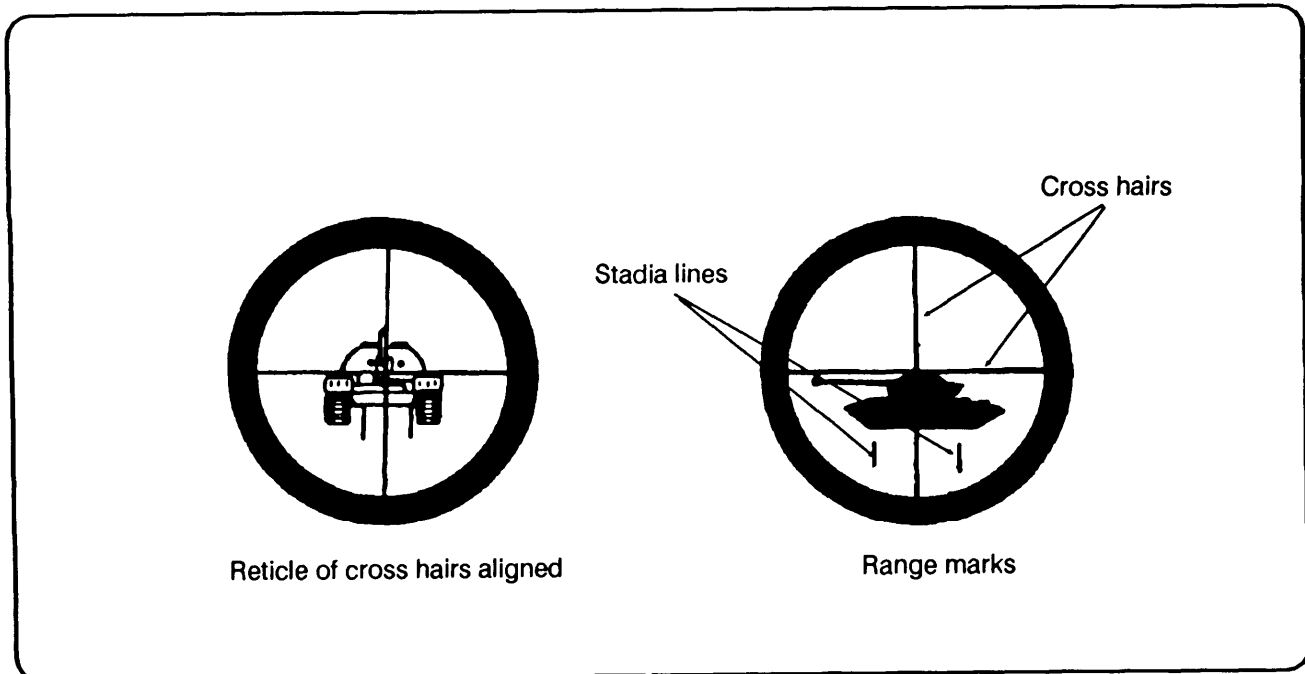

Figure 1-4. Day tracker reticle and stadia lines.

b. **Night Tracker (Night Vision Sight, Tracker, Infrared, AN/TAS-5).** The night tracker is used when light levels fall below that which is required for the day tracker (Figure 1-5).

(1) The AN/TAS-5 has a 4-power magnification and the FOV is 3.4 by 6.8 degrees. The night tracker is a passive device that receives heat emissions (infrared energy) from a target area (Figure 1-6), and converts the infrared energy to electrical signals and then to visible light. It displays the visible light as a real-time scene for viewing by the gunner. Objects that are warmer than the ambient temperature appear in the night tracker as varying shades of red; objects cooler than ambient temperature appear in the nightsight as black. The night tracker is a larger and heavier tracker than the day tracker, but performs the

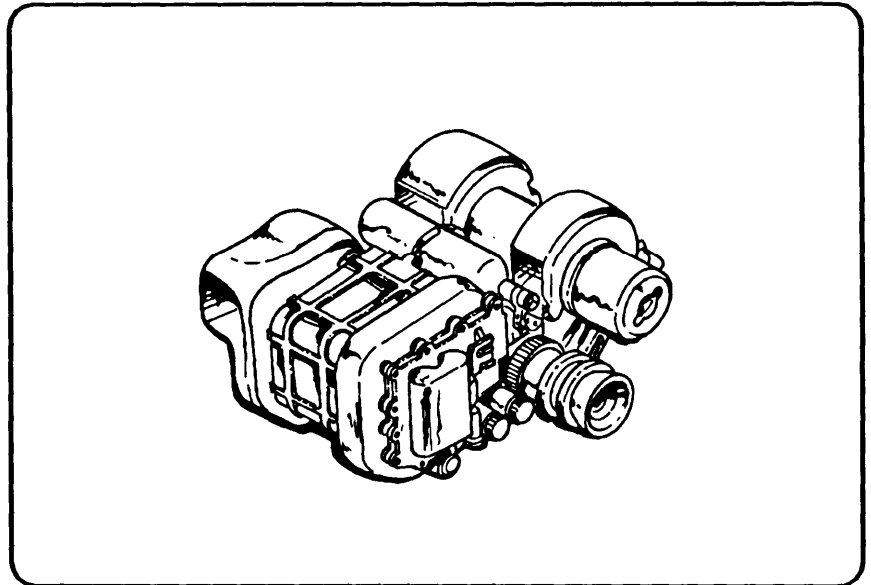

Figure 1-5. Night tracker.

same functions. The tracker helps the gunner to locate, identify, and track a target. The infrared tracker monitors the missile's flight and

provides the commands needed to keep the missile on the gunner's LOS.

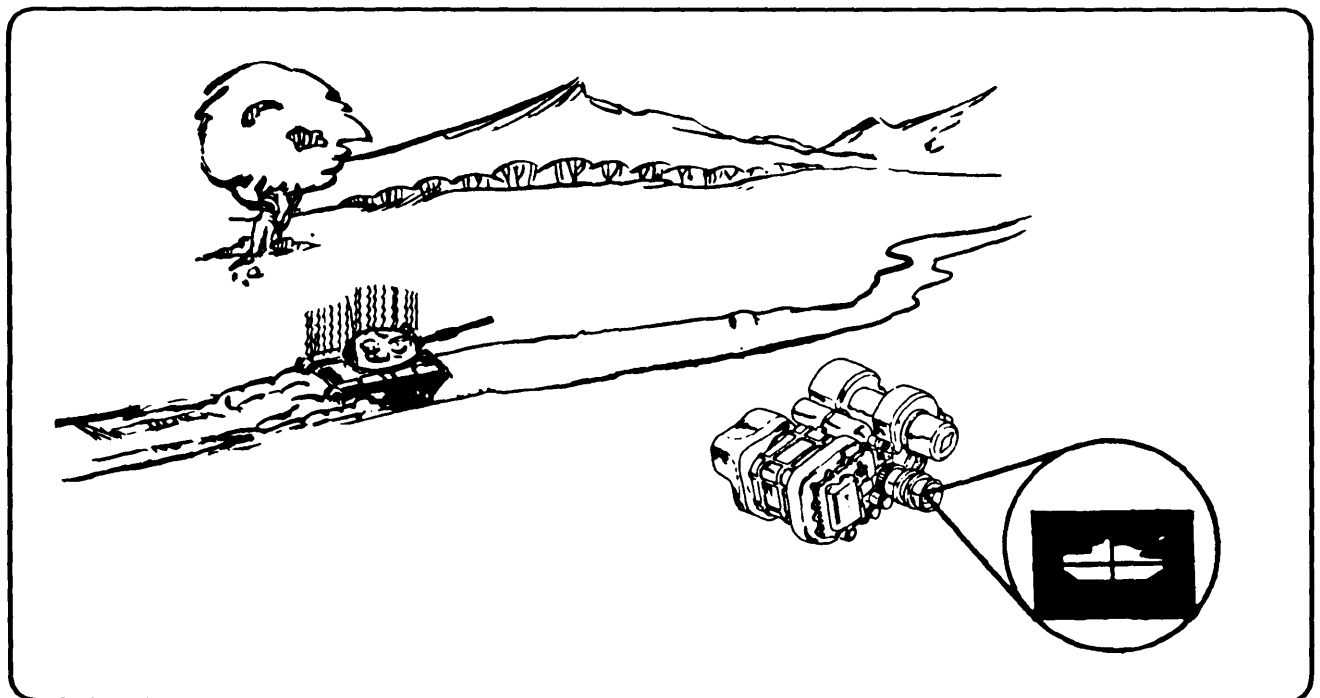

Figure 1-6. Night tracker senses infrared (heat).

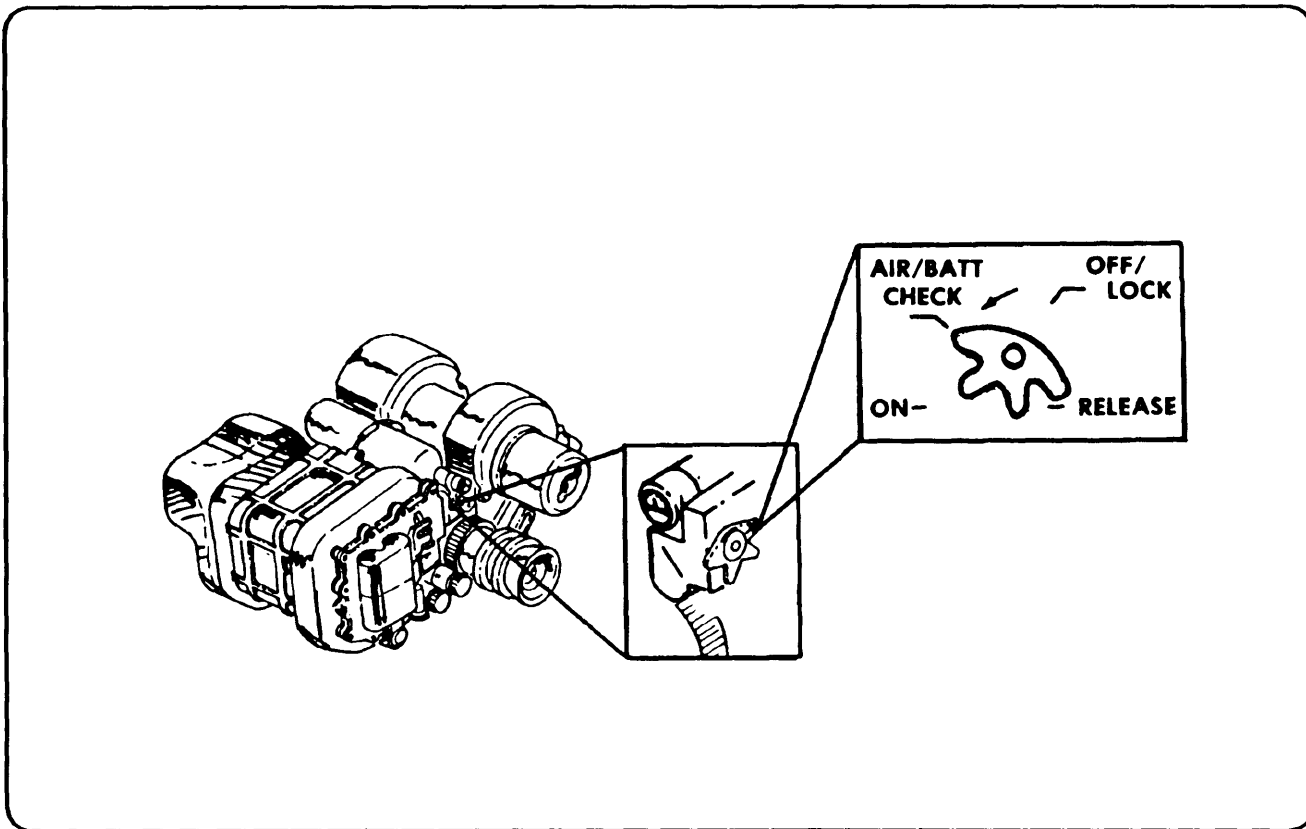

Figure 1-7. Night tracker actuator switch.

(2) The firing mechanism of the night tracker and the control and guidance are the same as with the day tracker.

(3) The night tracker is used during reduced visibility in day or night operations. It is capable of self-sustained operation, using an externally mounted 4.8-VDC battery and coolant cartridge, and can be operated using vehicle power and associated equipment installed in an APC. The gunner's operation of the night tracker differs from that of the day tracker. The night tracker has several controls not required on the day tracker.

(a) The ACTUATOR switch (Figure 1-7) turns the system on and off. It is a four-position switch that

permits the gunner to evaluate the operating condition of the night tracker, and is normally in the OFF-LOCK position. The switch is then rotated to the AIR-BATT-CHECK position used to check the condition of the coolant cartridge and battery. If the coolant cartridge and battery condition are good, the switch is rotated to the ON position for normal operation.

CAUTION: The fourth position, release, is used when the gunner must replace the coolant cartridge.

(b) The reticle adjustment ring focuses the reticle. The range focus lever adjusts the focus for different ranges. (Figure 1-8).

(c) The brightness and contrast controls (Figure 1-8) brighten or darken the picture, and the contrast control changes the contrast of the picture. Both the brightness and contrast adjustments work the same as similar controls on a television set.

c. Ammunition. The Dragon ammunition is an expendable component (Figure 1-9), consisting of the missile and launcher. The missile is installed in the launcher at the factory and shipped in a ready-to-fire configuration. The launcher serves as a storage and carrying case for the missile before launch.

(1) The launcher consists of a smoothbore, fiberglass tube, breech/gas pressure generator

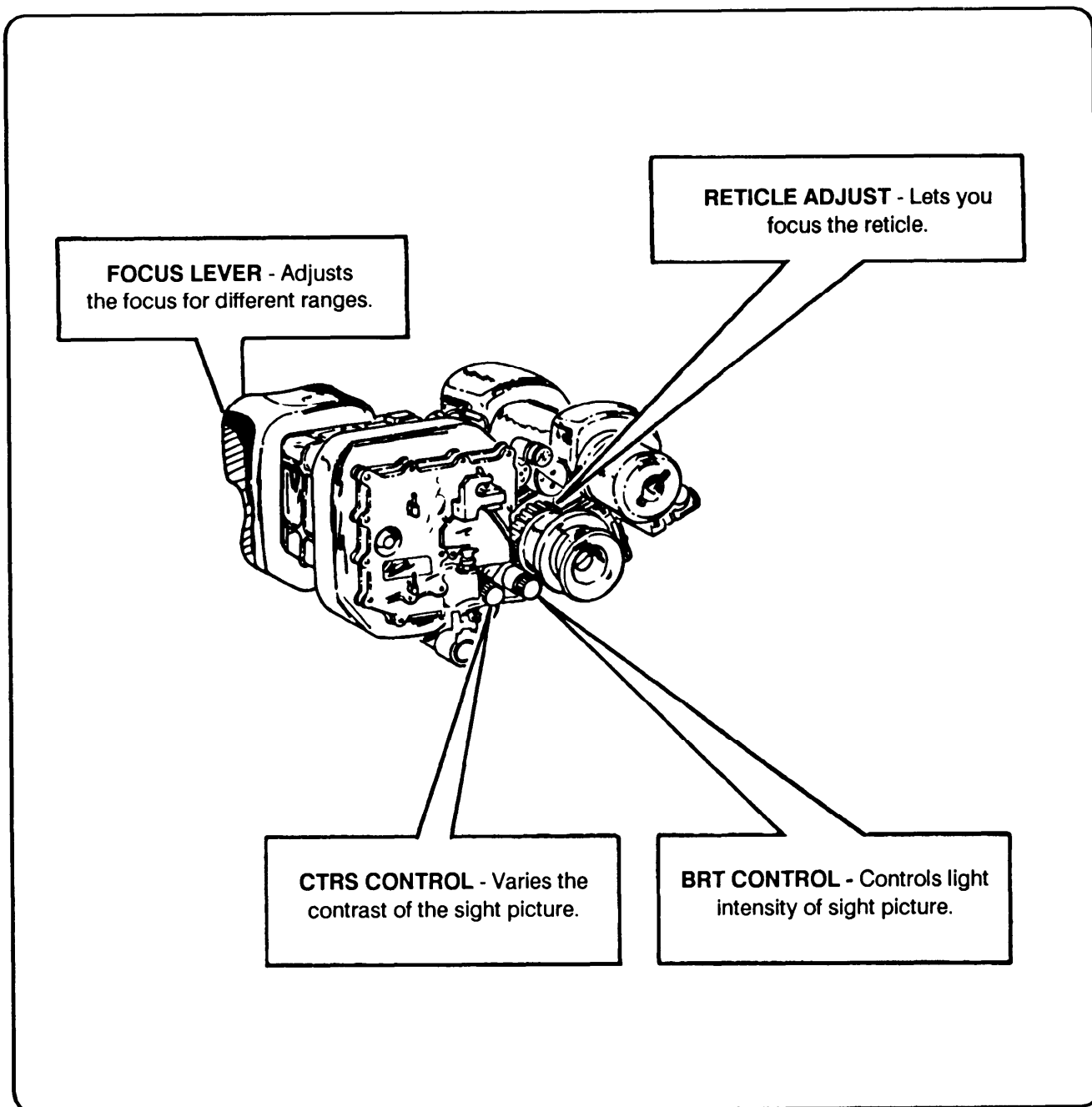

Figure 1-8. Night tracker controls.

assembly, wiring harness, tracker support assembly, biped, tracker battery, sling, and forward and rear shock absorbers.

(2) The tracker battery provides power to the tracker and fires the missile. The tracker bracket provides the electrical connections necessary for missile, trigger, and

tracker operation. The biped is attached to the forward end of the launcher and supports the launcher. The night tracker can then use APC power during mounted operations.

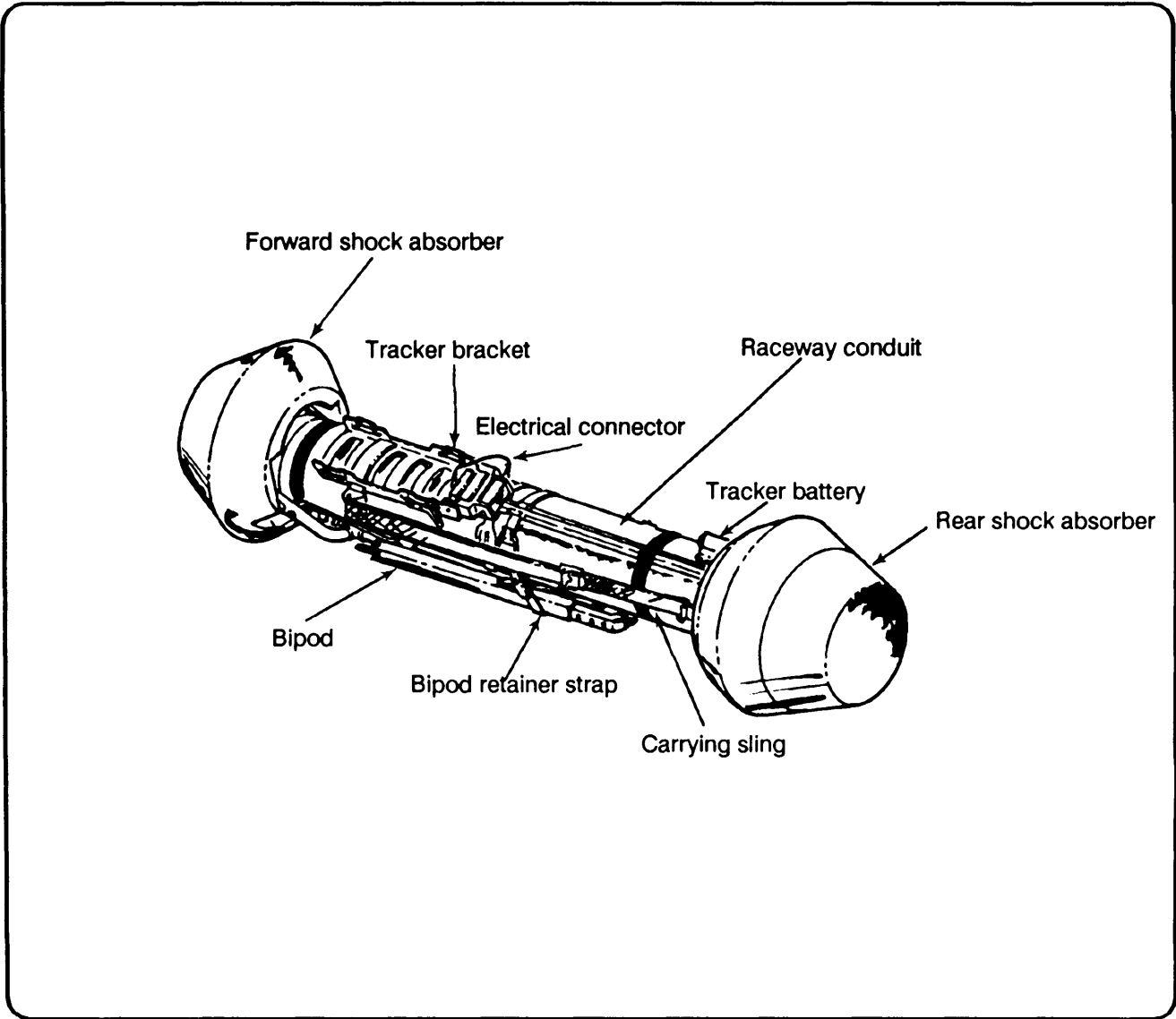

Figure 1-9. M222/MK1, MOD 0, tactical round external components.

1-3. SUPPORT EQUIPMENT (M113-EQUIPPED UNITS ONLY)

Units equipped with the M113 APC are authorized the following Dragon support equipment: guided missile launcher mount, M175, M3/M122 machine gun tripods, and vehicle storage kit.

a. **M175 Mounting Assembly.** The guided missile launcher mount

(Figure 1-10) provides a stable platform for firing the Dragon missile from the M113 APC and the M3 or M122 machine gun tripods. The M175 mounting assembly is installed on the APC by the unit track mechanic. If the APC is turned in for overhaul or repair, ensure the

unit track mechanic removes all support equipment.

(1) It provides improved, stable firing and tracking conditions for the gunner, thereby increasing weapon system effectiveness.

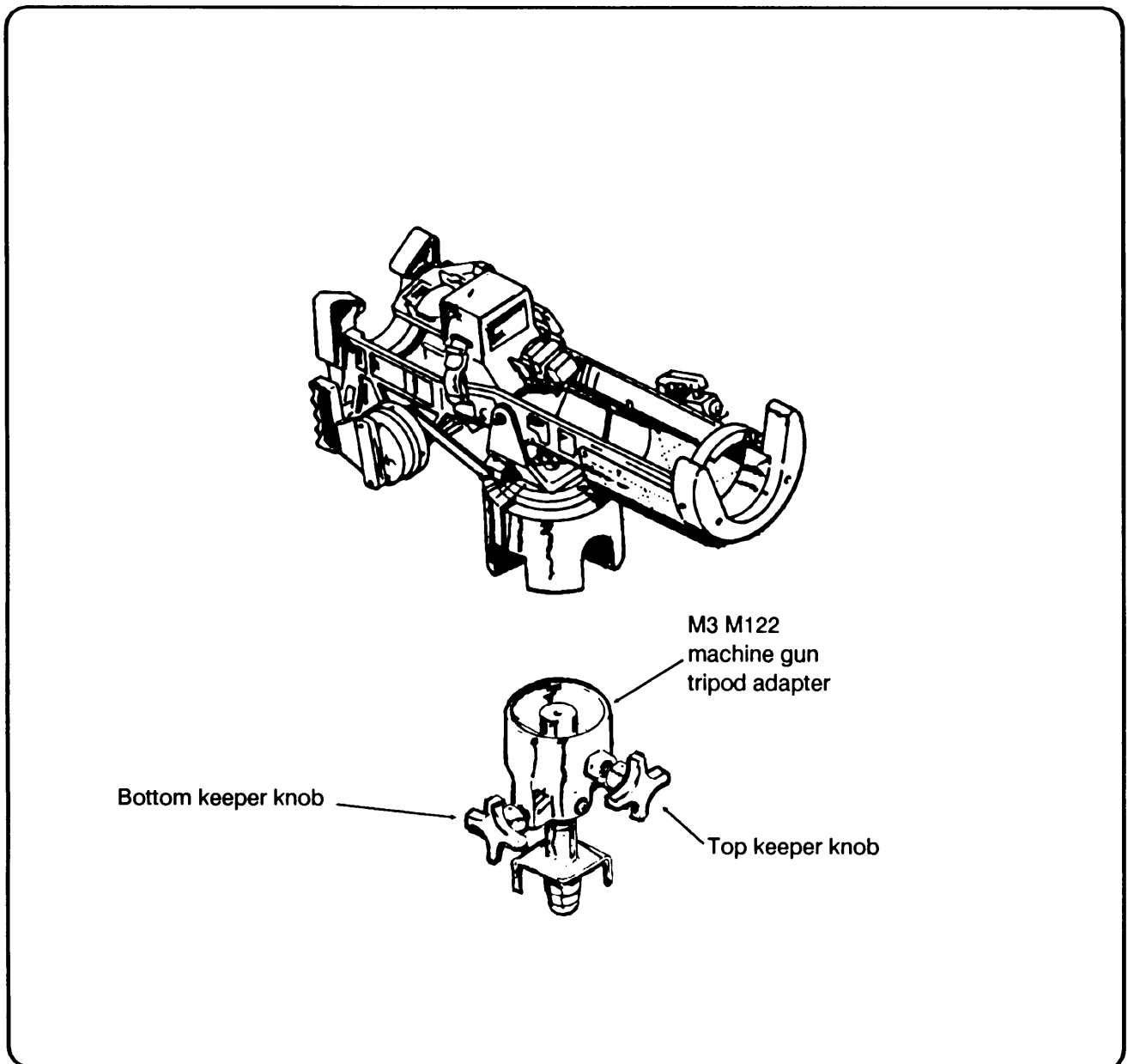

Figure 1-10. Guided missile launcher system, M175.

(2) The mount is used to fire the M222/MK1, MOD 0, tactical rounds or M223 practice round. It accommodates the M54 LET and M57 FHT.

(3) The round and tracker are electrically mated through two

connectors on the mount. They are fired by a remote firing mechanism on the right rear of the cradle.

(4) Azimuth and elevation dampers reduce gunner and vehicle vibrations. They assist the gunner in

obtaining a firm, steady tracking action.

b. M3/M122 Machine Gun Tripods. Either the M3 or M122 machine gun tripods (Figure 1-11) can be used to fire the Dragon from a ground support position.



Sitting-M3 tripod



Sitting-M122 tripod

Figure 1-11. M3/M122 machine gun tripods.

c. **Vehicle Storage Kit.** The kit (Figure 1-12) is installed in all M113 APCs assigned to mechanized infantry squads. It consists of the following night tracker support equipment:

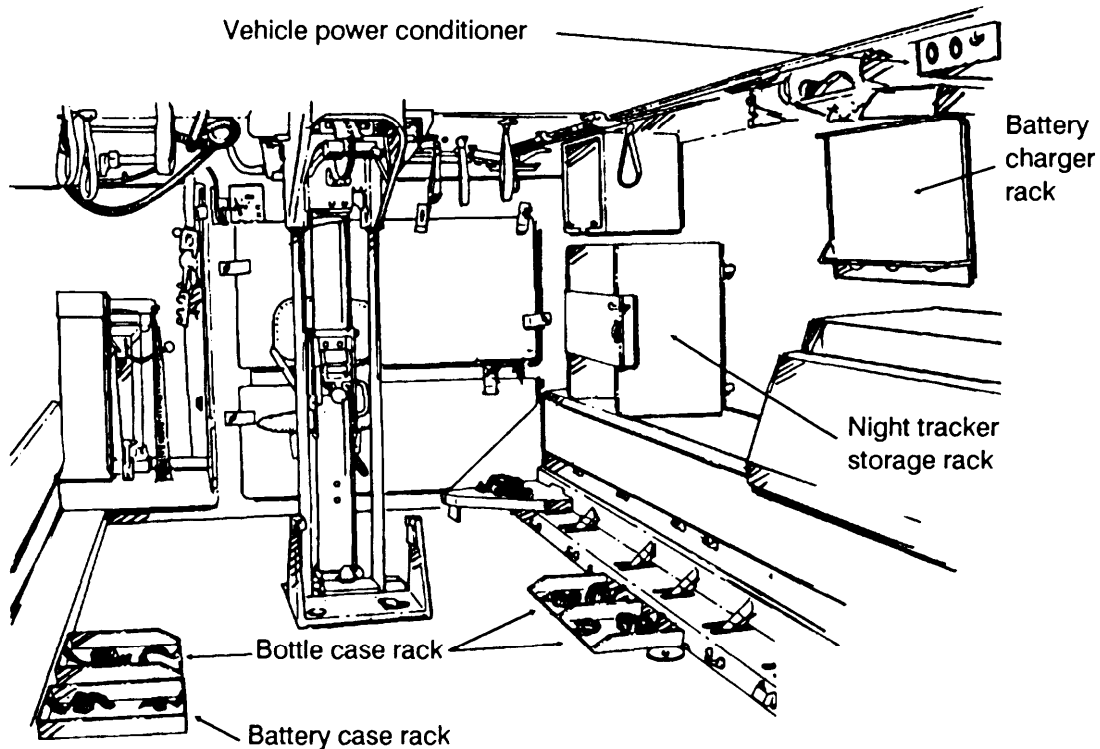

Figure 1-12. Vehicle storage kit.

- (1) A night tracker storage rack, located just below the day tracker storage case, to secure the night tracker when not in use.
- (2) A vehicle power conditioner to step down the power of the 24-volt battery.
- (3) A battery charger rack and a PP-7382/TAS battery charger are

also operated from the APC power source.

- (4) Three coolant cartridge container storage racks and one battery container storage rack are under the personnel seats.

1-4. TRAINING STRATEGY

A training strategy is the overall concept for integrating resources into a program to train individual and collective skills needed to perform a unit's wartime mission. The training strategy for Dragon training is implemented in both TRADOC institutions and also within units. It is composed of four primary components:

- Initial training.
- Sustainment/advanced training.
- Collective training.
- Leader training.

a. Initial gunner training is a prescriptive POI conducted in both institution and unit. It is composed of 15 blocks of instruction and culminates with successful completion of two tracking tables (40 engagements) and the gunner's skill test (10 tasks).

b. Sustainment training ensures retention of skills learned during initial training. This training takes place entirely in the unit: monthly, quarterly and annually. Gunners must have skill retention by practicing precision tracking at least monthly. Gunners fire selected engagements from the monthly sustainment table using LET/LES. They must also complete at least 50 percent of the gunner's skill test hands-on tasks each month,

completing the balance of testing the following month. Each Dragon gunner will verify quarterly the C2 designator by successfully completing the two qualification tables and gunner's skill test. Advanced training is conducted by the unit and consists of field tracking exercises conducted quarterly. Field tracking exercises progress toward more difficult tracking engagements in terms of conditions, equipment, or tactical play. Tracking events include exercises, such as night tracking (under artificial illumination or with the AN/TAS-5 night tracker), tracking with MOPP, or other situational gunnery conditions, using LET/LES or Dragon: MILES. These may be integrated with other Dragon or unit exercises. At the commander's discretion, any combination of these may be scheduled quarterly throughout the year.

c. Each unit is authorized to fire live missiles annually. The number of missiles varies by type unit. The annual live fire may be conducted in an instructional setting or integrated into other unit live-fire exercises. Where possible, live missile firings should closely follow a scheduled qualification, and only currently qualified gunners should be allowed to fire.

d. Collective training takes place in the unit with the goal of fully integrating the Dragon weapon into the unit's overall combat power. It is divided into two parts: force-on-force and live fire.

(1) Force-on-force training is conducted with MILES during squad and platoon FTX/STX. Platoons must be evaluated on Dragon employment during semiannual external evaluations.

(2) Live fire is conducted using the laser target interface device (LTID) or actual missiles (live or inert) in conjunction with platoon live-fire exercises. Dragon gunners/teams must participate in squad/platoon collective live-fire exercises semiannually.

e. Leader training is conducted in both the institution and unit. Leaders are taught to train, maintain, and employ the Dragon in courses such as NCOES and the basic officer's course. This training must continue in units through NCO and officer development classes and personal initiative. The training of Dragon instructors begins with institutional leader training and is fully developed in the unit. Leaders selected as Dragon instructors must be proficient Dragon gunners and be familiar with all aspects of Chapters 6, 7, 8, and Appendix B of this manual.

1-5. UNIT TRAINING PROGRAMS

The ultimate goal of a unit Dragon sustainment program is well-trained gunners so a unit can survive and win on the battlefield. The trainer must realize that qualification is not an end, but a step toward reaching this combat requirement.

a. To reach this goal, the gunner must be able to position and use his weapon under the following combat conditions:

(1) Enemy vehicles are seldom visible except when assaulting.

(2) Most Dragon combat targets can be detected by smoke, flash, dust, noise, or movement.

(3) Some combat targets can be located by using nearby objects as reference points.

(4) The nature of the target and irregularities of terrain and vegetation may require a firer to use a variety of positions in addition to the sitting or standing supported position to fire effectively on the target. In a defensive situation, the

firer usually fires from a standing supported position.

(5) Most combat targets have a low contrast outline and are obscure. Therefore, choosing an aiming point in elevation is difficult.

(6) Time-stressed fire in combat can be divided into three types: a single, fleeing target that must be engaged quickly distributed targets engaged within the time they remain available; and a surprise target that must be engaged at once with accurate fire.

b. The unit's program must provide fundamental training to sustain and improve the skills and proficiency the soldier has attained during his initial training. Once basic skills have been mastered, these must be improved by conducting new or advanced individual and collective training. The program must develop tracking skills by incorporating tracking into tactical exercises. This training must maintain the soldier's confidence in the weapon and his skills. A soldier's survival may

depend on his ability to defend himself or other members of the unit. Therefore, individual and collective tracking skills must support the expected battlefield conditions and the unit's combat mission.

c. A unit's Dragon training program must be battlefield oriented. It must be based upon several individual combat tasks as well as organizational, operational, or contingency missions. It must have available resources such as ammunition, time, ranges, and qualified trainers. This manual provides the information a unit commander needs to develop an effective Dragon training program for his unit requirements.

d. General tracking, training knowledge, and accurate firing are acquired skills that perish easily. Skill practice should be conducted for short periods throughout the year. Most units have a readiness requirement that all Dragon gunners and assistant gunners must have monthly sustainment training with quarterly verification/qualification.

SAFETY

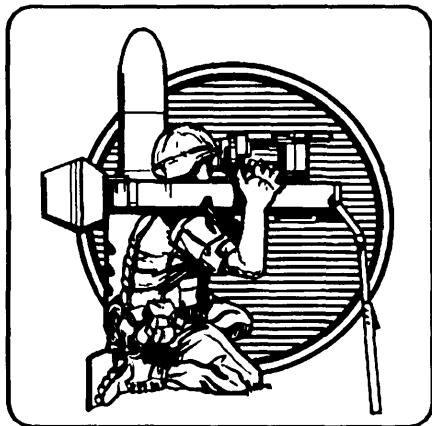

Local directives and SOPs are required to supplement safety precautions. SOPs should include individual responsibilities, safety requirements, distance limits for soldiers and explosives, locations and sequence of operations, equipment needed for handling munitions, and protection of soldiers. Responsibilities for operations involving explosives must be clearly designated. Safety precautions must be observed.

NOTE: Refer to TM 9-1300-206 for detailed ammunition handling and storage safety precautions.

2-1. SAFETY PRECAUTIONS

Other than removing the front shock absorber including the desiccant package, strict observance of safety precautions to prevent personnel from tampering with the encased missile must be enforced.

a. The following precautions must be understood and followed before firing the Dragon:

(1) DO NOT look at the sun, flares, lasers, or searchlights while sighting through the day tracker because telescope magnifies the effect and the eyes could be severely burned.

(2) When firing from the prone firing position, make sure the body is out of the danger area. When tracking moving targets in this position, make

sure the rear end of the launcher does not swing into a position where the backblast could cause injury.

(3) DO NOT fire at targets closer than 65 meters because the warhead will not be armed.

(4) When mating the tracker to the round, use extreme care not to *accidentally fire the round*.

(5) DO NOT allow personnel or equipment forward of the firing position.

(6) DO NOT perform PMCS with the tracker mated to the round.

(7) All personnel within 50 meters of the weapon must wear properly inserted earplugs.

(8) DO NOT fire the Dragon over friendly troops or vehicles.

b. The antireflective coating on the AN/TAS-5 infrared optics contains thorium fluoride that is slightly radioactive. The only potential hazard involves swallowing or inhaling of the coating material. Broken lenses should be disposed of IAW AR 385-11.

c. The Dragon backblast area extends 50 meters to the rear and 30 meters to the flanks of the launcher (Figure 2-1). This area is divided into two zones: a danger zone and a caution zone.

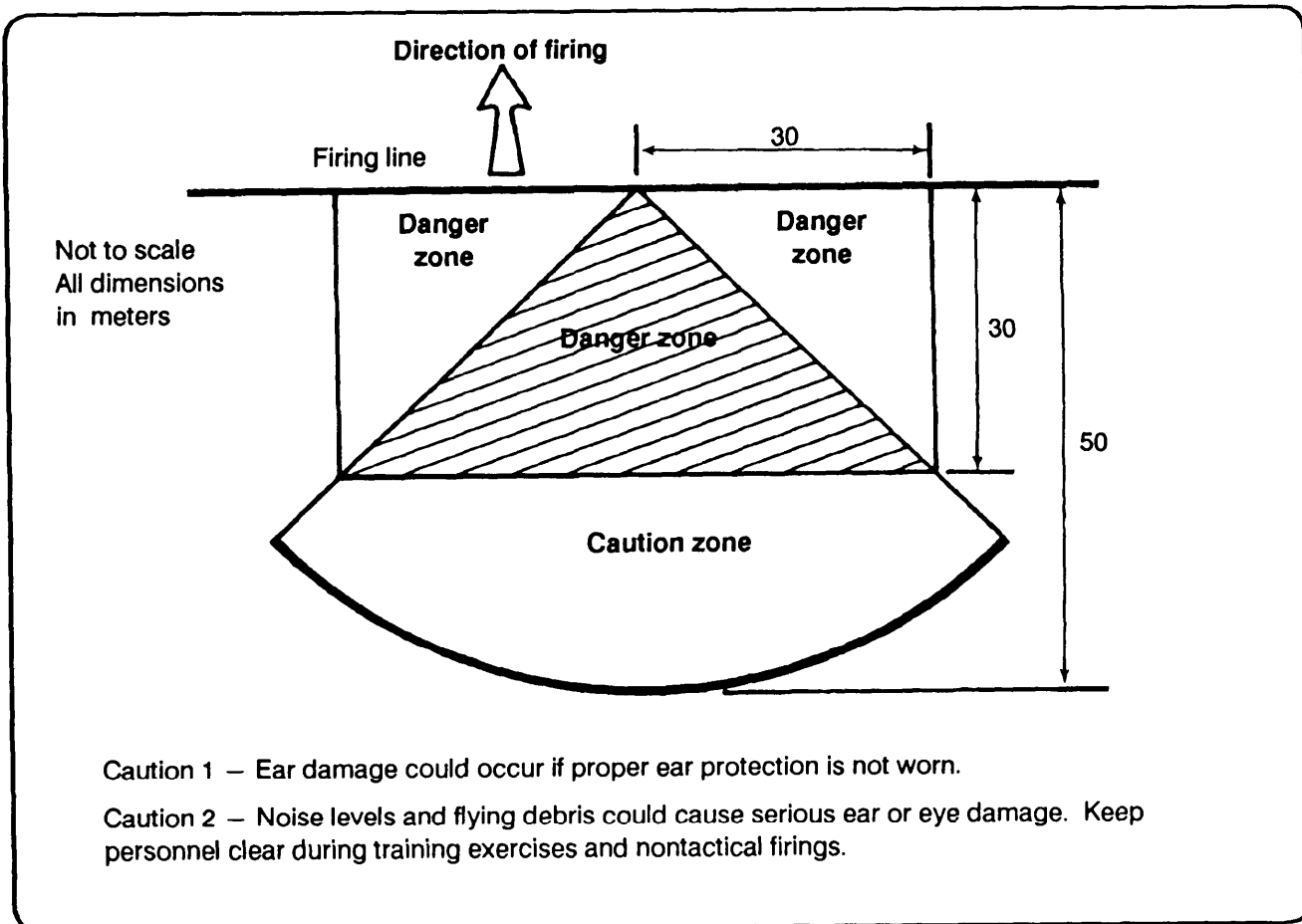

Figure 2-1. Dragon backblast area.

(1) The danger zone extends 30 meters to the rear of the launcher and forms a 90-degree cone. In this area, fatalities or serious casualties could occur because of the blast, flame, and flying debris. Personnel must avoid this zone.

(2) The caution zone extends an additional 20 meters to the rear and 30 meters to the flanks of the danger zone. Personnel should avoid this zone whenever possible. Personnel must wear earplugs and protect their eyes from flying debris by not facing the rear of the Dragon.

NOTE: During training, both the danger and caution zones are kept clear.

d. Because of the danger to soldiers from the backblast of the Dragon, extreme care must be exercised in all phases of instruction. Team drills, position exercises, and tracking exercises must be conducted with the LET and LES as though a tactical missile were being fired.

e. A practice missile can contain live-rocket motors after the end of missile flight. The warhead on this type of missile is inert, but the live-rocket motors present a hazard to personnel. The location of all

practice missiles must be reported to EOD for disposal.

WARNING: When suspended from trees, bushes, or similar objects, the Dragon missile guidance wires present a potential hazard to personnel because of their small diameter and high strength. Access to areas where such conditions can exist should be strictly controlled. When suspended wires are found, they should be removed.

f. During live-fire exercises, safety personnel must stand on either side of the gunner at least 1 meter away. This is due to the expended gases, flame, and debris escaping from the front and rear of the Dragon.

2-2. ROUND HANDLING

Improper or careless handling of the Dragon round can damage the components and cause the missile to malfunction when launched. If there is any reason to believe the missile has been damaged or dropped, or there is evidence of launcher deformation or fracture, the round should be returned to the responsible ammunition personnel for inspection and disposition.

2-3. FIRING LIMITATIONS

The Dragon will not be fired from within buildings, bunkers, or other enclosures or within 50 feet of a vertical or nearly vertical backstop. During training, waivers for this limitation can be granted under the provisions of AR 385-62. During combat, it can become necessary to risk firing the Dragon from enclosures. When this is necessary, the enclosure must be at least 10 feet by 15 feet. Clear all debris and loose objects from behind the launch site. When possible, open all doors, windows, and make holes in the walls and ceilings at least 2 feet by 2 feet to allow the backblast and overpressure to escape. The gunner must wear double hearing protection to reduce the possibility of hearing loss. Some effects of firing a Dragon from a confined space are structural damage, falling debris, concentrated toxic gases, and building fires. All of which can result in injury to the gunner and or team. A Dragon should not be positioned so as to cause the gunner to fire over power lines, through brush or brush fires, or through limbs or other obstructions. They might damage the command-link wire and interfere with the missile guidance.

2-4. FIGHTING POSITION

When firing from a fighting position, there should not be any obstruction to the front or to the rear of the launcher to deflect the backblast toward the gunner. Special care must be taken when firing from a downhill or uphill slope to ensure that the angle of the launcher relative to the ground is *not greater than* 20 degrees. In either a hasty or prepared fighting position, there must be a minimum clearance of 6 inches above and below the muzzle of the launcher. This clearance allows the missile fins to fold out and lock into place.

2-5. FIRING OVER WATER

When firing the Dragon over salt water, the distance should not exceed 300 meters. Salt water can short out the command-link wire. Raising the launcher 1 foot increases the distance it can fire overwater by 100 meters. When firing over fresh water, there is no effect on the command-link wire so the missile can be fired to the maximum range.

2-6. TRAINING EQUIPMENT

Safety precautions must be observed at all times. During training, the soldiers must practice and observe the same backblast area precautions for the LET/LES as they would for live fire (paragraph 2-1) (Figure 2-1). The training equipment generates sound and pressure levels that can damage hearing. Hearing protection must be worn at all times by personnel on or about the firing area.

a. **Launch Effects Trainer.** The following safety precautions for the LET must be observed at all times:

WARNING: If a misfire occurs in which the primer explodes but fails to ignite the powder, clean the pressure chamber before the LET is reused. When misfires (more than 5 percent) occur that are not due to a malfunctioning firing mechanism, notify the ammunition supply point as soon as possible.

(1) *Misfire.* If a misfire occurs, the gunner maintains the LET in the firing position for 60 seconds. After the 60 seconds, the loader unloads the M64 cartridge.

WARNING: Do not load the LET for alignment procedures.

WARNING: Gunners are limited to five LES shots in a 24-hour period in accordance with the surgeon general's guidelines on preventing hearing losses.

(2) *Sound levels.* The sound levels are common to both the LET and the LES systems. Sound and pressure levels can damage hearing. Ear protection must be worn by all personnel in the area when either the LET or the LES is fired.

(3) *Backblast area.* The M64 grenade launching cartridge has a backblast area that extends 3 meters to the rear of the LET and forms a 90-degree danger zone. During training the gunner should practice and observe the same backblast area as that of the Dragon (50 meters).

b. **Launch Environment Simulator.** Damage to the LES's circuits because of static discharge can allow the LES to fire when the arming switch is moved into the arm position. When preparing to conduct a LES training session, the backblast area must be cleared during the system checkout procedures.

(1) *Flammables.* The LES uses flammable and explosive gases under pressure. Smoking or open flames are not allowed within 50 meters of an operating LES or storage area.

(2) *Oil contamination.* Oil and or petroleum products ignite explosively when exposed to pure oxygen. Oily contaminants must be removed from the area around the LES.

WARNING: Exercise extreme caution when using the LES. Wear gloves when placing end caps on the front and rear of the system to avoid being burned by accidental firing.

(3) *Premature firing.* Damage to the LES's circuits because of static discharge can cause the LES to prematurely fire. Leather gloves must be worn when placing the end caps on the front and rear of the LES. When preparing to conduct LES training, ensure that the backblast area remains clear during the LES system checkout procedures.

(4) *Misfire procedures.* If a NO FIRE occurs (the gases fail to ignite), perform the following procedures:

(a) Wait five seconds and squeeze the firing mechanism again.

(b) If the LES still does not fire, the instructor immediately sets the SAFE-ARM switch on the control box to SAFE. Then, he sets the PWR ON-OFF-CHARGE switch to OFF.

(c) Do not allow any part of the body - to extend in front of or behind the LES launcher while performing the following steps:

- Remove both end caps from the launcher and allow a minimum of two minutes for the gases to vent.
- Unlatch and reseal the tracker.
- Reinstall both end caps after a two-minute vent (step 4).
- Set PWR-ON-CHARGE switch to ON.

(d) If the BATTERY TEST indicator does not illuminate, perform BATTERY and GLOW PLUG tests. If GLOW PLUG circuit test does not illuminate, set

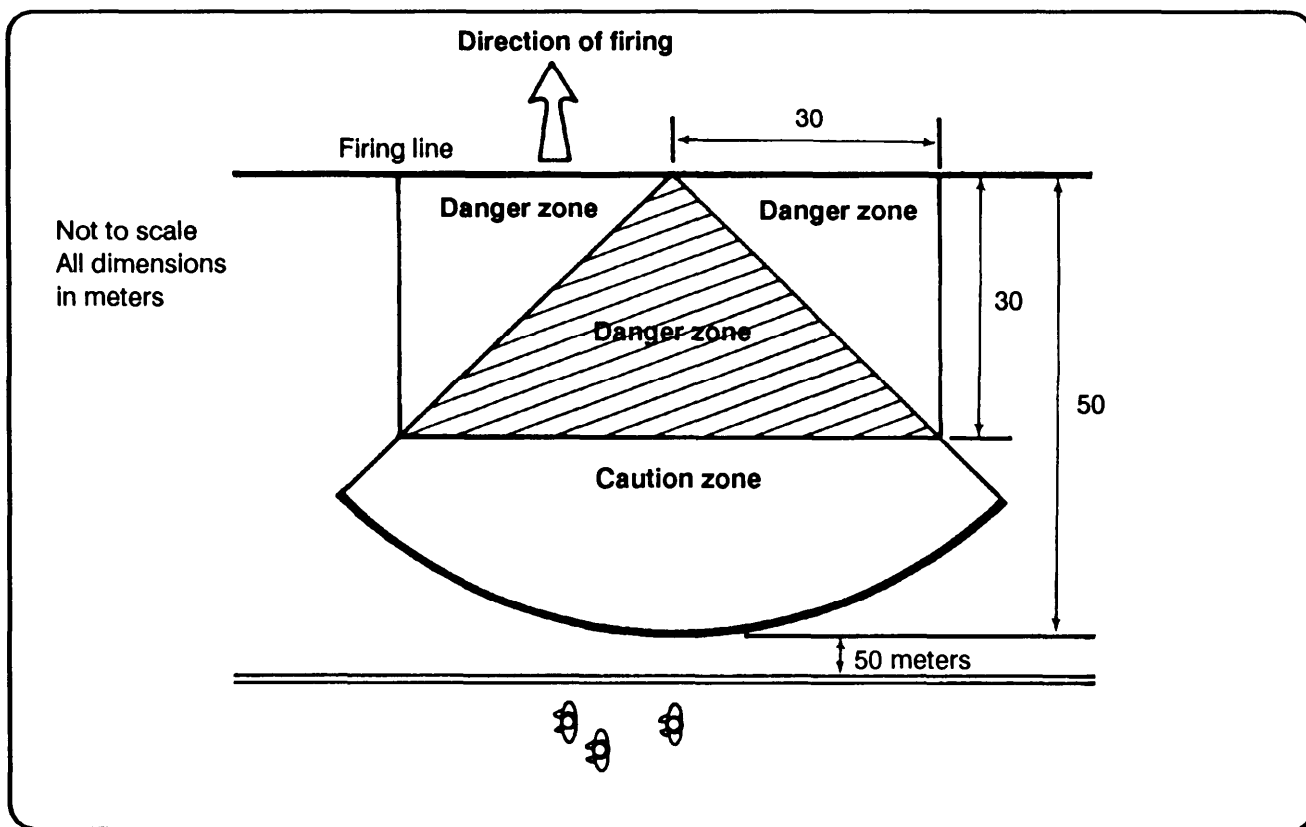

Figure 2-2. Personnel crossing 50 meters behind LES.

GLOW PLUG SELECT switch to alternate circuit and retest.

(e) Check the oxygen pressure and MAPP gas level.

(f) Depress FILL pushbutton and release.

(g) If immediate-action procedures do not correct the misfire, return the LES to TSC for maintenance.

(5) Debris. Personnel must not stand in front of or in back of the LES when it is being freed. If it is necessary to cross behind the LES, they must cross at least 50 meters away (see Figure 2-2).

c. **Dragon/MILES.** Always wear earplugs when firing the Dragon/MILES.

(1) *Laser light.* Although the laser light emitted by MILES is eye-safe in ordinary use, precautions should be taken to lessen the chance of eye injury from excessively close or repeated exposures. Precautionary measures include the following

- Avoid viewing the laser emitter at close range (less than 12 meters). Increase the distance from the eye to the laser source to reduce the risk of over-exposure.
- Avoid viewing the emitter directly along the optical axis of the radiated beam.
- Avoid viewing the emitter directly along the axis of the beam through stabilized optics, such as binoculars, telescopes,

or periscopes, at ranges of less than 75 meters.

(2) *ATWESS cartridge.* Handle the Dragon/MILES like any loaded and armed weapon. Do not drop the Dragon when an ATWESS cartridge is loaded and armed. A *strong* jolt may cause it to fire. Never arm an ATWESS until ready to fire. Never load an ATWESS with the arming lever up. Never stand behind the weapon when loading the cartridge. Handle ATWESS cartridges with the same care as with any live ammunition.

(3) *Other safety precautions.* Always observe the cautions and warnings for the Dragon while operating or performing maintenance on the LES.

EMPLOYMENT OF THE DRAGON

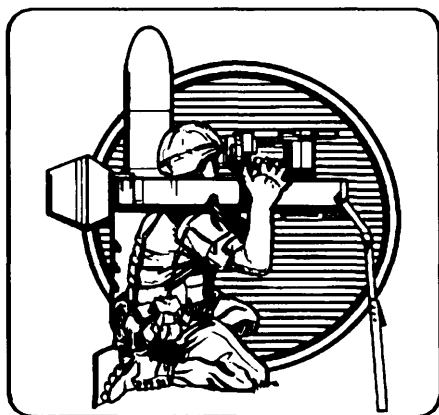

This chapter discusses considerations for and techniques of employment for the Dragon during offensive, defensive, and retrograde operations. This chapter is keyed to the Dragon as an infantry weapon; however, the infantry techniques discussed apply to any situation for all types of units. Specific areas of discussion include selection and preparation of firing positions, target engagement techniques, and fire control procedures. To fully understand and properly integrate the Dragon into tactics and techniques, leaders must be familiar with FM 7-7, FM 7-7J, FM 7-8, or FM 7-10, whichever applies.

Section I. DRAGON ROLE AND PERSONNEL DUTIES

The Dragon's role, location within the organization, and personnel duties are discussed in this section.

3-1. DRAGON ROLE

The Dragon's primary role is to destroy enemy armored vehicles. When there is no armored vehicle, the Dragons can be employed in a

secondary role of providing fire support against point targets such as bunkers and crew-served weapons positions. Combat and CS units

normally use the Dragon in a self-defense role during rear operations.

3-2. ORGANIZATION WITHIN ANTIARMOR SECTION

In the nonmechanized and nonairborne infantry organizations,

Dragons are in the antiarmor section of the headquarters platoon of each

rifle company. (See Figure 3-1.) The antiarmor section has 13 personnel

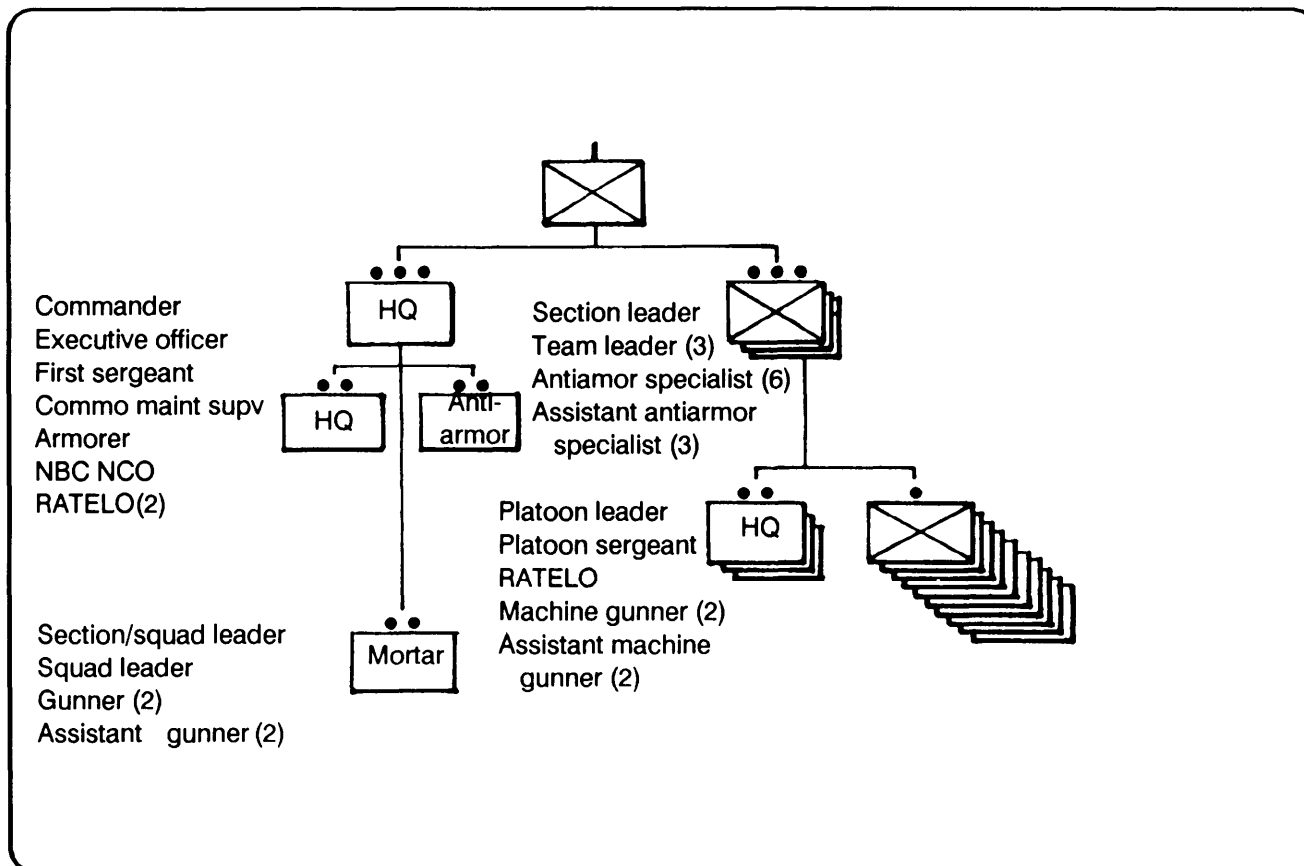

Figure 3-1. Nonmechanized and nonairborne infantry rifle company organization.

and six medium antitank weapons. It is organized into three teams of four men with two medium antitank weapons each. The section leader is a SSG and each team is led by a SGT. The section provides medium-range antiarmor support to the company. It can be employed under company control or as separate teams attached to platoons. When no armored threat exists, the antiarmor section fights as infantry under the control of the company commander or attached to one of the platoons. It can be employed as a fourth maneuver element, or as a reconnaissance element.

NOTE: Airborne, air assault, motorized, and ranger-type organizations are basically

organized the same as nonmechanized and nonairborne infantry organizations. (See FM 7-8.) The discussion in this paragraph is keyed to the nonmechanized and nonairborne infantry antiarmor sections. However, the principles also apply to the units with similar-type organizations.

a. Antiarmor Section. The antiarmor section can be positioned in several ways, depending on the tactical situation, armor avenues of approach, and assigned mission.

(1) If they are used in the antiarmor role, they may be attached in part or whole to platoons. This is because they have more equipment than is

feasible for them to carry, and the platoon can assist them. Also, by spreading the antiarmor weapons throughout the company, the commander ensures that each element has increased antiarmor capacity.

(2) As an alternative, the antiarmor section can overwatch the company's movement as a separate element. This method is easiest if the movement is short and good overwatch positions are available near the LD; some difficulties exist with this method. The section leader must rely on PRC-68s, with limited range and reliability, to control his teams. Also, the day and night tracker and multiple rounds of Dragon ammunition are hard to

carry. These problems are partly solved by choosing overwatch positions near the LD, and then choosing new ones by map reconnaissance. These must be confirmed as the company moves past them.

(3) The first teams emplaced join the rear of the company formation when it passes a predetermined point. This bounding method provides limited security for the antiarmor teams during movement and emplacement and ensures continuous antiarmor support for the company during movement. However, the Dragon equipment's weight will hinder their movement.

(4) The commander can consider forming armor-killer teams by task-organizing a Dragon team and a fire team or squad. These teams overwatch the company's movement under control of the antiarmor section leader. This gives the antiarmor section both load-carrying capacity and local security, although it decreases a rifle platoon's strength.

(5) When antiarmor section personnel are acting as riflemen, they may travel separately or as an element in the company formation. They may be in reserve, serve as a reconnaissance element, be attached to a platoon to form a fourth squad, or combined with the mortars to provide local security and to help carry ammunition. In this case, a leader, such as the XO, should lead. When serving as riflemen, it is not recommended that the antiarmor section be attached by teams to the platoons because this has a piecemeal effect. It also does not use the leadership ability or

communications assets of the section leader.

b. Command and Support Relationships. The antiarmor section normally operates under control of the company commander. This allows the commander to effectively mass the effects of Dragon antiarmor fire by giving mission-type orders to his antiarmor section leader. However, the commander can choose to task-organize in a variety of ways.

(1) Having part or all of the section attached to an element, led by the ISG or XO, aids greater supervision, control, and coordination of the section. The commander is then free to command. Examples might be a support or overwatch element consisting of the antiarmor and mortar sections, a DLIC in a withdrawal, or an antiarmor ambush led by the XO or ISG.

(2) Having part or all of the section attached to a platoon(s) adds combat power to the platoon. It also allows platoon members to assist the antiarmor section to carry their weapons and equipment and gives the antiarmor section local security. When the antiarmor teams are spread out among the platoons, it ensures that each platoon has some antiarmor capability. This may be necessary for movements (both for cross-loading and load-carrying purposes) and for providing supervision and control to the antiarmor section, especially during infiltrations. Examples are a platoon antiarmor ambush, a platoon as the DLIC in a withdrawal, and a platoon tasked to provide antiarmor fire into an engagement area.

(3) Having a part(s) of the section attached to a squad(s) forms either a

squad-size antiarmor ambush or squad-size or fire team-size armor-killer teams. These teams may operate independently within the company and platoon operations, or as part of a larger element (several armor-killer teams as part of an antiarmor ambush).

c. Mechanized/BFV Organizations. In mechanized and BFV organizations, Dragons are assigned to the rifle platoons in each rifle company and to the scout section in headquarters company. Normally, a rifleman in each squad is designated and trained as a Dragon gunner.

(1) The Dragon gunner carries the tracker and one round. The Dragon rounds and the frequent need for them may make it necessary to form a Dragon team when the squad dismounts the carrier. Such a team consists of the gunner, with a tracker and one round, and one or more additional riflemen to carry rounds and the night tracker, if available, to assist in target acquisition. This provides a measure of local security.

(2) Dragon teams, if formed, are combined into the squad or platoon organizations for command, control, and security. Units should cross train as many squad members as possible on the Dragon in case the gunner becomes a casualty.

d. Command and Control. Since the Dragon is one of the principal armor-defeating weapons in the platoon, its use is governed by the platoon leader's assessment of the tactical situation. The platoon leader has three control options:

(1) *Centralized control (heavy units only)*. The major advantage of centralized control is the platoon leader's positive control of one of his

primary armor-defeating weapons. This gives the platoon leader the flexibility to quickly mass the fires of the Dragons to meet a changing threat. Its major limitation is that the platoon leader, during contact with the enemy, must be able to communicate with the Dragon gunners and teams, either directly or indirectly, and control their fires in all situations besides his other duties.

(2) *Decentralized control.* The major advantage of this method of control is all-round antiarmor protection for the platoon and a relatively quicker response time for individual target engagements. Its major limitation is the lack of positive control by the platoon leader, resulting in his

inability to quickly mass Dragon fires when and where needed. It also burdens the squad(s) with tracker and rounds that are not needed for all situations, yet must be carried at all times. This results in a dissipation of the squad's other capabilities.

(3) *Combination of control.* To quickly influence an action, the platoon leader should normally keep at least one Dragon under his control. In effect, he is employing a combination of centralized and decentralized control. When properly applied, this method combines the advantages of centralized and decentralized control and lessens their limitations. Regardless of the form of control

used, the overall responsibility for the proper employment of the Dragon rests with the platoon leader. The platoon leader should ensure that as many members of the platoon as possible are cross trained on the Dragon system. They must maintain a high degree of proficiency, establish command and control procedures (SOPs, communications, and so forth), and conduct unit training with the Dragon. Once in combat, the platoon leader decides when and where to employ Dragons, how many should be used, and the method of control. He must also supervise all aspects of Dragon employment and remain abreast of the tactical situation to react accordingly.

3-3. PERSONNEL DUTIES

Individual tasks that must be performed to successfully employ the Dragon in the defense are in

Table 3-1. Although some tasks are listed for one or more leaders, the

tasks differ in scope and degree of proficiency.

TASKS TO BE PERFORMED	PLT LDR OR PLT SGT	MECH/ CBT SPT	ANTIARMOR SECTION		GUNNER/ ASST GNR
		SQD LDR	SEC SGT	TM LDR	
Integrate Dragons into the platoon/ company tactical plan	X		X		
• Select general weapons positions	X		X		
• Assign sectors of fires	X		X		
• Coordinate mutual support	X		X		
• Coordinate with adjacent units					
Reconnoiter for, and select, tentative Dragon firing positions (primary, alternate, and supplementary) and routes between positions	X		X		

Table 3-1. Task responsibilities.

TASKS TO BE PERFORMED	PLT LDR OR PLT SGT	MECH/ CBT SPT	ANTIARMOR SECTION		GUNNER/ ASST GNR
		SQD LDR	SEC SGT	TM LDR	
Supervise continual preparation of positions		X	X	X	
Coordinate security for Dragons	X	X	X		
Inspect the selection of tentative firing positions, confirm or make adjustments		X	X	X	
Supervise preparation of range card		X	X	X	
Control movement of gunners between positions		X	X	X	
Issue fire commands to gunners	X	X	X	X	
Coordinate resupply and collection of extra rounds carried in platoon	X	X	X		
Identify enemy avenues of approach	X	X	X		
Prepare fighting position (primary, alternate, supplementary)				X	X
Prepare range card					X
Designate target reference points	X	X	X		
Prestock Dragon rounds				X	X
Prepare round for firing					X
React to fire commands					X
Engage targets					X
Prepare M113 for Dragon firing					X
Prepare Dragon for firing on M3/M122 tripods					X

Table 3-1. Task responsibilities (continued).

a. Antiarmor Section Leader (Nonmechanized and Nonairborne Infantry). The antiarmor section leader is responsible for the overall performance of the section. He is both a planner and a leader, and must be prepared to execute the following tasks with his section:

(1) Becomes the principal advisor to the commander on employment of

all organic and attached antiarmor assets.

(2) Provides antiarmor support to the company during defensive and offensive operations, to include preparing an overall plan, reconnoitering tentative Dragon firing positions, and controlling antiarmor fires.

(3) Plans and leads reconnaissance, security, and combat patrol

operations, either as the leader of a single element or using the separate antiarmor sections in coordinated actions.

(4) Participates in or leads the company reserve or CP security element.

b. Squad Leader/Team Leader. The squad leader of an infantry rifle squad or team leader of an antiarmor section (operating

independently of the section) is in command of the team and is responsible for –

- Observing adjusting controlling, and supervising the conduct of fire of the Dragon.

Ž Employing the Dragon according to the platoon leader’s orders.

- Informing the platoon leader of

- Supervising resupply.

c. Gunner. The gunner acquires the target, and determines if it is within range, to track and fire on designated targets. He maintains the weapon. The gunner carries the tracker in the carrying case and one round.

d. Assistant Gunner. The assistant gunner prepares a second round for firing if the need arises and assists in construction of the fighting position. He ensures the backblast area is clear before firing and assists the gunner in maintenance of the Dragon. He carries one round and the night tracker (if available).

NOTE: The team leader in an antiarmor section also performs duties as assistant gunner.

Section II. EMPLOYMENT OF DRAGON IN THE DEFENSE

This section provides guidance for the platoon leader, the section/squad leader, and the Dragon gunner and team in

employing the Dragon in defensive operations. These provisions apply to the rifle platoons of all types of infantry battalions and

sections/platoons of other types of units.

3-4. CONSIDERATIONS

The guidelines herein are for use as a foundation for specific tactics or techniques. Before employing the Dragon, the number of trackers and rounds must be determined for carrying and proper positioning and how to protect them before, during, and after firing. When operating in an armor environment, carry two trackers (day and night) to maintain antiarmor capabilities should one tracker be destroyed or become inoperative. To determine the round distribution (that is, which portion of the unit’s basic load is carried with the platoon), the company commander (light) or the platoon leader (mechanized or BFV) considers the following variables that impact on his decision:

- Mission. Are we attacking, defending, or conducting a

retrograde operation? Are we mounted or dismounted?

Ž Enemy. Large numbers of enemy armored vehicles in the vicinity may mean the need for all Dragon rounds.

- Terrain. Suitable fields of fire and trafficable terrain increase the likelihood of engaging enemy armor with Dragons at long ranges, possibly allowing more than one shot for each gunner.

- Troops Available. The capability to carry extra rounds (dismounted) is directly in proportion to soldier strength; that is, the larger the platoon, the more soldiers are available to carry rounds.

- Antiarmor Fire Support Available. When other forms of antiarmor fires (TOW, tanks, attack helicopters) are available, Dragons may assume a secondary role. This decreases the need for a large number of rounds, especially during dismounted movements.

Target engagement during darkness, haze, smoke, or fog is limited. The platoon/company must have a simple and quick procedure or SOP that aids quick engagements and includes provisions for –

- a. Target Acquisition. Target acquisition can be initiated by the gunner using his tracker, RSTA devices, designated individuals using binoculars or NVDs, or a combination of these devices.

b. Communications. The platoon leader ensures that communications exist for the rapid issue of target acquisition data, illumination requests, and fire commands. SOPs, signals, and fire commands are essential. When in a static position, one method is to “hot loop” all

essential personnel on wire communications.

c. Illumination. If natural or battlefield light sources (for example, burning vehicles) is insufficient for target illumination, the gunner uses the AN/TAS-5 tracker to engage targets without illumination. Responsive artificial

sources of illumination may be available and dedicated to support antiarmor fires. Artillery and mortar illumination are examples of illumination available to platoon leaders. (AN/TAS-5 operational capabilities are discussed in Chapter 1.)

3-5. DEFENSIVE OPERATIONS

In infantry units, the platoon’s mission in the defense is to repel the enemy’s assault by fire and close combat. The Dragon has combat characteristics that are of major

importance in the defense. Control of Dragon fires may be centralized, decentralized, or a combination of these methods. Dragon(s) can –

- Destroy or immobilize armored vehicles, depending on type.
- Deliver accurate fire, day or night.

3-6. FIRING POSITIONS

The Dragon is employed to provide antiarmor protection for the platoon area and as part of the coordinated company antiarmor defense plan. The platoon leader selects the

general firing position and a sector of fire for each Dragon.

a. When choosing a firing position for the Dragon, certain basic considerations must be observed to

increase its effectiveness. These considerations apply to the selection of primary, alternate, and supplementary positions. (See Figure 3-2.)

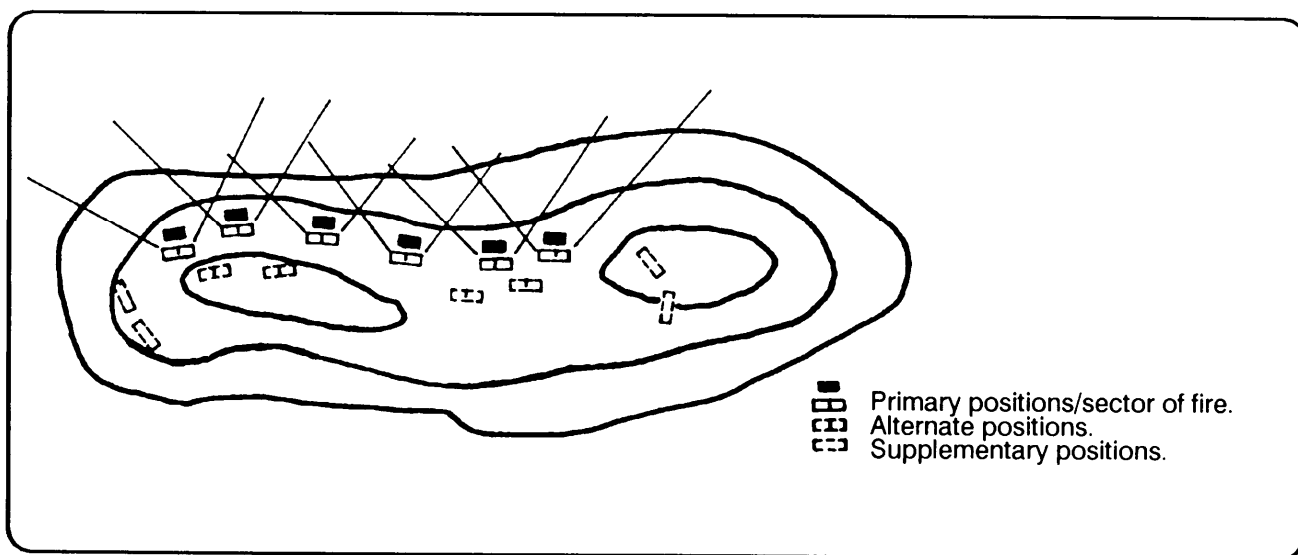

Figure 3-2. Primary, alternate, and supplementary positions.

(1) The **primary position** is one from which a gunner or team can cover its sector of fire. It should have observation, cover and concealment, and a good field of free.

(2) The **alternate position** is to a flank or slightly to the rear of the primary position. The gunner or team must be able to cover the same sector of fire from the primary position. It is occupied when the primary position can no longer be occupied.

(3) The **supplementary position** covers avenues of approach and any remaining TRPs other than those

covered by the primary and alternate positions. It is usually close enough to the primary position to have mutual support with other positions.

b. The Dragon gunner may have to displace often from firing position to firing position in the attack and retrograde and from primary to alternate and supplementary positions in the defense. Whether mounted or dismounted, certain basics apply when moving into and out of firing positions.

(1) Move into the positions from the rear. In the defense, only movement forward of the position should be the

gunner and other individuals clearing fields of fire. The leader checks for cover and concealment, and paces distances for the range card.

(2) Select good covered and concealed routes. Gullies and reverse slopes offer excellent routes to move in and out of position. These aid in movement and protection.

(3) Refrain from disturbing natural foliage.

(4) Keep movement in and around the position to a minimum.

3-7. DRAGON POSITIONING

The main factors when positioning the Dragon for employment are two-fold: gunner protection and the best use of weapon capabilities. The gunner must remain exposed while tracking his targets since he is susceptible to counterfires for as long as 12 seconds if engaging at maximum range. (See Figure 3-3.)

NOTE: Avoid selecting a position that would cause or require the gunner to fire into the sun, which could affect his ability to track the target.

a. Many of the steps for protecting gunners also optimize their fires.

b. Mission accomplishment can be enhanced by some basic rules when selecting positions:

(1) Use natural cover and concealment. Use the terrain for cover from enemy fire and for concealment from enemy ground and aerial observation. (See Figure 3-4.)

(2) Engage the enemy with flank or rear shots from behind frontal cover whenever possible. (See Figure 3-5.) It is extremely difficult for the enemy to retrace the flight path of a round to its launch site and to reorient his weapons to the firing position when the round moves obliquely across his front, as opposed to being launched from a head-on position. When firing to the oblique, the gunner is protected from enemy fire to his front by constructing a parapet or using natural cover that adds to the enemy's problems in detecting the launch signature. Gunners must never be positioned where they must engage a frontal target.

(3) Avoid positioning gunners so that they must engage targets, mainly tanks, from the front. The missile will probably not defeat a tank hit in the frontal 60-degree arc. Other targets (APCs, CFVs) are also easier to kill from the flanks and rear.

(4) Employ Dragons so they are mutually supporting to provide some

degree of protection for the Dragon gunner by ensuring continuous coverage of enemy armor vehicles. It consists of two parts:

(a) Employ Dragons so that their fires interlock with and support other Dragons, TOWs, or tanks. Ensure that sectors of fire overlap and cover the sector by more than one antiarmor weapon.

(b) Position Dragons so they can engage enemy armored vehicles that are assaulting another Dragon, TOW, or tank position.

c. Dragon gunners must integrate with nearby infantry for security. If the Dragon is employed away from the squad or platoon, provisions should be made to provide the Dragon gunners with local security. Such security includes forming a Dragon team and an armor-killer team (FM 7-8).

d. The enemy should be engaged within the gunner's and weapon's capabilities. Dragon gunners should

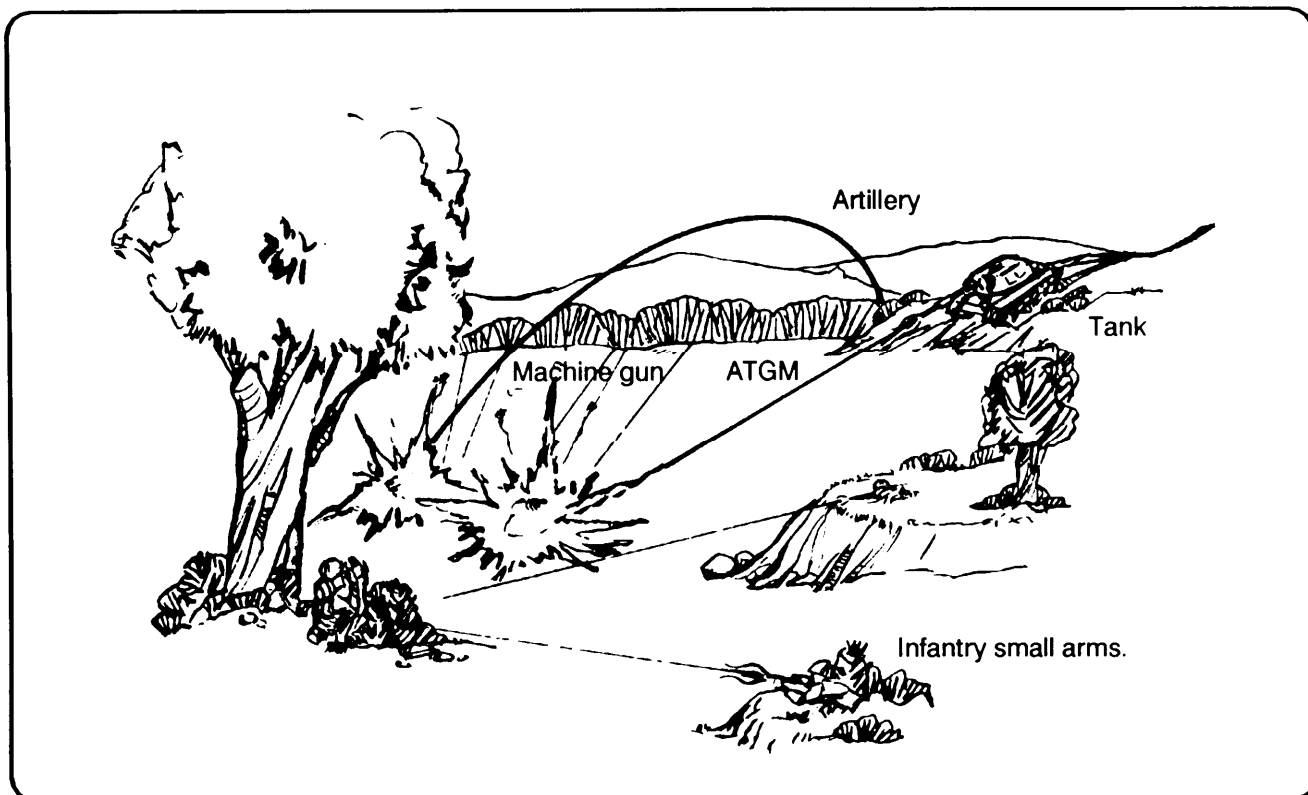

Figure 3-3. Dragon positioning considerations.

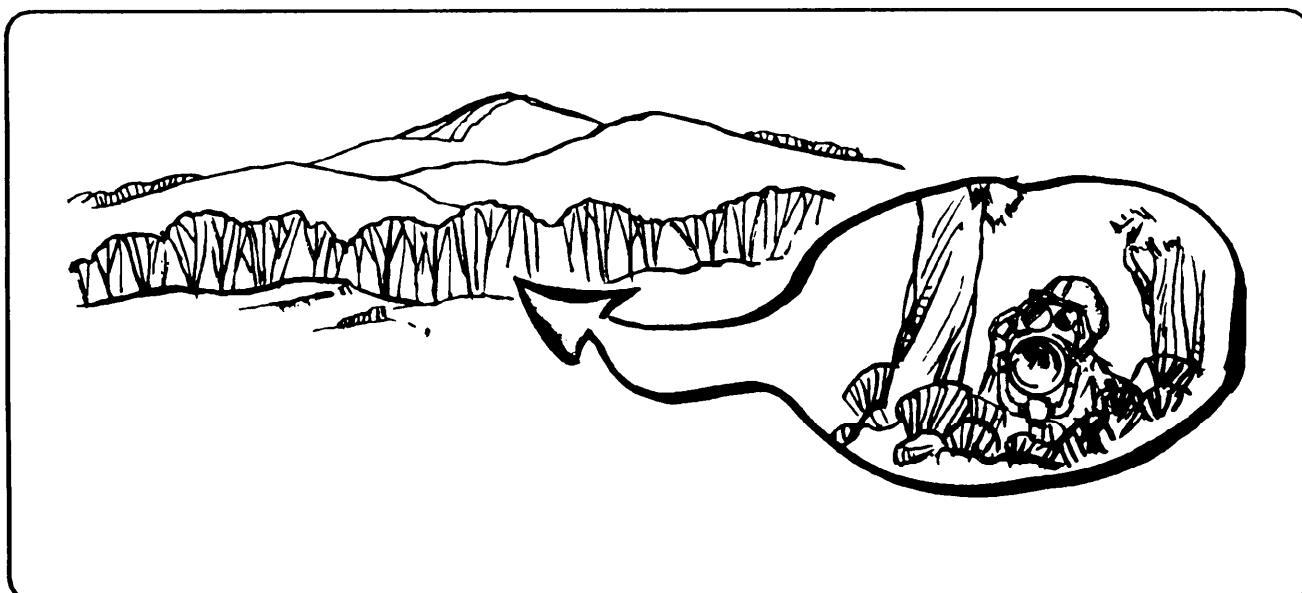

Figure 3-4. Use of natural cover and concealment.

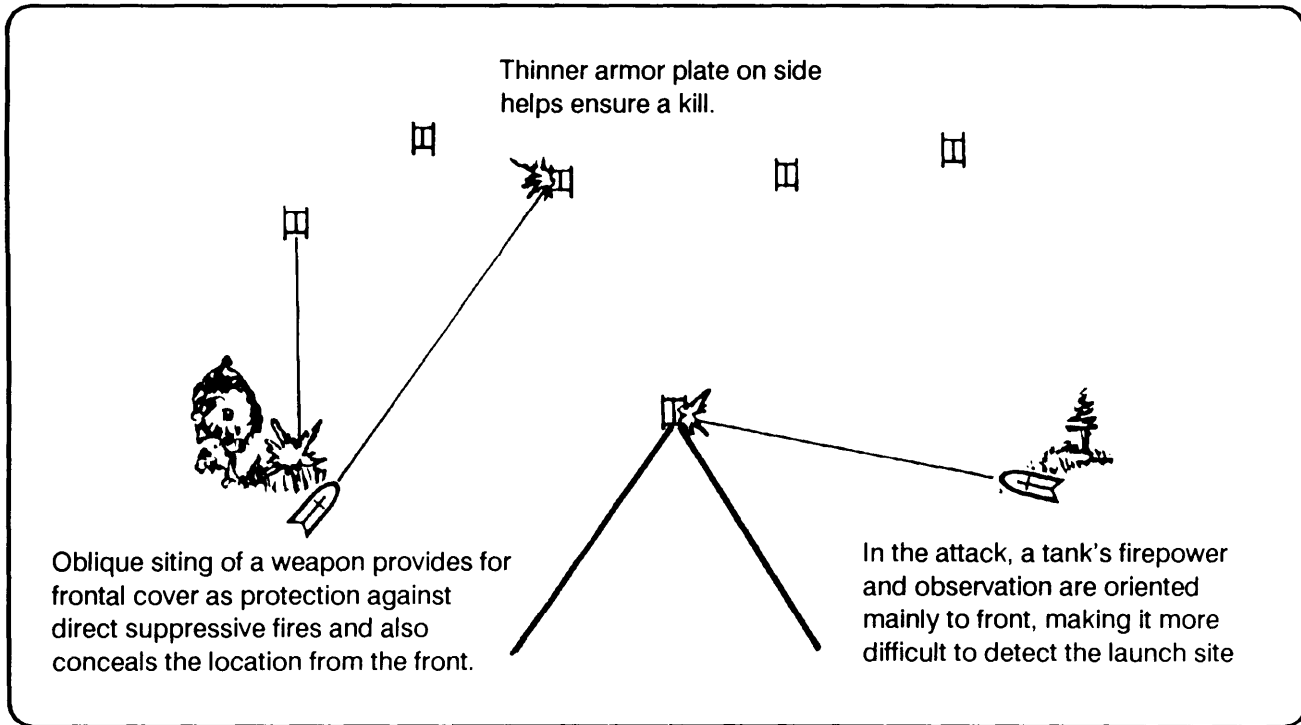

Figure 3-5. Engagement of the enemy with flank or rear shots.

be instructed *not to engage targets* immediately when a target comes within range (1,000 meters). Targets at this range appear to be about the size of a postage stamp in the gunner's sights. He will have more difficulty if he is engaging with the night tracker because of the thermal image. The *Dragon's best engagement range* against moving targets is from 200 to 800 meters. First, the gunner will probably not use all of the rocket motors (thrusters) within these ranges; second, his vulnerability to

enemy count erfire is reduced because of the shorter flight time; third, the target will be larger in the sights. The level of proficiency of the gunner reflects in his ability to track and hit the target.

e. Deception must be used to confuse the enemy as to the true location of the Dragon. The enemy is prevented from detecting the Dragon launch signature (backblast) by clearing away loose debris behind the launcher, wetting down the

backblast, and covering the ground with shelter halves. Movement is reduced in and around the position to prevent detection. Indirect fires (HE, smoke, and WP) and small-arms weapons are used to distract the enemy as long as the target is not obscured. Other deception measures include preparing partly visible dummy positions to draw enemy fire away from the actual positions and positioning Dragons on less obvious or prominent firing positions.

3-8. POSITIONING CONSIDERATIONS

During reduced visibility (darkness, fog, smoke, rain, snow, sandstorms), the Dragon is repositioned closer to armor avenues of approach. (See Figure 3-6.) This compensates for

the reduced range of the Dragon if it is not equipped with the AN/TAS-5. Armor avenues of approach can change at night. To maintain control and orientation at night, armor units must use roads or

open terrain. A lightly wooded area that is not an obstacle to daylight movement becomes an obstacle at night. When repositioning the Dragon, security is still a requirement.

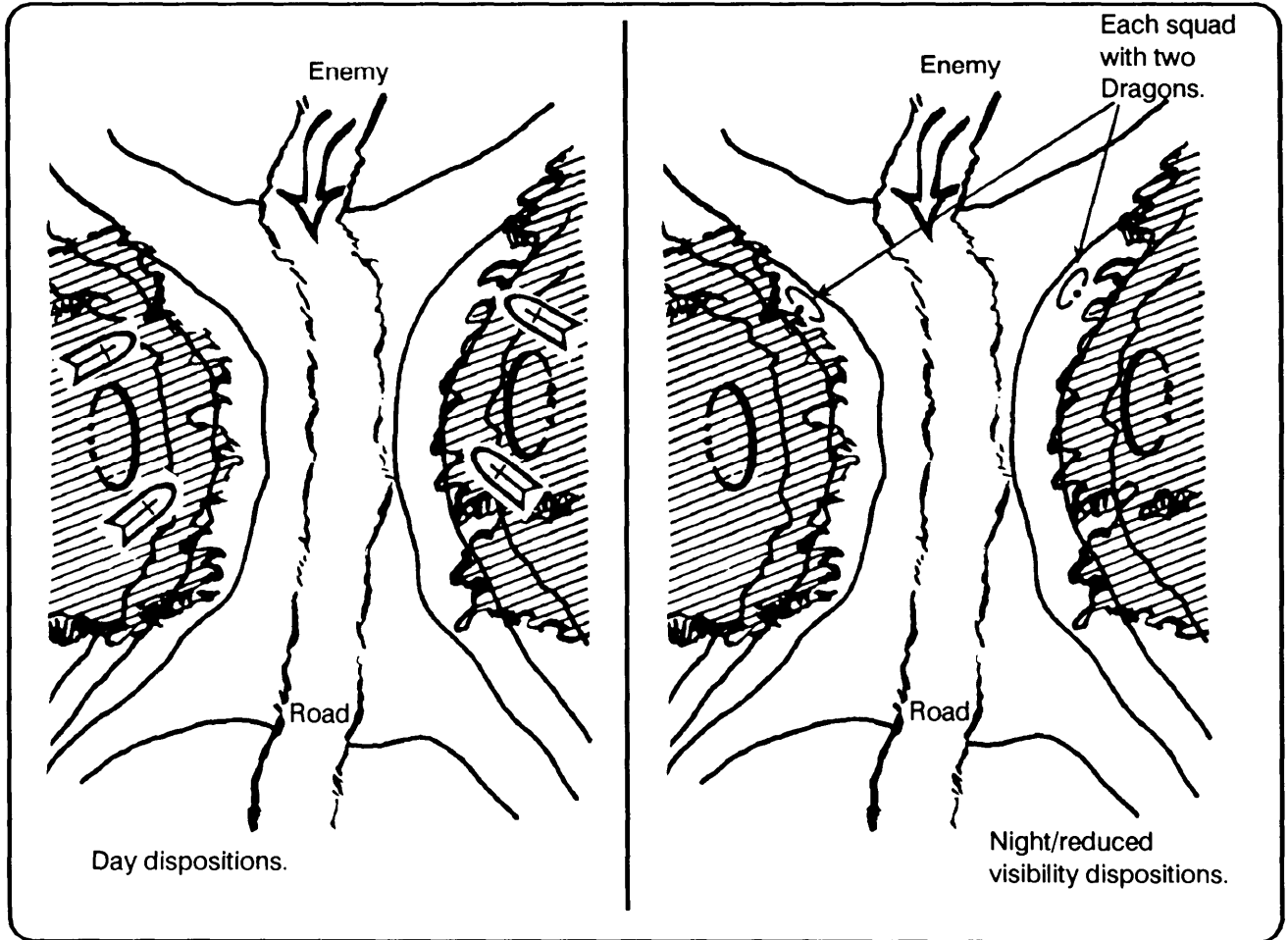

Figure 3-6. Night positioning of Dragons.

a. Covering Mine fields. When Dragons cover minefield, position them to engage approaching formations before reaching the minefield. This technique could cause the formation to deploy and enter the minefield at multiple points.

(1) Dragons engage an approaching column of tanks before they enter the minefield. (See A, Figure 3-7.)

(2) Tanks continue to deploy into the minefield and are destroyed by mines and Dragons. (See B, Figure 3-7.)

b. Using Obstacles. Obstacles are used as part of the overall defense plan to slow, canalize, stop, and kill enemy armor and protect friendly forces. Natural obstacles can enhance man-man obstacles. Dragon positions are selected to drive attacking tanks into these obstacles and to take the most advantage of flanking fire when tanks attempt to bypass them. Dragons can be placed to cover gaps and lanes in obstacles.

c. Resupplying and Prestocking Ammunition. Gunners request a resupply of rounds and other essential items through their chain of

command, which in turn passes on the request. During the course of an enemy attack, resupply of Dragon rounds to the platoon is often difficult. Therefore, extra rounds can be prestocked on the platoon's position. LAW and other ammunition can also be prestocked. Alternate and supplementary Dragon positions should be stocked with rounds to aid movement (rounds do not have to be carried) of the Dragon gunner to these positions. The unit should also plan for resupply of the AN/TAS-5 coolant cartridges and batteries.

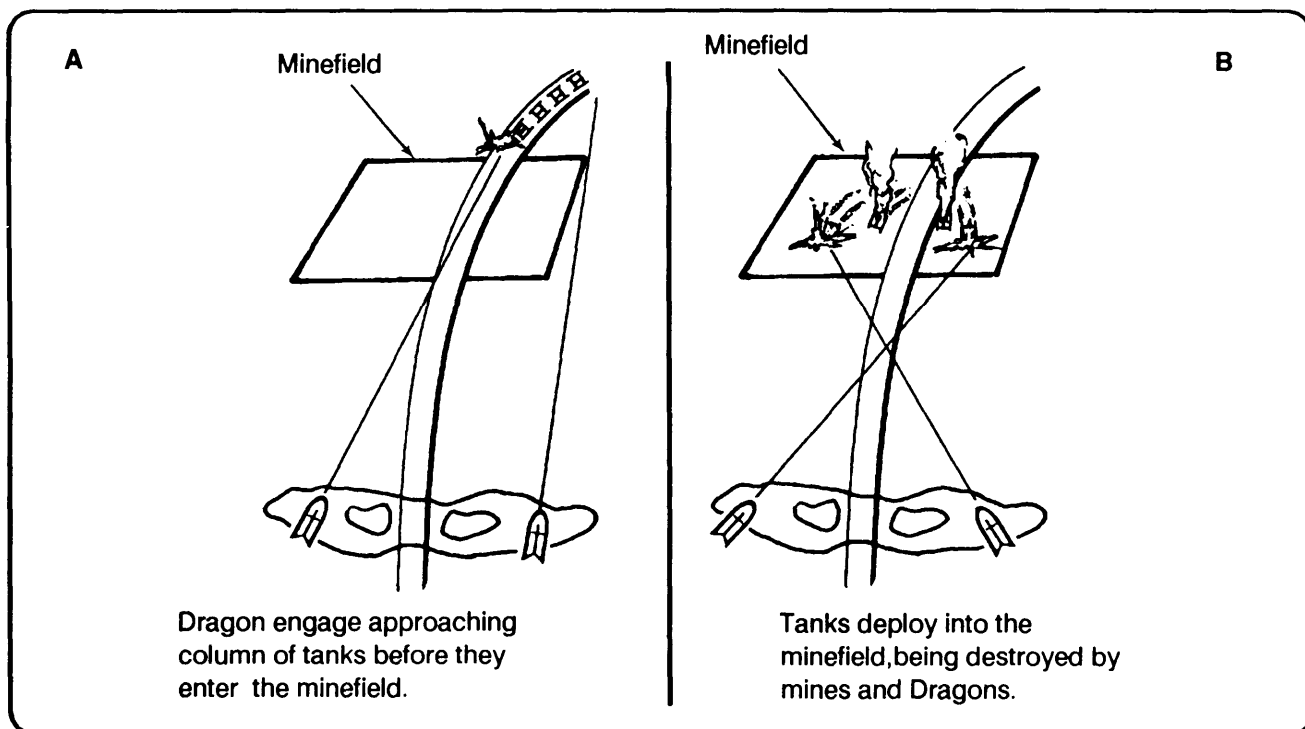

Figure 3-7. Covering minefield.

3-9. PREPARATION OF DRAGON FIGHTING POSITIONS

The Dragon fighting position must have unobstructed fields of fire, mask clearance (minimum dead space in the sector that could hide targets), and a clear backblast area. Like other weapons organic to the platoon, the Dragon can be employed from either hasty or improved positions. A fighting position is sited and oriented to cover a sector of fire

a. After receiving a sector of fire and firing location from the squad leader, the gunner constructs the Dragon position to cover the sector. When required, he clears fields of fire and only what is absolutely necessary. He camouflages the position using available materials,

and improves the position as time permits.

b. The backblast and the muzzle blast must be considered when employing the weapon. To prepare a fighting position for the Dragon, the gunner uses the following guidelines:

(1) When the weapon is fired from an improved position, the muzzle end of the launcher must extend 15 centimeters (6 inches) beyond the front of the hole. The rear of the launcher must extend out over the rear of the hole. As the missile leaves the launcher, the unfolding stabilizing fins require at least 15 centimeters (6 inches) of clearance above ground. The position should be protected to the front by a

parapet or by natural or man-made cover.

(2) The ground in front of and behind the position should be free of rocks, sand, and debris to prevent a dust cloud (caused by firing) from obscuring the gunner's vision, marking the location to enemy observers. When the Dragon is to fire in only one direction, a one-man fighting position is best. (See Figures 3-8 and 3-9.)

(3) The Dragon should be positioned to fire to the oblique so that its position can be protected from frontal fire while the target is being engaged from the flank. If necessary, the Dragon can fire to the front as well as to the oblique from a one-man fighting position.

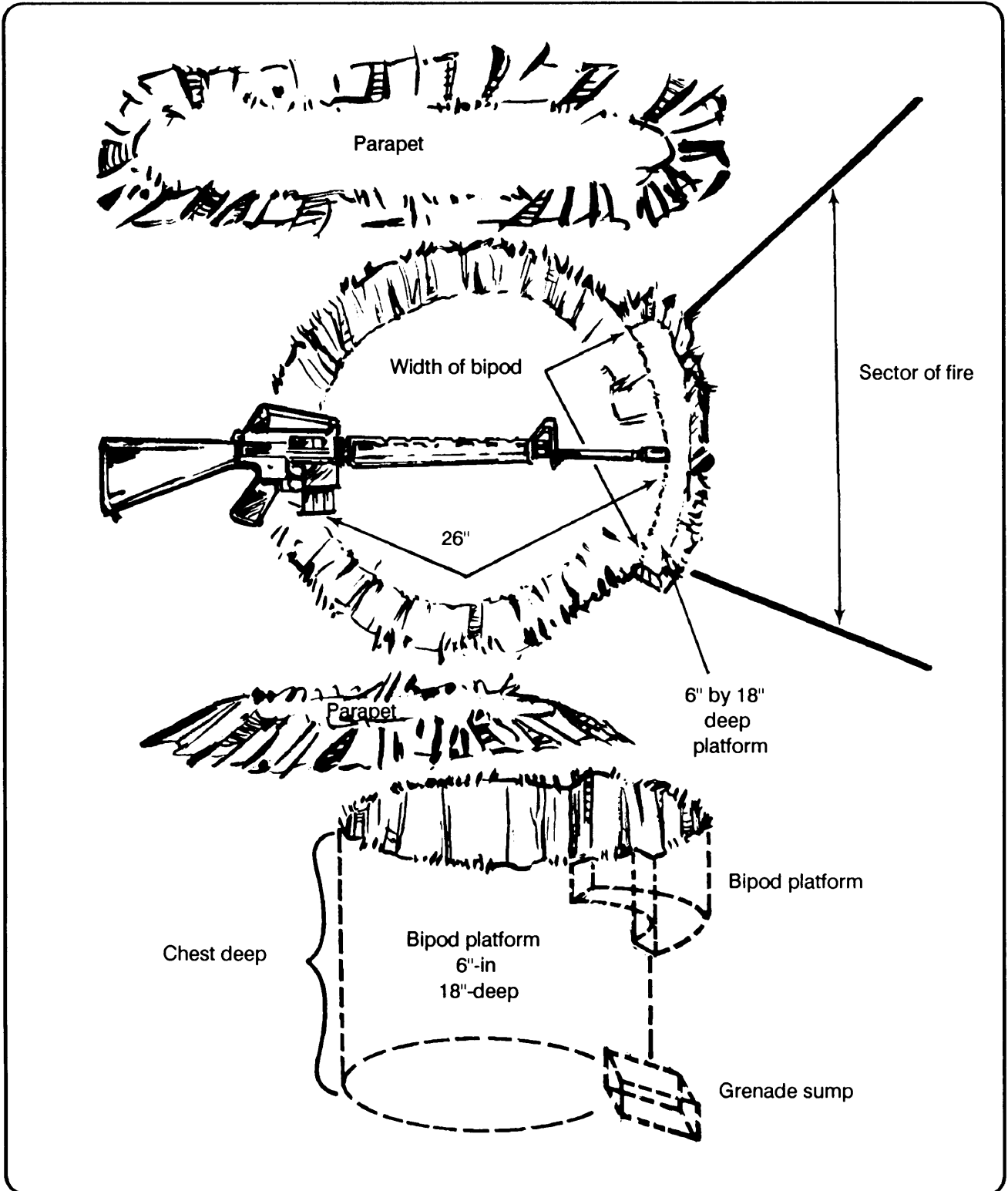

Figure 3-8. Construction of a one-man fighting position.

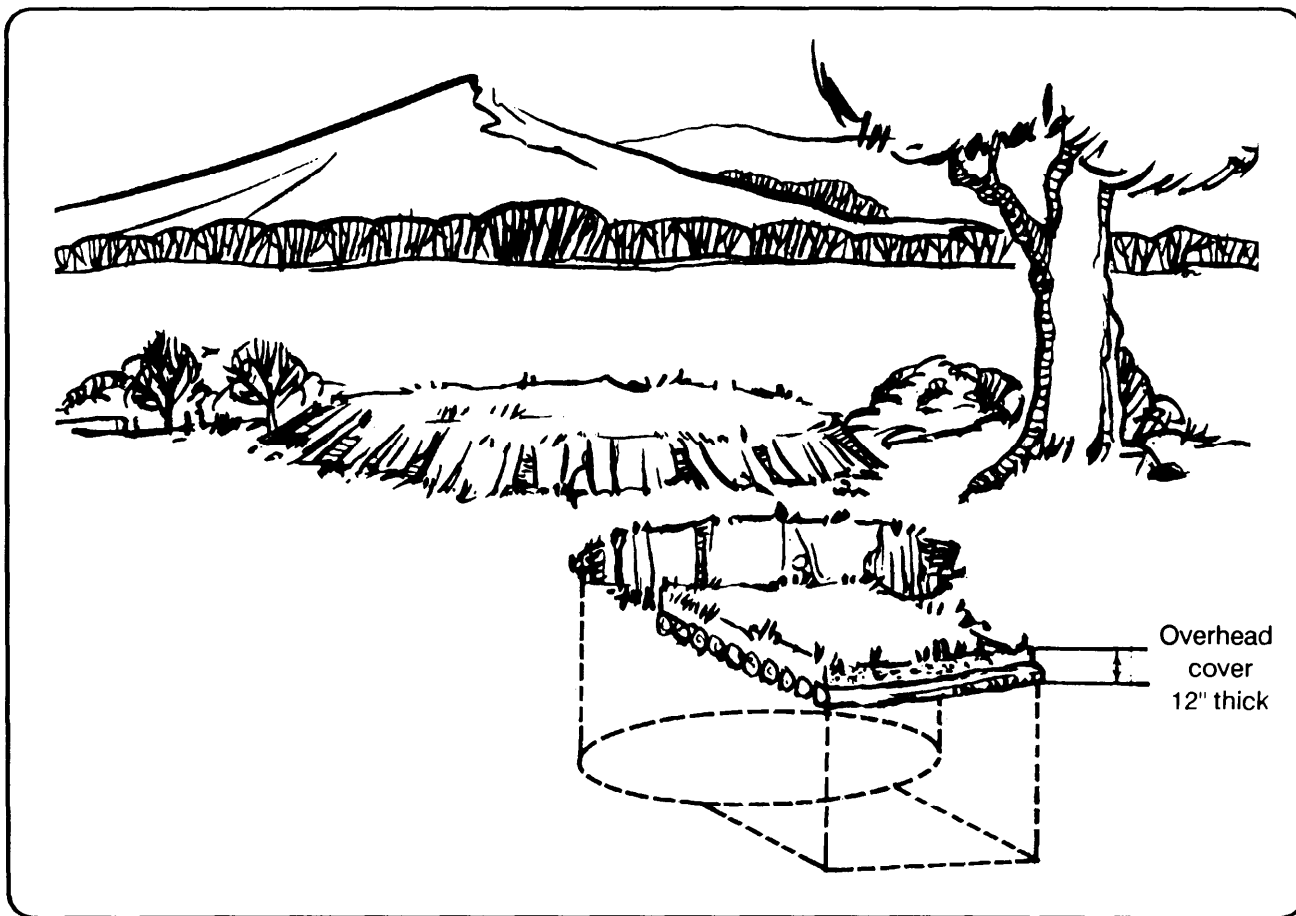

Figure 3-9. Construction of overhead cover.

(4) The two-man fighting position is wedge-shaped and it is best suited for use when more than one sector of fire can be covered from a single position. The design of the position gives the gunner frontal protection and allows the targets to be engaged from the oblique or flank. Construction includes the following factors:

(a) The trench position (A, Figure 3-10) should be constructed about three M16s long and in an inverted V-shape, waist-deep, and waist-wide, plus about 6 inches.

(b) The front parapet (B, Figure 3-10) should be one M16 long, one M16 wide, and two helmets high. It is placed in front of the trench.

(c) The grenade sump (C, Figure 3-10) should be one entrenching tool length long, one entrenching tool deep, and one entrenching tool blade wide. The floor of the main trench should slope gently from each end to the center and from the rear to the front.

(d) The overhead cover (D, Figure 3-10) at each end of the trench should be large enough to provide protection for one man and extra

rounds and be 12 inches deep, 18 inches over the sides, and 3 feet wide.

(e) Flank parapets (E, Figure 3-10) are at each end of the trench and should be one M16 wide, two helmets high, and long enough to provide good flank protection. The flank parapets are built on top of the overhead cover to increase overhead protection.

(f) Biped trenches (F, Figure 3-10) for each sector of fire should be dug with the back of the biped trench 4 to 6 inches forward of the main trench. The biped trench should be two helmets long, one helmet wide, and 6 inches deep.

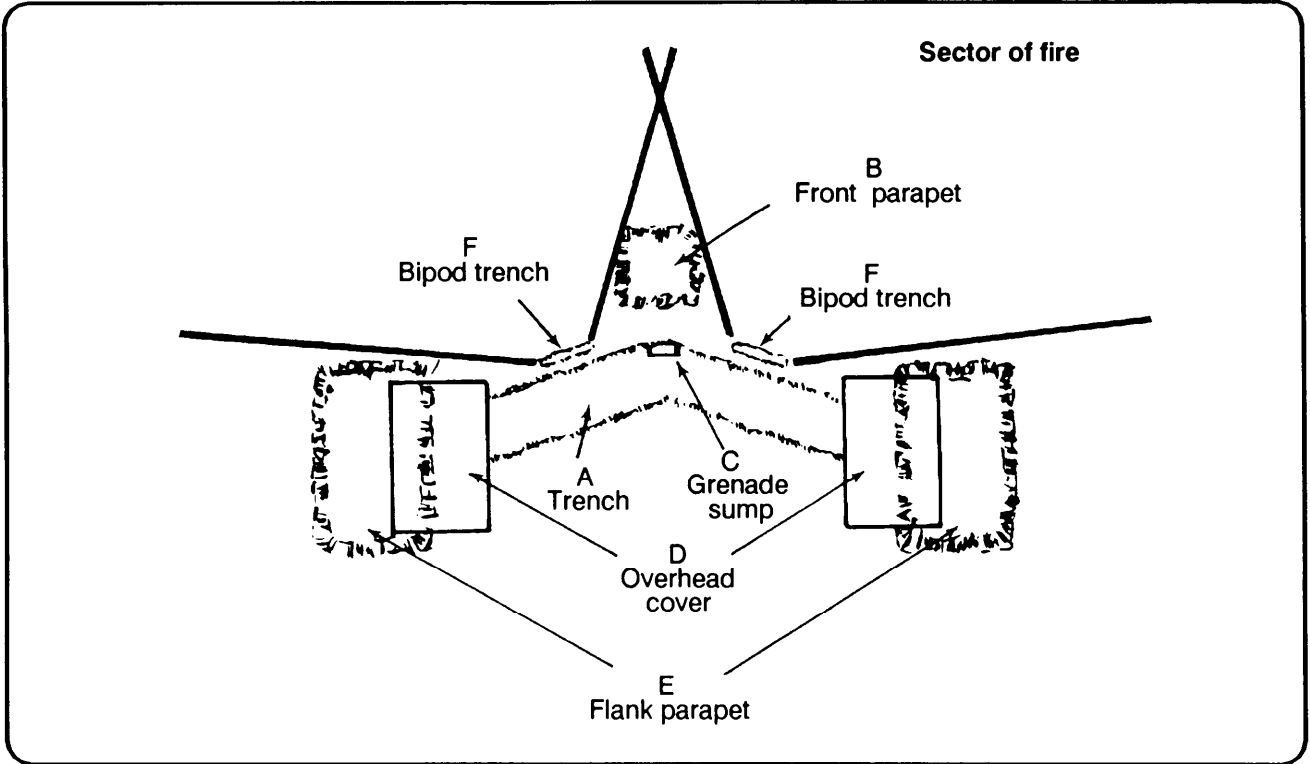

Figure 3-10. Construction of a two-man fighting position.

(g) At times, the Dragon maybe able to fire in only one direction (Figure 3-11); therefore, the position should

have cover to the front and targets should be engaged from the flank. The position is constructed to have

cover and concealment from all other directions.

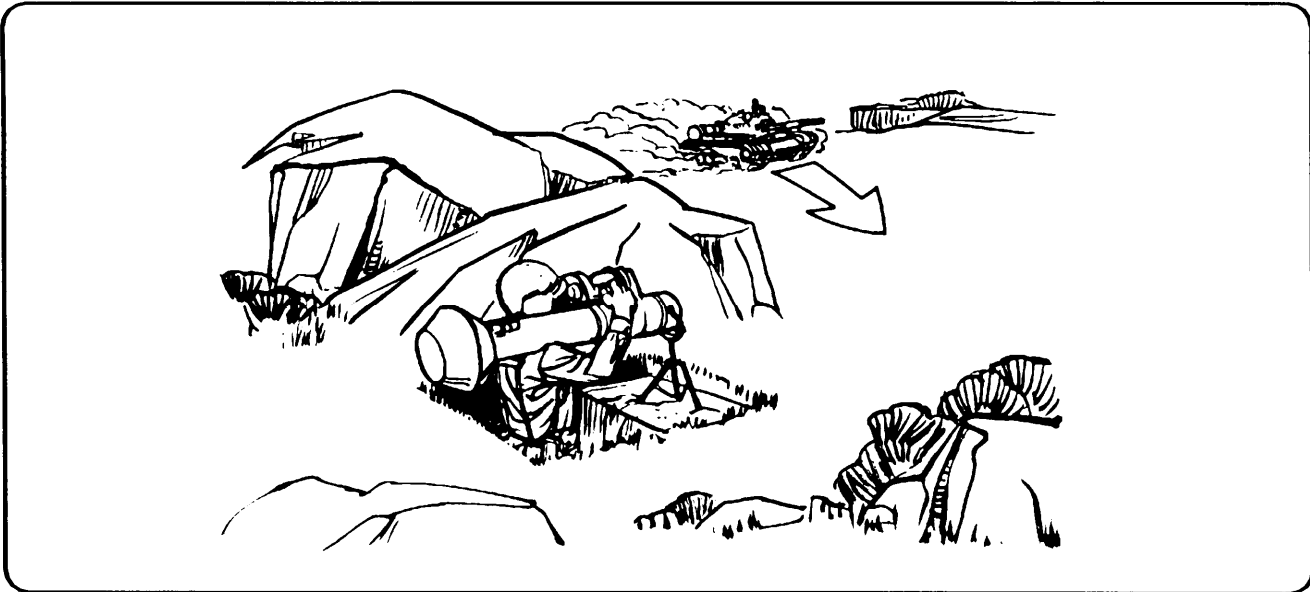

Figure 3-11. Firing in one direction.

3-10. FIRING FROM THE M113 APC

The primary method for firing the Dragon from a stationary M113 APC in a hull-defilade position is with the M175 mount. (See Figure 3-12.) The Dragon can also be fired using field-expedient methods from a stationary M113 in a hull-defilade position.

WARNING: To ensure the safety of personnel in the track, the driver's and cargo hatches must be closed.

a. Without using the M175 mount, the gunner stands in the track commander's hatch and places the bipod legs in the grill to fire the

weapon. (See Figure 3-13.) The gunner can also sit on the closed cargo hatch and fire the Dragon as if on the ground. (See Figure 3-14.)

b. The Dragon can also be dismounted from the APC and fired, using either the M3 or M122 machine gun tripod. (See Chapter 7.)

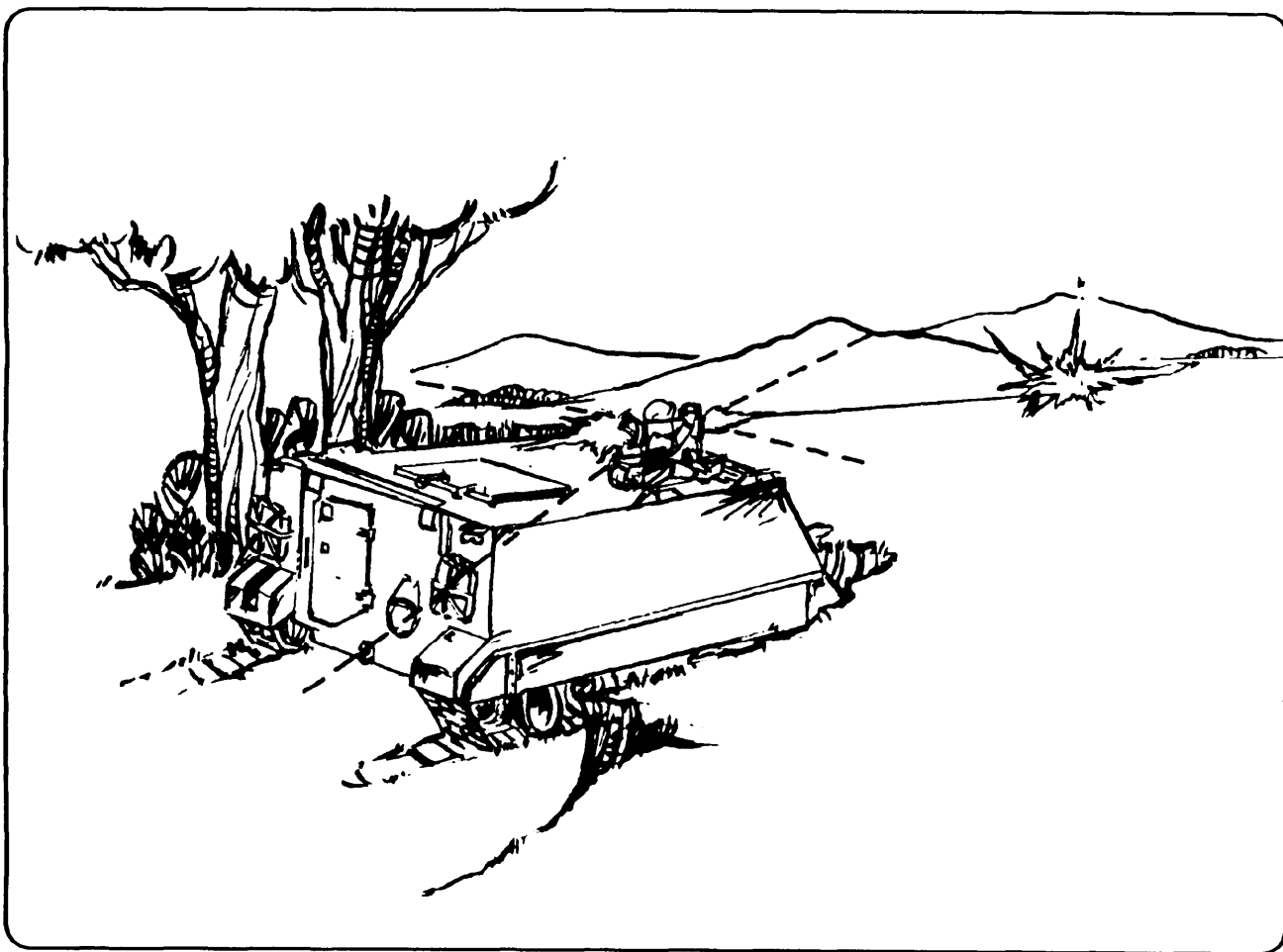

Figure 3-12. Firing Dragon from an M113 APC.

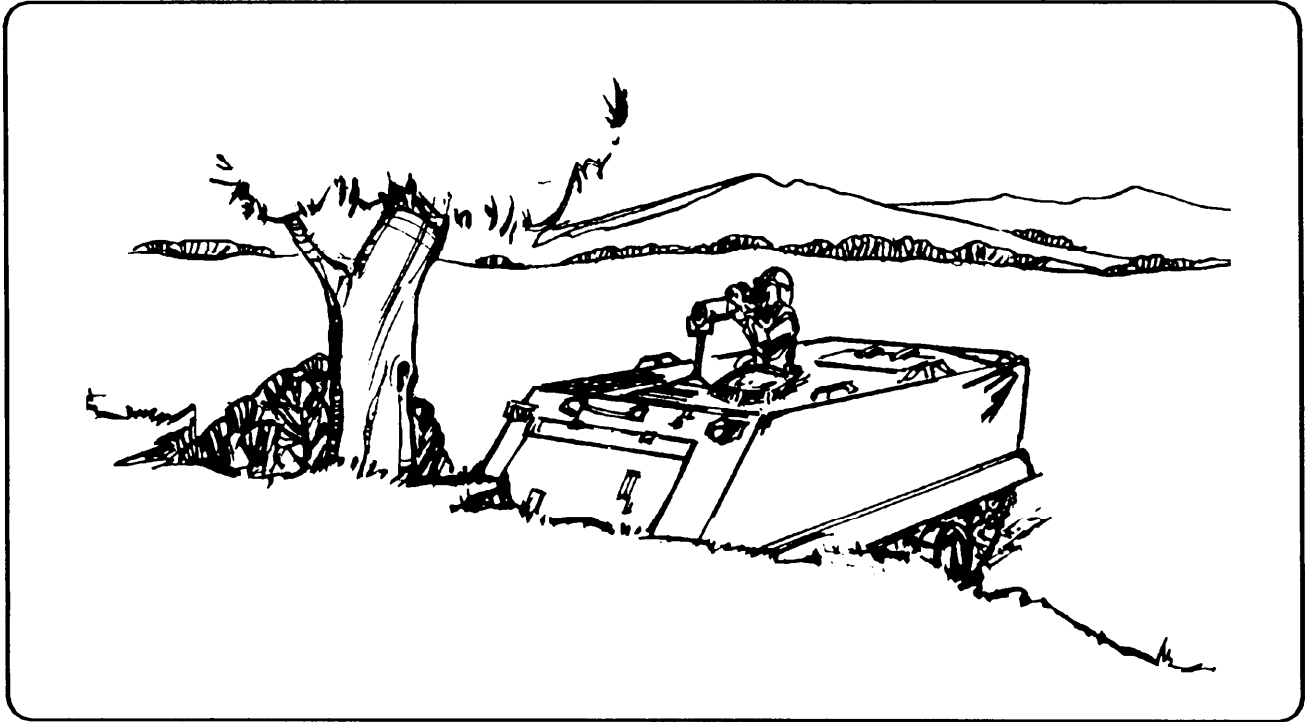

Figure 3-13. Firing the Dragon from commander's hatch.

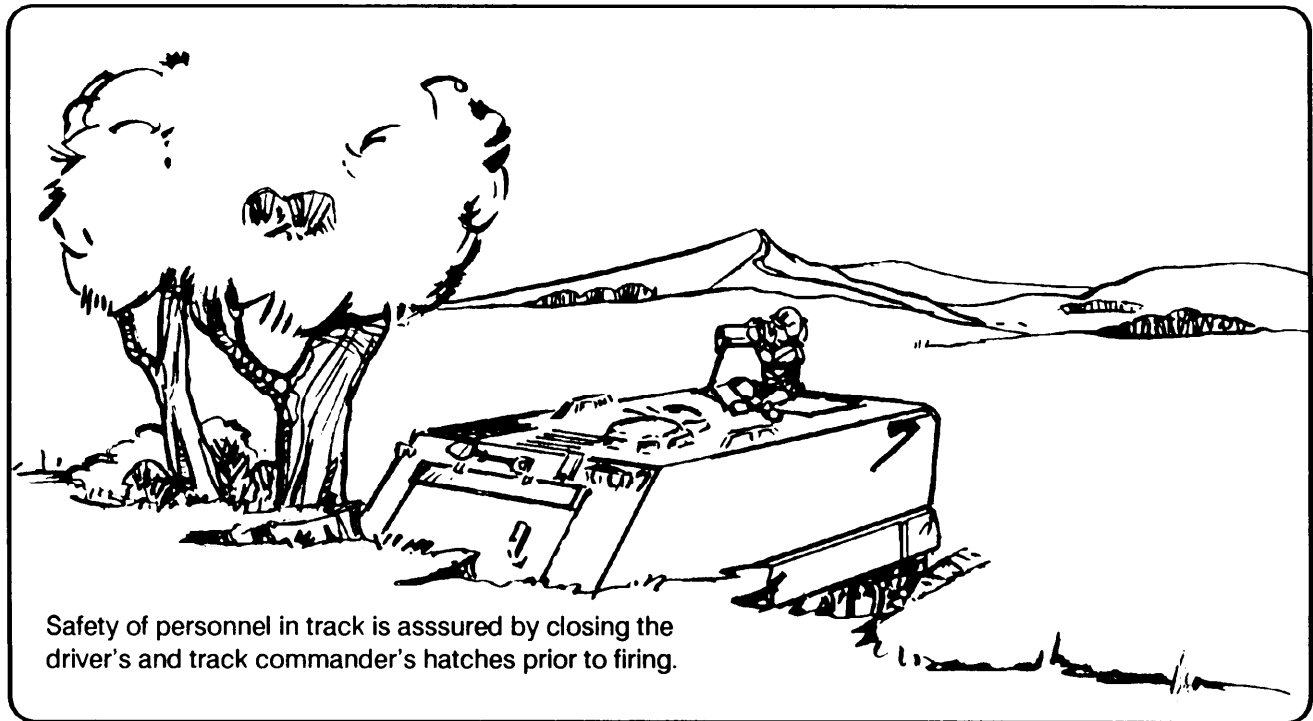

Figure 3-14. Gunner sitting on closed hatch.

3-11. PREPARATION OF RANGE CARDS

Range cards are essential for the rapid engagement of targets during all conditions of visibility and for quick resumption of a mission if the gunner becomes a casualty.

a. When the Dragon is ready to fire, the gunner normally prepares range cards in two copies: one copy is kept at the position and the other copy is given to the platoon leader. The gunner should also prepare range cards for alternate and supplementary positions.

b. A range card is a sketch of the terrain that a weapon system was assigned to cover by fire. It contains

information that helps to plan and control fires, to quickly detect and engage targets, and to orient replacement personnel or units. By using a range card, a gunner can quickly and accurately determine the information needed to engage targets. Two types of range cards are standard and field-expedient – both must include the following items:

- Weapon symbol, position, or both.
- Sector of fire.
- Maximum engagement line.
- Range and azimuth TRPs.

- Dead space.
- Distance and azimuth from a known point (gunner reference point).
- Magnetic north arrow.
- Data section.

(1) Standard Range Card. Once the leader provides the necessary information, the gunner prepares a standard range card (DA Form 5517-R). (See Figure 3-15.) The gunner prepares two copies of the range card.

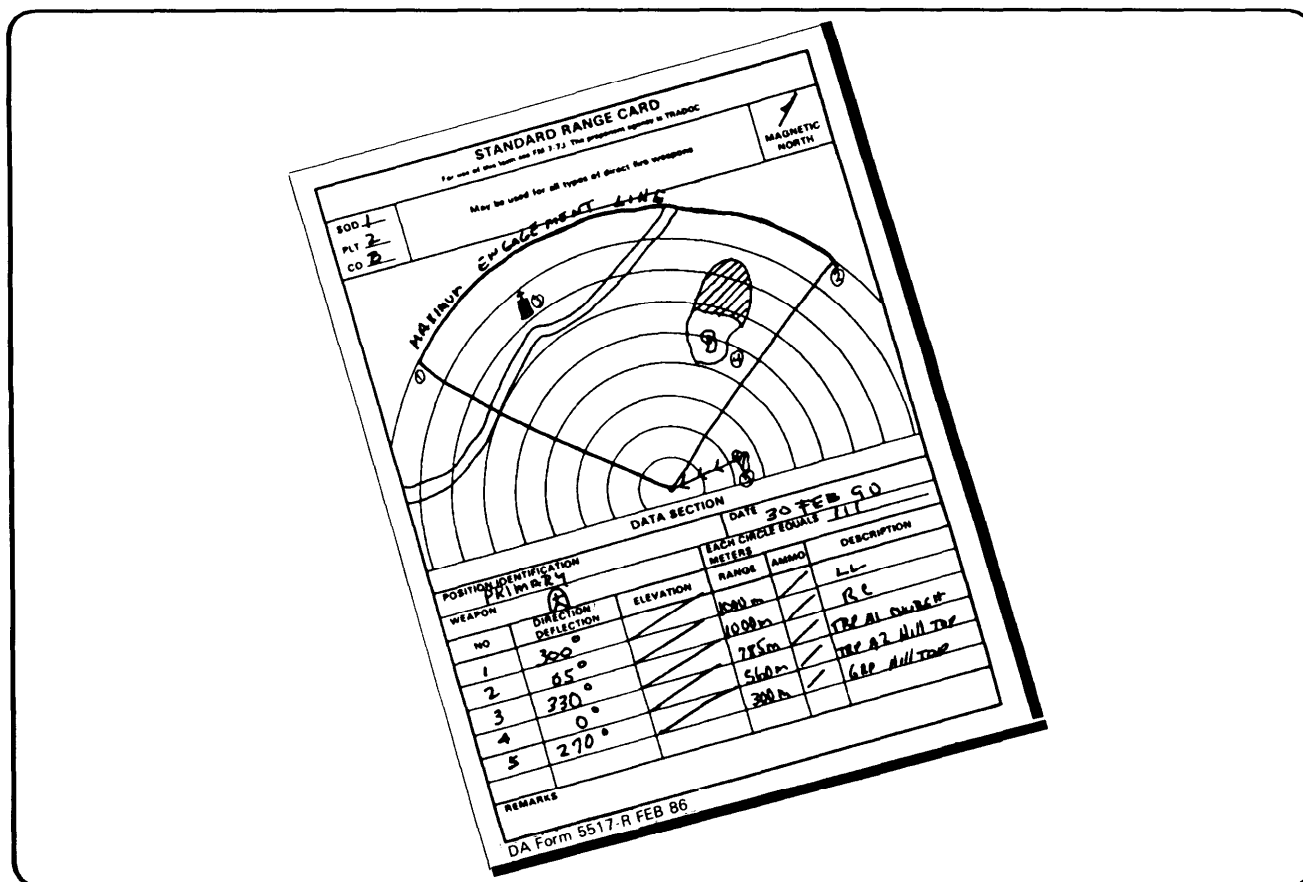

Figure 3-15. Example of completed standard range card, DA Form 5517-R.

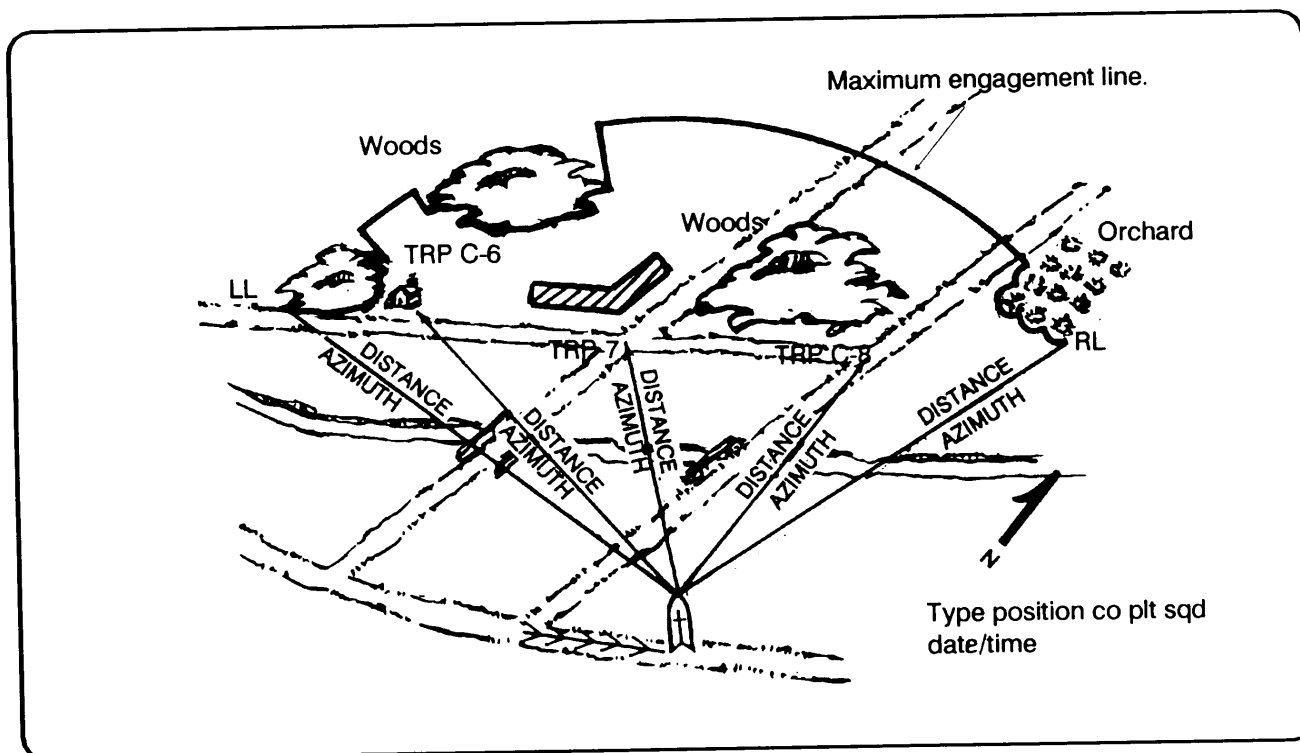

Figure 3-16. Expedient range card.

(2) Field-Expedient Range Card. In combat, a standard range card may not be available. The gunner may then draw a range card on anything

expedient range card (Figure 3-16) follows the same procedures as for any range card, but the weapon

symbol must be used to indicate the location of the weapon system.

3-12. TARGET IDENTIFICATION

Potential targets are identified as enemy by their activity, location, or signature (visual or otherwise) before they are engaged. To properly identify a possible target, squad members, and especially Dragon gunners, must be trained to recognize types of targets by their size, shape, and thermal image. (Particularly important is the size and shape of turret or main gun.) Friendly vehicle identification becomes more difficult when friendly foreign units are operating with or adjacent to US forces. The

ability to identify friend, foe, and types of vehicles is essential when a commander establishes target priorities. These target priorities require antiarmor weapons to engage specific types of enemy vehicles based on the enemy situation. The gunner must know the difference between tracked and wheeled vehicles since this can identify the type of unit: BTR-equipped or BMP-equipped. Each unit has its own organization and value to the gunner, S2, and intelligence community. The gunner

should simultaneously recognize the vehicle as friendly or threat and by nomenclature. He uses four basic STEPs to achieve target identification, combining the first three STEPs to achieve the fourth.

STEP 1. To detect (determine the presence of a vehicle).

STEP 2. To classify (determine if the vehicle is tracked or wheeled).

STEP 3. To recognize (determine if the vehicle is friendly or threat).

STEP 4. To identify (determine the nomenclature: T72, Vickers, MI).

a. Most weapons and vehicles have telltale signatures. Most tracked vehicles use diesel fuel, which emits a large amount of black smoke. They tend to make more noise than wheeled vehicles. Antiarmor units can use the different signatures to assist them in locating and in identifying enemy targets.

b. Target signatures are detected mainly by sight, sound, and smell. If anything suspicious or unusual is detected, it should be thoroughly investigated. The sun shining off a flat surface, such as a windshield, the sounds of diesel or turbine engines, or the clanking or squeaking of end connectors helps to detect and locate targets.

(1) *Soldier signatures.*

Ž Fighting positions.

- Trash.
- Cut or missing vegetation (cleared for fields of fire or camouflage).
- Freshly dug earth (may indicate a fighting position).
- Noise from equipment or talking.
- Light from a match, cigarette, or fire.

(2) *Tracked vehicle signatures.*

- Ž Large dust clouds.
- Ž Diesel smoke.
- Noise made by tracks and engine.
- Vehicle tracks on the ground.

Ž Distinctive silhouette or shape.

(3) *Antitank weapon signatures.*

Ž “Swish” of missile launch.

Ž Long, thin wires in brush, trees, or along the ground.

Ž Dismounted soldier looking through a periscope-type device. (Launcher could be up to 100 meters from the gunner.)

(4) *Aircraft signatures.*

Ž Reflection of the sun from aircraft canopies and rotor blades.

- Vapor trails.
- Dust and movement of foliage caused by a hovering helicopter.
- Sound of a turbine engine (high-pitched whirring sound).

(5) *Obstacles and mines.*

- Loose or disturbed dirt in a regular pattern.
- Areas where large trees were removed.

3-13. TARGET RECOGNITION BY TYPE (FRIENDLY OR THREAT)

Learning to recognize targets by type is not a difficult task, but identifying them as friendly or enemy requires careful study and attention to detail. This is especially true of tanks, because both friendly and threat tanks are quite similar in design. Side by side, they may appear different, but if camouflage is added and at a distance of 1,500 or 2,000 meters, the difference is unclear. Soldiers must know which friendly and threat armored vehicles could appear on the battlefield. Training aids, such as GTA 17-2-13, can be used to study the armored vehicles of other nations (Figure 3-17).

NOTE: Characteristics of common enemy armored

vehicles are contained in STP 21-1 -SMCT.

a. The type, location, and absence or presence of certain equipment in the suspension system, turret, or main gun aid in identifying most armored vehicles or tanks. Threat forces, however, also practice camouflage and deception procedures.

b. Reactive armor and increased use of sandbags can nullify antiarmor weapons and greatly alter the shape of vehicles.

(1) *Suspension system.* This is the least reliable area for identification as it is often concealed by vegetation or by terrain. Characteristics of the

suspension system that can be used to distinguish tanks are –

- Road wheels and support rollers.
- Road wheels only.
- Number of road wheels.
- Spacing between road wheels.
- Armored skirt.

(2) *Turret.* Characteristics of the turret that can be used to distinguish tanks are –

- Position on the hull: well forward, center, or to the rear.
- Presence, absence, or location of searchlight.

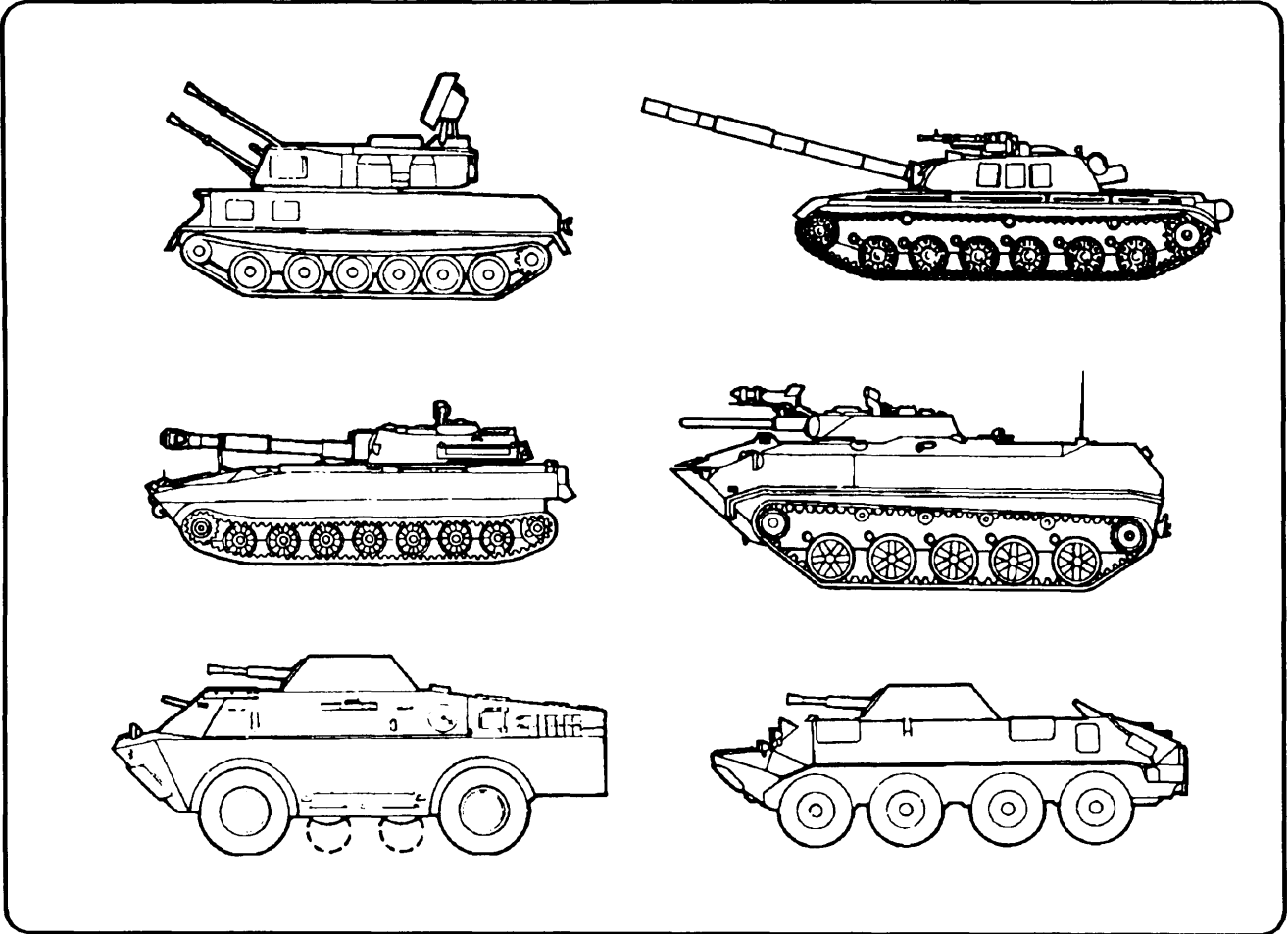

Figure 3-17. Differences between armored vehicles.

- Shape of turret, rounded, elongated, or boxy.
 - The presence and location along the gun tube of a bore evacuator.
 - The presence of a muzzle brake or blast deflector.
 - The presence or absence of a thermal jacket.
- (3) *Main gun.* Characteristics of the tank main gun that can be used to distinguish tanks are –
- Externally mounted storage racks and other equipment.
 - *Commander's station (some tanks).* This is usually a simple hatch or a cupola. A cupola is a small turret-like projection on the top of the turret that houses the commander's station either on the right or left side,

3-14. THERMAL IDENTIFICATION

Identifying targets with the AN/TAS-5 by thermal signature is extremely difficult and requires extensive training. Appendix A provides a detailed discussion on identification of targets using thermal signature. The four STEPs of vehicle identification that the

gunner uses during the day are also used for thermal identification.

Section III. TARGET ENGAGEMENT

Before a Dragon missile is fired at an enemy target, it must be determined if the target can be engaged. A target can be engaged if it –

- Is within the range of the missile.
- Is exposed so that it can be identified and tracked by the gunner.
- Will remain exposed for the time it takes the missile to fly to the target.

3-15. TARGET ENGAGEMENT TECHNIQUES

Target engagement is affected by firing limitations (power lines, smoke, fog, and ground clearance). The gunner assumes a firing position to observe the assigned sector of fire. Then he sights through the tracker to observe for enemy targets. Once he

sights a target, the gunner makes adjustments to his tracker as follows:

a. Day Tracker. The gunner focuses the sight by holding the reticle adjustment ring stationary while rotating the eye guard to fit the eye.

b. Night Tracker. The gunner adjusts the reticle focus adjustment, range focus lever, and contrast and brightness controls for the best possible picture of the stadia lines, target area, and target.

3-16. RANGE DETERMINATION

The Dragon gunners use the stadia lines in the day and night trackers to determine if a target is within range. Three different types of moving and stationary targets are flank, oblique, and frontal or rear. (See A, Figure 3-18.) A target 20 feet (6.09 meters in length) completely fills the area between the stadia lines at maximum range (1,000 meters) and exceeds the stadia lines at a closer range.

a. Flanking Targets (Full Stadia). Adjust the sight picture by moving the launcher to center the target between the stadia lines. (See B, Figure 3-18.)

b. Oblique Targets. If more of the flank is visible, use the full-stadia method. (C, Figure 3-18). If more of the front or rear is visible, use the

half-stadia method. (See D, Figure 3-18.)

c. Frontal (Head-On) on Rear (Going Away) Targets (Half-Stadia). Adjust the picture by moving the launcher to align the vertical cross hair and one of the stadia lines on the target. (See E, Figure 3-18.)

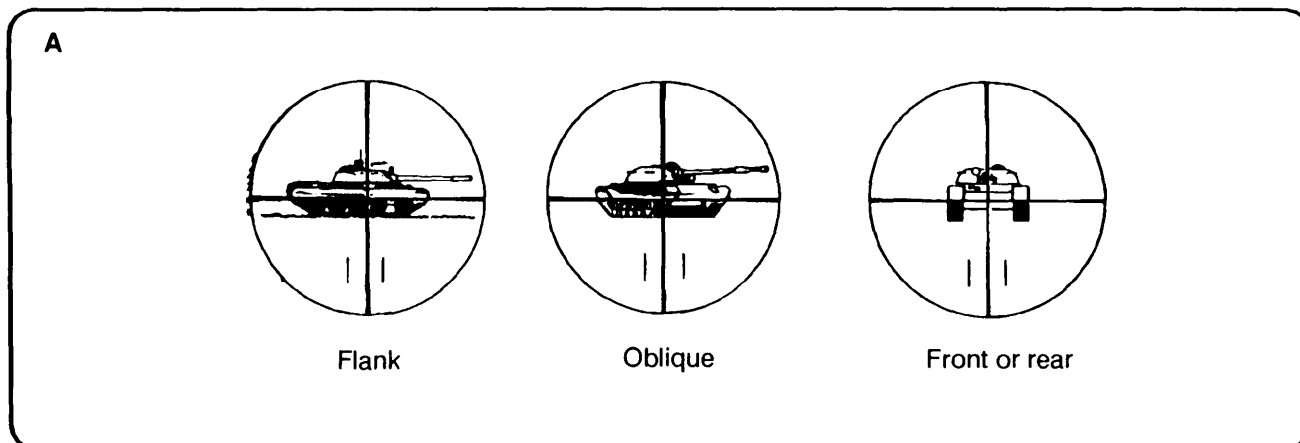

Figure 3-18. Range determination.

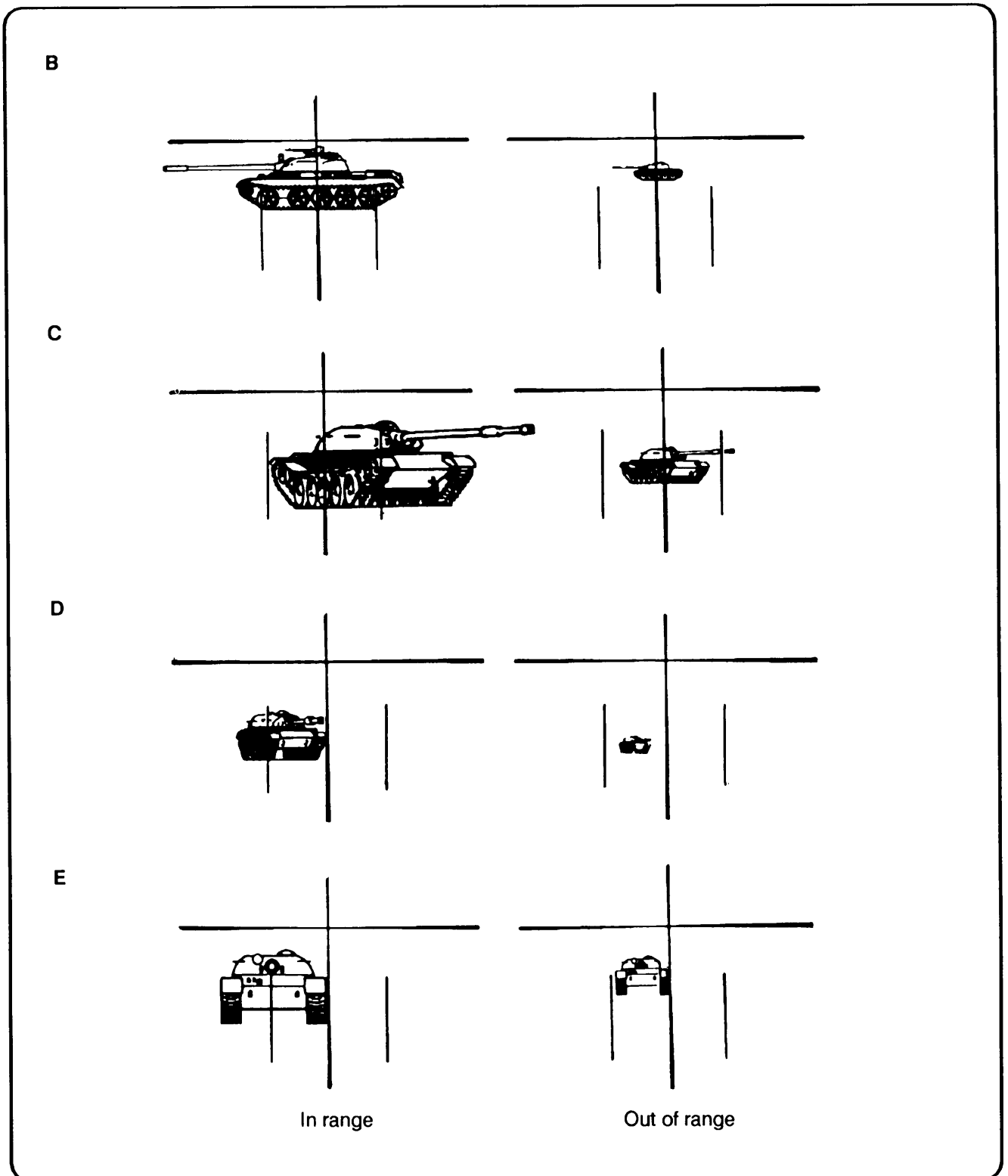

Figure 3-18. Range determination (continued).

3-17. TIME/SPACE FACTOR

The gunner uses the time or space factor to determine if a target can be engaged.

a. A moving target may be able to find a covered position if the gunner can judge whether the missile will successfully hit the target after launch. The tracker sight helps make

this determination. The gunner lines up the tracker sight directly in front of the target. If there are no obstructions or covered areas along the expected path of the target and the target is moving 35 kmph or less, the gunner can successfully launch and destroy it. (See A, Figure 3-19.)

b. The gunner places the cross hairs center of mass and fires – the target will not be able to reach the protection of the hill in time. (See B, Figure 3-19.) If the gunner does fire – the target will reach the protection of the hill before the missile hits. (See C, Figure 3-19.)

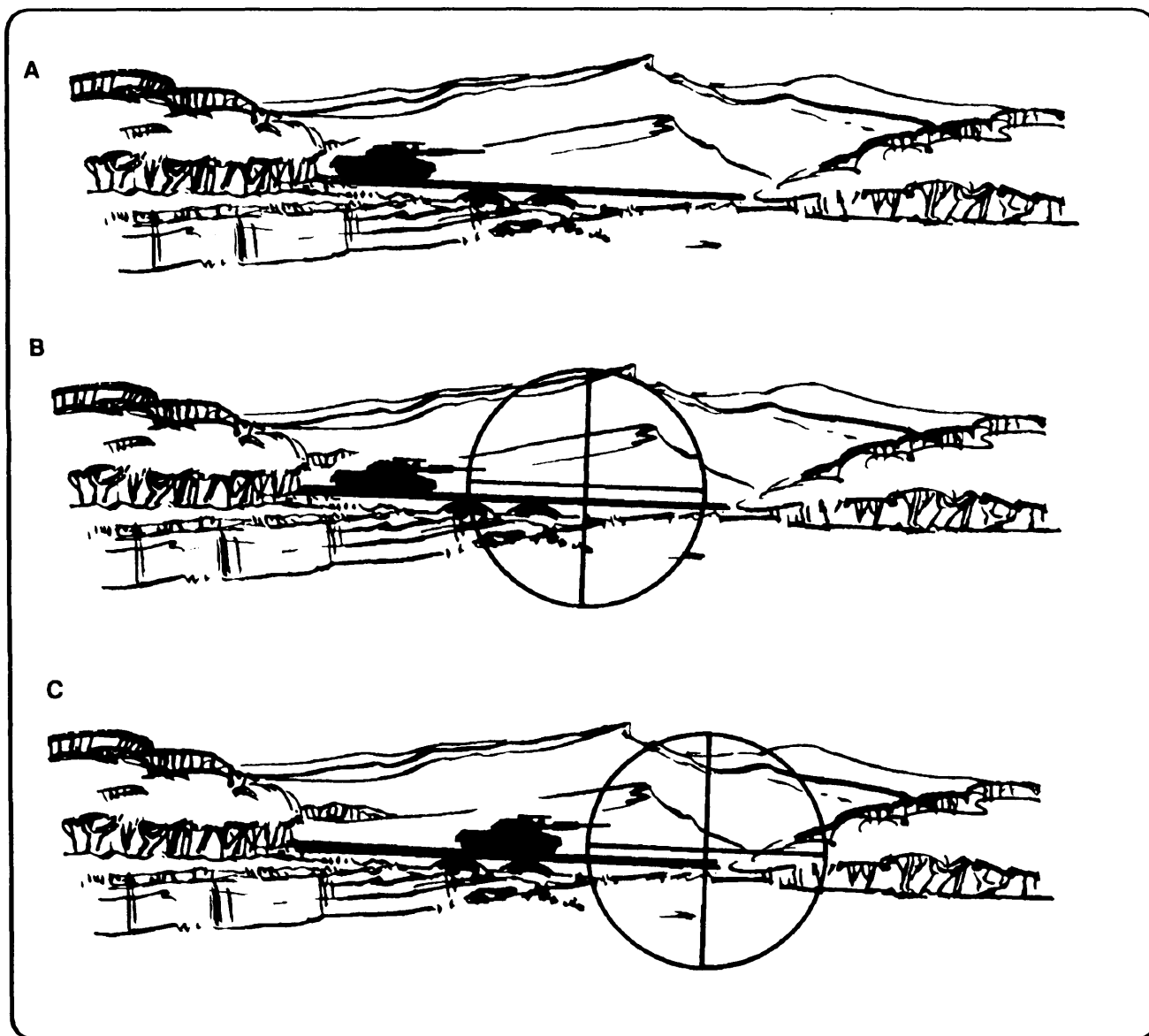

Figure 3-19. Target determination.

3-18. VULNERABLE POINTS OF ARMORED VEHICLES

After the gunner decides that a target can be engaged, he should strive to hit enemy targets in their weakest points. Leaders can assist by positioning Dragons to take advantage of these weak points.

a. Most threat armored vehicles are rugged, simple in design, and operationally effective. To increase the lethality of antiarmor weapon systems, the gunner must attempt to engage the threat vehicle in its weakest point, which includes the internal fuel and ammunition storage areas, as well as the engine. Destruction of the engine not only

immobilizes the vehicle, but possibly ignites ruptured fuel lines to cause a fire.

b. Armored vehicles are built with the greatest armor protection on the front glacis of the tank. Moving from the front of the vehicle to the oblique and flank areas of an enemy armored vehicle increases the probability of a kill. The armor plating is not as thick in these areas, and the angle causing projectile deflection is less pronounced. Also, visual observation by the enemy crew is degraded. Flank areas can be exposed when the threat vehicle

attempts to bypass an obstacle or to evade an oncoming ATGM.

c. Frontal fire is usually avoided. An antitank weapon firing frontally is an exception. A tank's firepower and observation are oriented to the front. This makes it difficult to detect and retrace an ATGM launched from its flank. Firing at frontal targets lowers the odds for a mobility kill, which can be acquired by hitting the vehicle's wheels, track, or suspension system. The highest-percentage of mobility kills result from flank and oblique target shots. (See Figure 3-20.)

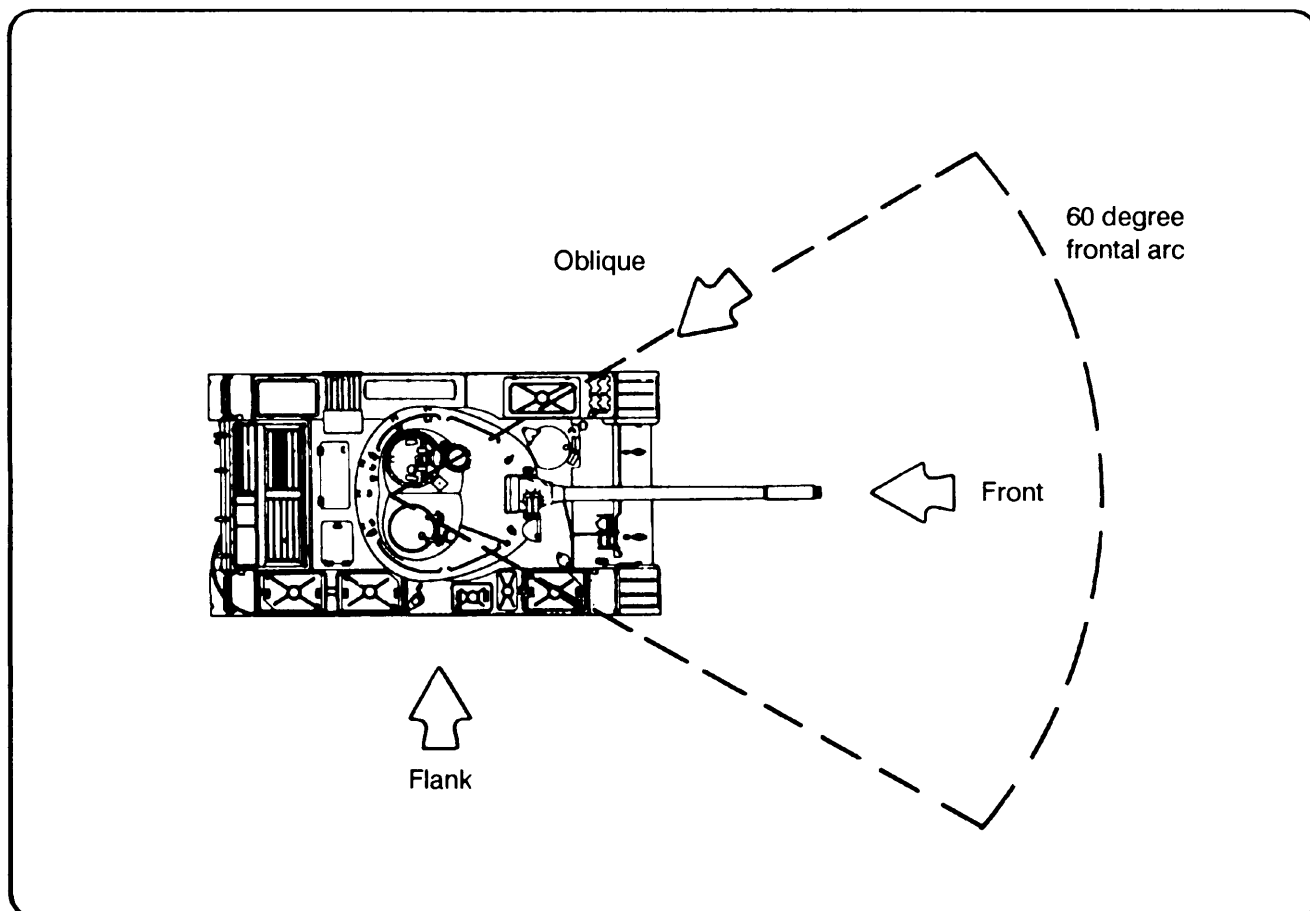

Figure 3-20. Flank and oblique target shots.

d. The armor and the angle causing projectile deflection are minimal to the rear of the threat armored vehicle. The engine compartment of the vehicle is extremely vulnerable to antitank weapons fire.

e. Other areas where a threat armored vehicle is weak are the top and bottom (belly). These areas may become exposed while the vehicle is breaching an antitank ditch, fording a river with steep banks, or

traversing a shallow valley. Careful terrain analysis of assigned sectors of fire by friendly antiarmor elements can identify areas where approaching armor units must expose their weaker areas.

3-19. FIRE CONTROL

The platoon leader normally controls Dragon fires by assigning sectors of fire for each Dragon gunner. Once the initial command to fire is given, gunners can engage any enemy armor vehicle in this sector. The platoon leader gives fire commands to shift Dragon fires from other than the primary sectors. Well-planned and executed fire

control measures are critical to the effectiveness of Dragon fire. Dragon positions should not be endangered by premature fires in which either the range is excessive or the target is not in position to ensure a high probability of a first-round kill. Proper fire control ensures that Dragons engage targets at optimum times. Only the best sited weapon in

relation to the target opens fire. Uncontrolled firing decreases the effectiveness of the unit's overall antiarmor capabilities. Dragons that are dispersed as much as 1,600 to 2,000 meters can, under ideal conditions, concentrate their fire on the same group of targets. (See Figure 3-21.)

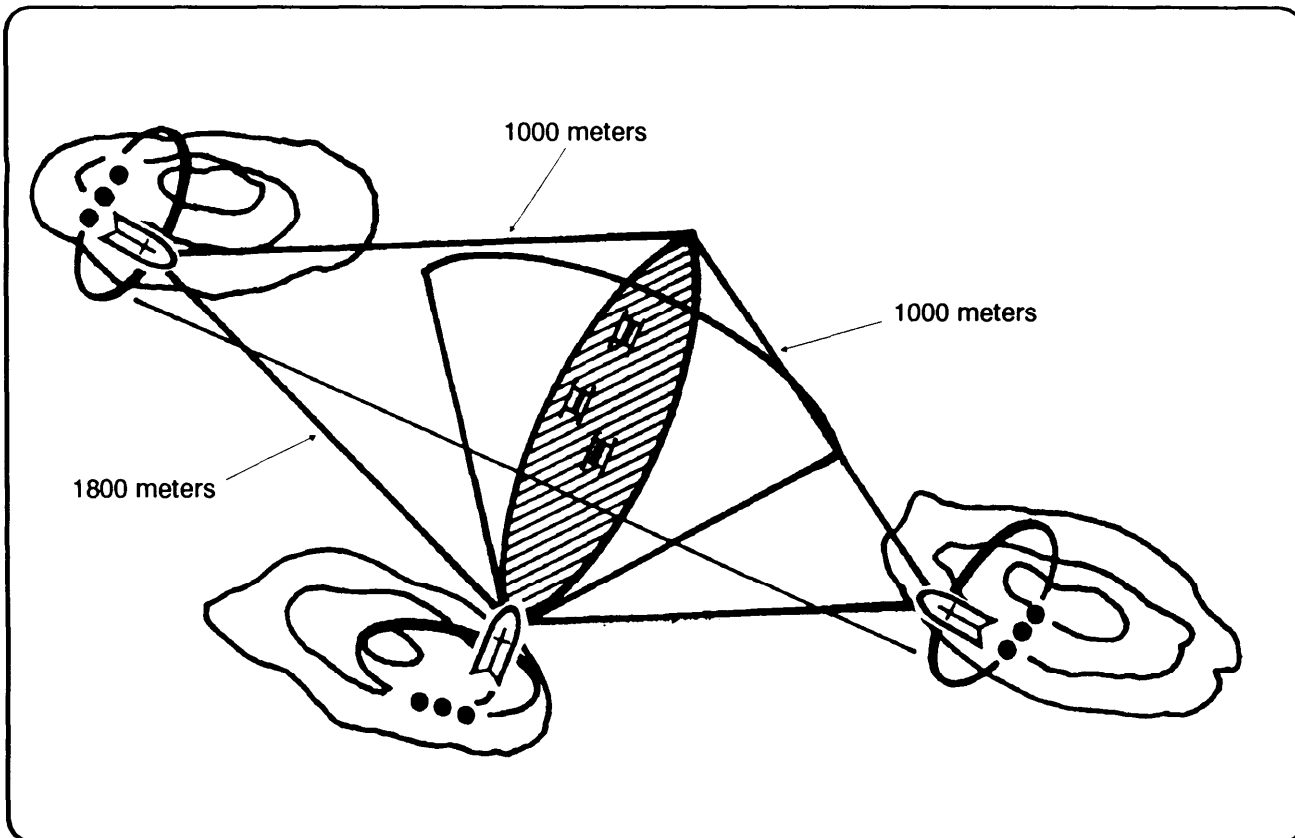

Figure 3-21. Dragon dispersion.

a. Fire Control Methods. To exploit the capability to concentrate Dragon fire from widely dispersed firing positions and to overcome possible difficulties caused by a limited communications capability, effective fire control methods must be

practiced when employing a Dragon. (See Figure 3-22.) Effective fire control methods prevent the wasteful firing of more than one Dragon missile at the same target and prevent premature firings. These fires might unnecessarily

disclose the location of the defensive positions. The primary control methods used to control the fire of one or more Dragons are sectors of fire, TRPs, engagement priorities, fire patterns, and fire commands.

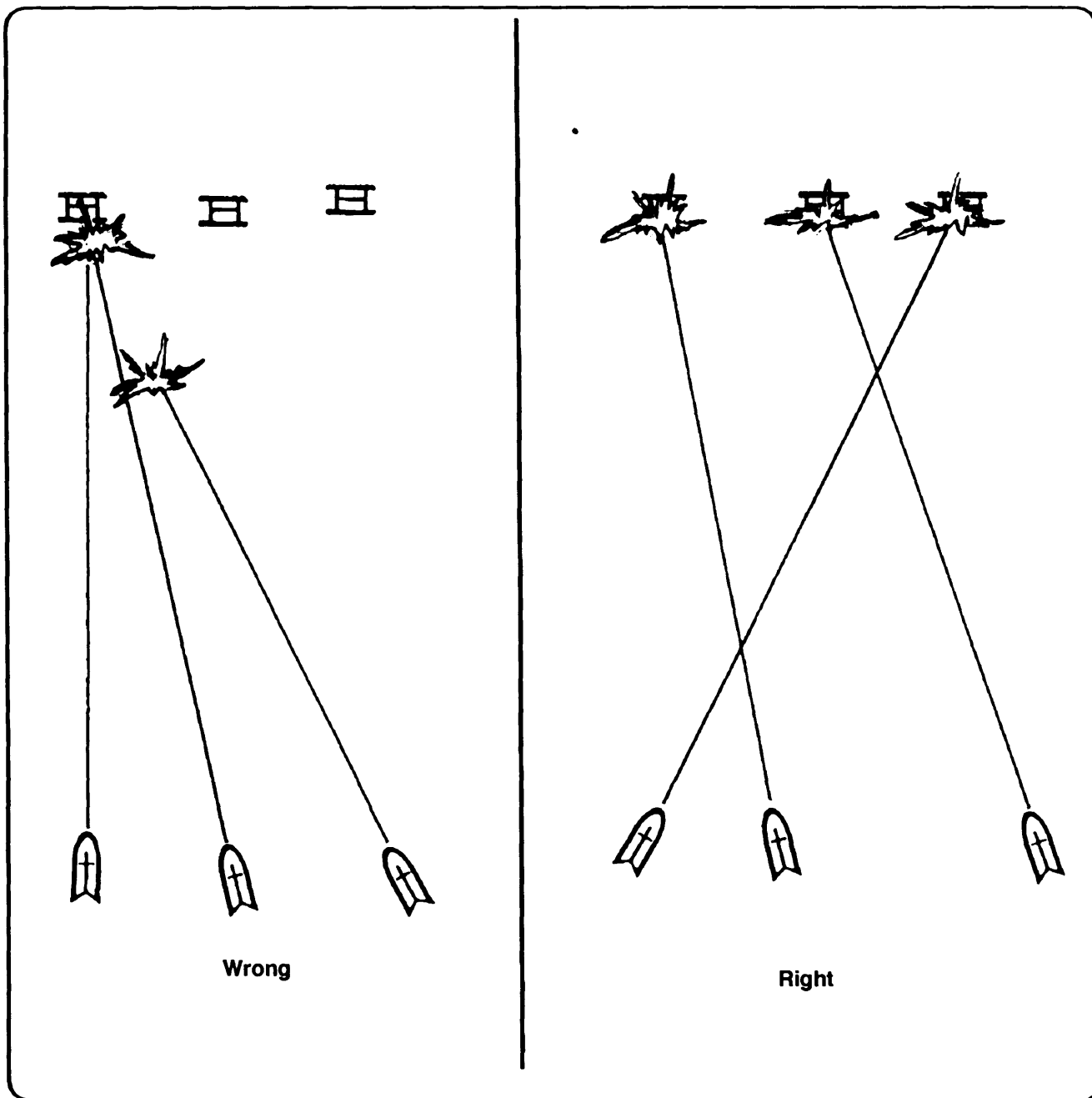

Figure 3-22. Fire distribution.

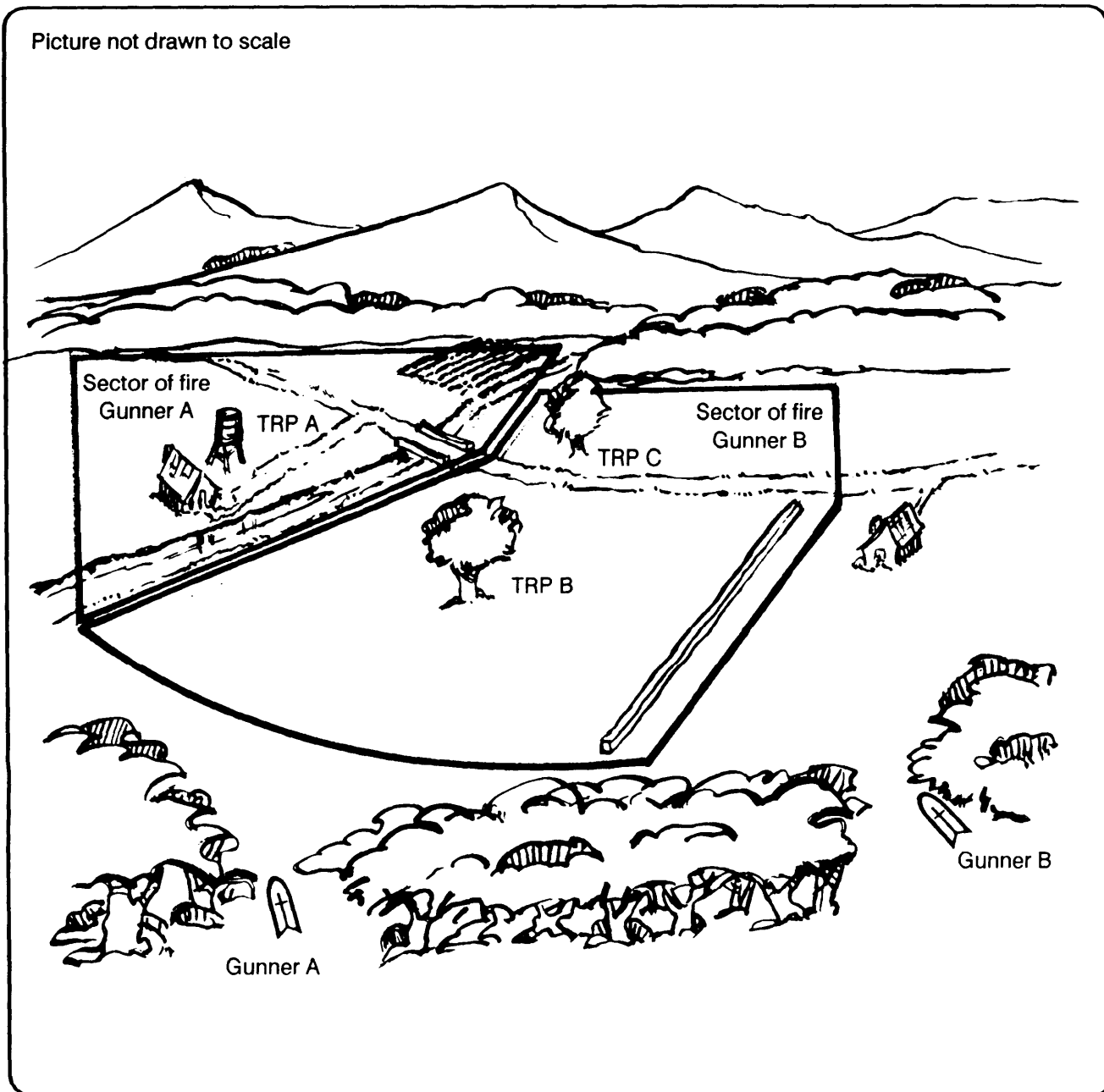

Figure 3-23. Sector of fire.

b. Sector of Fire. A sector of fire is an area, limited by boundaries, assigned to a unit or a weapon to cover by fire. (See Figure 3-23.) A gunner needs to know how many TRPs are in and around his sector and where they are located, if other sectors need assistance.

c. Target Reference Point. A TRP is an easily recognizable point on the ground, either natural or man-made. The TRP is used as a reference point for locating targets and controlling fire. They are normally all referenced by a lettering or numbering system. TRPs are also

used to control and shift fires; that is, "Dragon One, engage west of ALPHA. Dragon Two, engage east of ALPHA, on my command." (See Figure 3-24.)

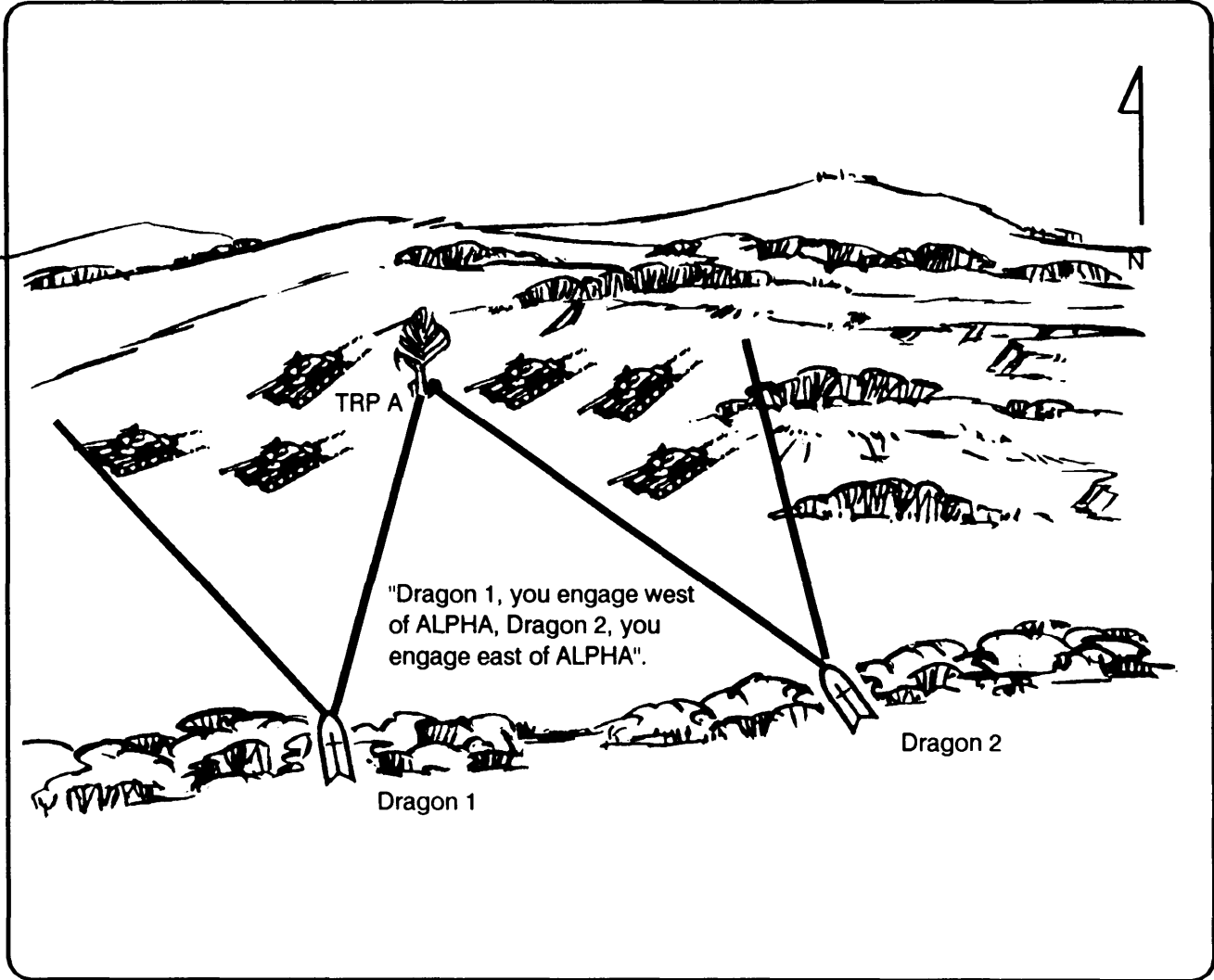

Figure 3-24. Use of target reference point.

d. Engagement Priorities. Engagement priorities are the priorities by which types of vehicles in a formation are engaged. Dragons are better suited to killing command and control vehicles, APCs, and CFVs because of the improvement in threat tanks' armored protection. When available, units should kill enemy tanks with TOW and tanks. However, any type of enemy armor vehicle is a suitable target and should be destroyed. Once the battle is joined, each gunner covers his

assigned sector or portion of a kill zone. If multiple targets appear in his area, he takes the best shot for a first-round kill. A priority of engagement by type of vehicle can be assigned by the commander; for example, if enemy antiaircraft fire prevents the Air Force or attack helicopters from operating in the forward battle area, destruction of antiaircraft weapons may be given priority; if long-range enemy ATGMs reduce effective

employment of friendly tanks, they may be assigned as a priority target.

e. Fire Patterns. Fire patterns describe the relationship between firing Dragons and their targets. These patterns can be used in fire commands or fire plans, within the section or within the team. They can also be used with other control measures such as priority of fires. Two basic patterns are cross fire and depth free. (See Figure 3-25.)

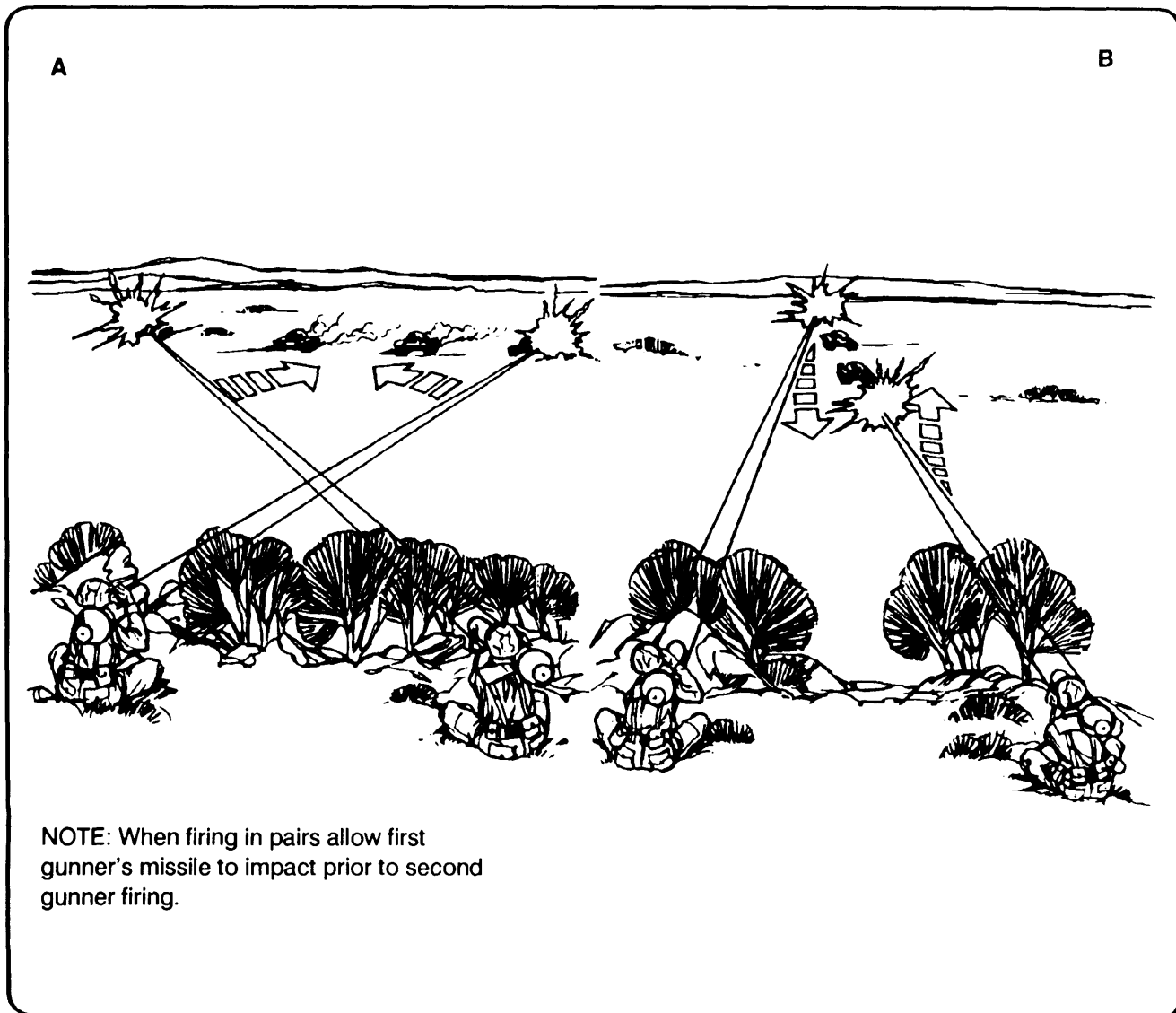

Figure 3-25. Fire patterns.

(1) *Crossfire*. Cross fire is used when targets are dispersed laterally or obstructions prevent the Dragon from firing to the front. When using cross fire, gunners must stagger their fires. When the first missile impacts, the next gunner may fire. Cross fire prevents either gunner from picking up the other missile's infrared flare (trying to guide two missiles or the wrong missile). Cross fire is also

used to obtain flank shots, which are desirable; it increases the chance of a kill and assists in avoiding detection when the enemy is moving straight at the Dragon. Each Dragon engages a target at a diagonal to its position, with flank Dragons engaging targets on the opposite flank. As targets are destroyed, fire is shifted to the center of the enemy formation. (See A, Figure 3-25.)

(2) *Depth fire*. Depth fire is used when targets are exposed in depth. Dragons on one side engage the nearest targets, while Dragons on the other side engage the farthest targets. Fire is then shifted toward the center of the formation. This can be done by unit SOP or as specified in the section leader's order. (See B, Figure 3-25.)

(3) *Changing or concurrent fire patterns.* Fire patterns are changed or used concurrently with another fire pattern. This may be necessary when the enemy adjusts his formation after being engaged to ensure maximum coverage of an enemy formation. (See Figure 3-25.)

f. *Fire Commands.* Fire commands speed the execution of target engagement when unforeseen circumstances arise during engagements that are not covered by SOPs or the fire plans. Under normal circumstances, the few seconds available to the gunner to engage targets prevent his listening and reacting to a lengthy fire command sent by radio.

- *Alert:* Warns the gunner(s) of a fire mission.

Ž *Target description/location:* A brief description of the target location given either from a TRP or as direction and distance from the gunner.

- *Method of engagement:* Tell the gunner(s) how to engage a formation, cross or depth—front to rear or left to right.

Ž *Execution:* Command to fire.

g. *Emergency Fire Signals.* Radio communications can fail. Therefore, fire control is difficult. The use of

sectors of fire and alternate signals with pyrotechnics is often the only quick method available to control the fire of Dragon gunners. Units must establish SOPs and practice lost communications procedures.

h. *Range Cards.* It is often not practical to prepare range cards such as when moving from position to position to cover the movement of an advancing force or during retrograde operations. Then, the use of TRPs is the primary method to control the distribution of fire. Time permitting, range cards are prepared for primary, alternate, and supplementary positions, and they are designed to aid the gunner in engaging targets.

3-20. PLATOON FIRE PLAN

The fire plan (overlay and target list) is used by the company commander or platoon leader as a ready reference tool. It allows him to shift the fires of weapons distributed throughout the sector into an area. This can be done without moving to determine which weapons can fire into that area, which could be time-consuming and risky under fire. If a portion of the platoon sector is in danger, the platoon leader consults his fire plan to quickly determine which weapons can cover the threatened area and from which positions they can do so. He then directs (by radio, voice commands, or SOP signals) that fires be shifted

to the threatened area. He also includes instructions to move to alternate or supplementary positions. On the fire plan, TRPs outside the platoon's assigned sector of fire are included that can be covered by the platoon's weapons. This allows the platoon leader to quickly respond to calls for assistance from adjacent units.

a. A platoon defensive fire plan consists of a target list for indirect and antiarmor fires and an overlay drawn to scale, showing the platoon sector and the positions of the Dragons and machine guns.

b. The FPL or PDF location of major obstacles, mortar or artillery FPFs, sectors of fire for Dragons, and all TRPs that the platoon can cover are also shown on the overlay. Figure 3-26 is an example of a two-platoon fire plan.

NOTE: Refer to either FM 7-7, FM 7-7J, FM 7-8, or FM 7-10 for a detailed discussion of fire plans.

c. The platoon fire plan should be incorporated into the company FSO's fire support matrix. Once the fire plan is incorporated, FIST personnel can call for and adjust fire on enemy concentrations or call for FASCAM.

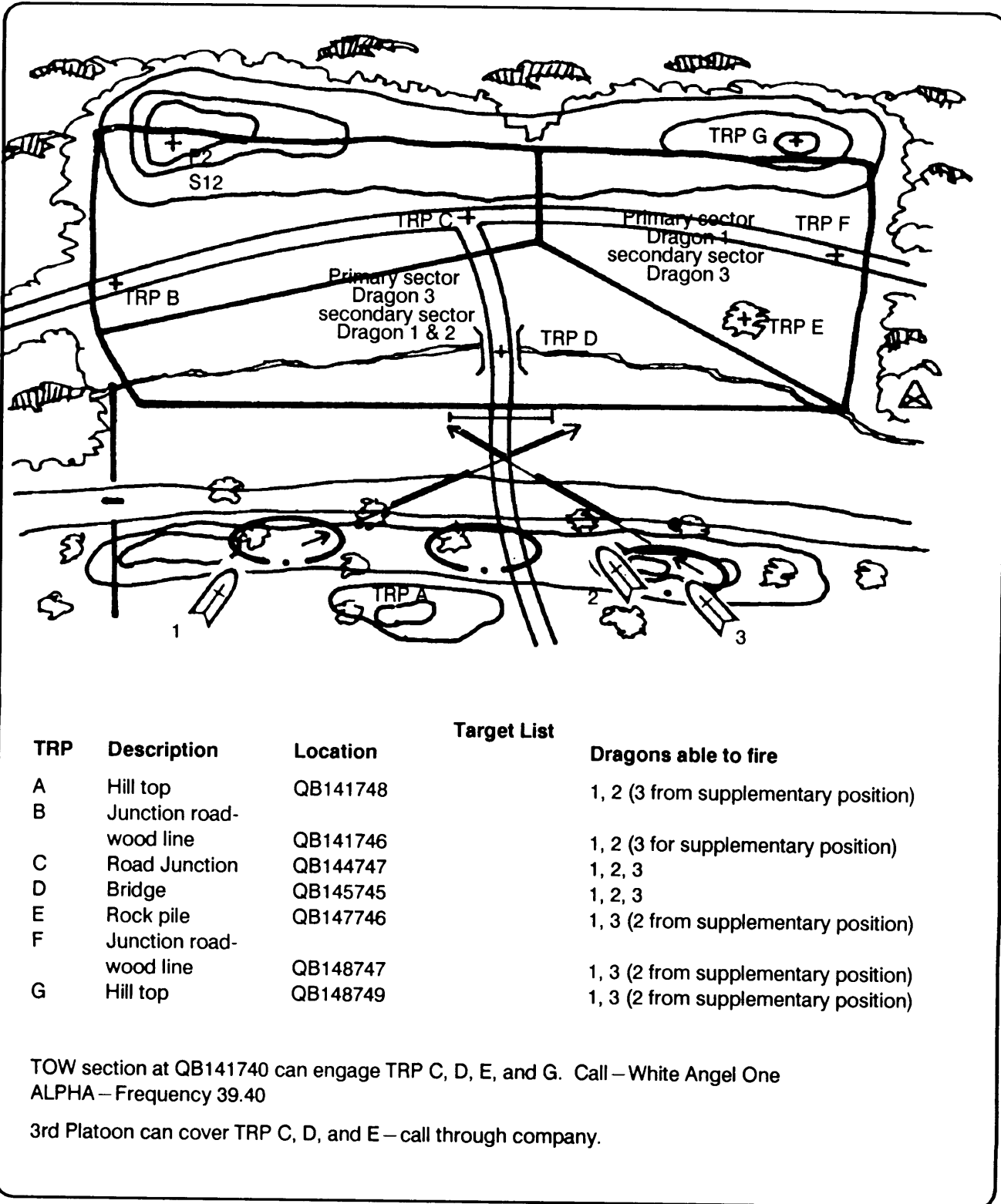

Figure 3-26. Example two-platoon fire plan.

3-21. ARMOR-KILLER TEAM

When a Dragon team is enlarged with added security personnel and a leader (command and control element) and given an independent mission; for example, an antiarmor ambush, falling in gaps at night, or during reduced visibility, it becomes an armor-killer team. Normally, an armor-killer team (with Dragon[s]) is a team or larger unit (squad-size or larger when mounted). This provides for enough personnel to carry the trackers and extra rounds, to provide supporting fire and local security, to maintain communications, and to control the team. (See Figure 3-27.)

a. Mission. The primary mission of an armor-killer team is to destroy enemy armor vehicles without becoming decisively engaged. They are also used to call for and adjust indirect fires and to report on enemy movements.

b. Employment. The company commander often directs his platoon leaders to place armor-killer teams throughout the battle area –

Ž To cover dead space.

Ž To add depth to the battle area.

- To gain flanking fire into armor avenues of approach.

- To ensure mutual support between platoons. (See Figure 3-28.)

They are also employed along armor avenues of approach at night and during other periods of reduced visibility (Figure 3-29) to replace less effective ATGM fires. Such armor-killer teams are often armed with Dragons and LAWS (M72s and AT4s).

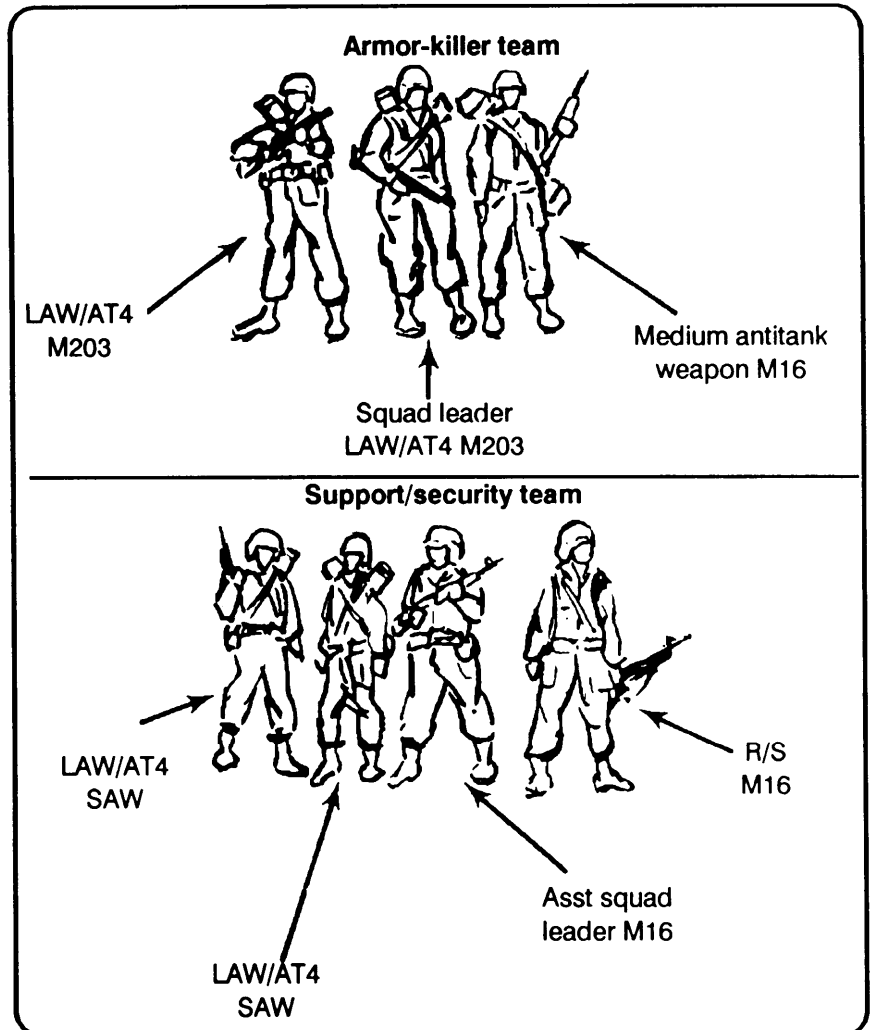

Figure 3-27. Example of an armor-killer team.

(1) The platoon’s Dragons are often positioned at locations different from those of the machine guns and rifle positions. Rifles and machine guns are positioned to protect the platoon’s sector from dismounted attacks. Dragons are positioned to fire into armor avenues of approach in the platoon or company sector.

(2) The platoon leader ensures that Dragon positions are provided with close-in security from dismounted

infantry attack and mounted armor attacks. He does this by–

(a) Employing armor-killer teams with Dragons if the best firing position is located where it cannot be supported by other platoon positions.

(b) Ensuring that LAWS (either AT4s and or M72s) are provided to the security elements to protect against close-in armored attacks.

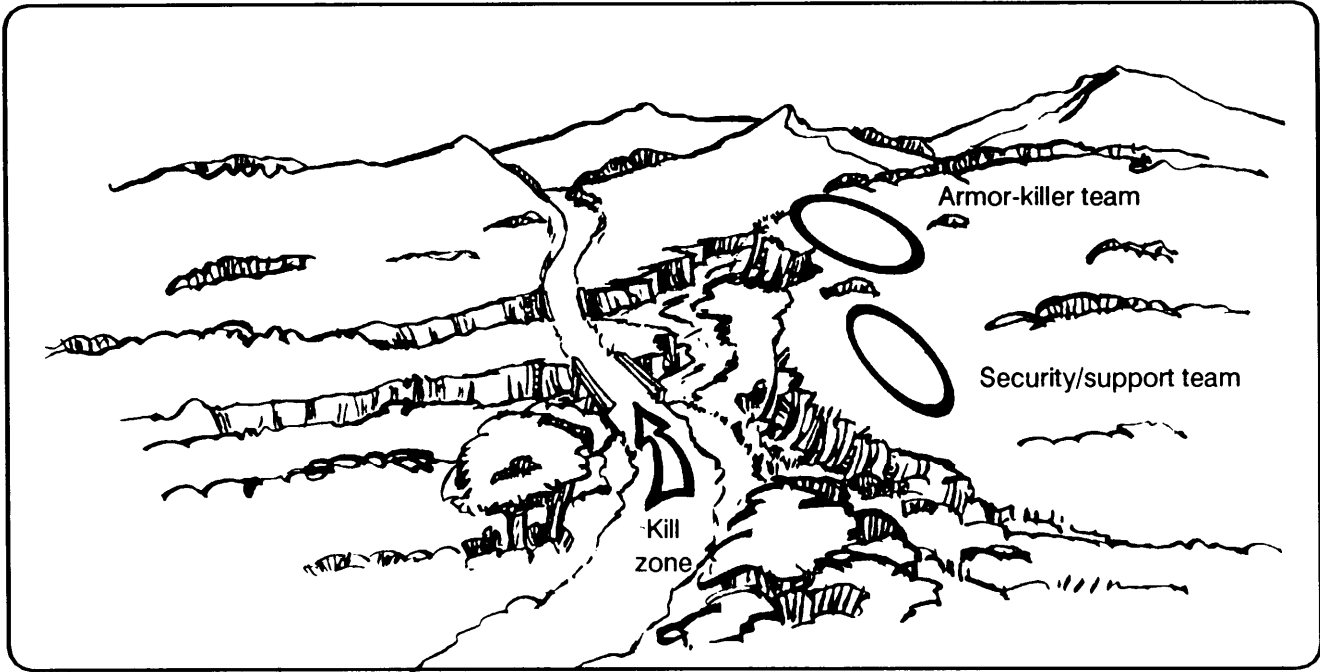

Figure 3-28. Employment along an armor avenue of approach.

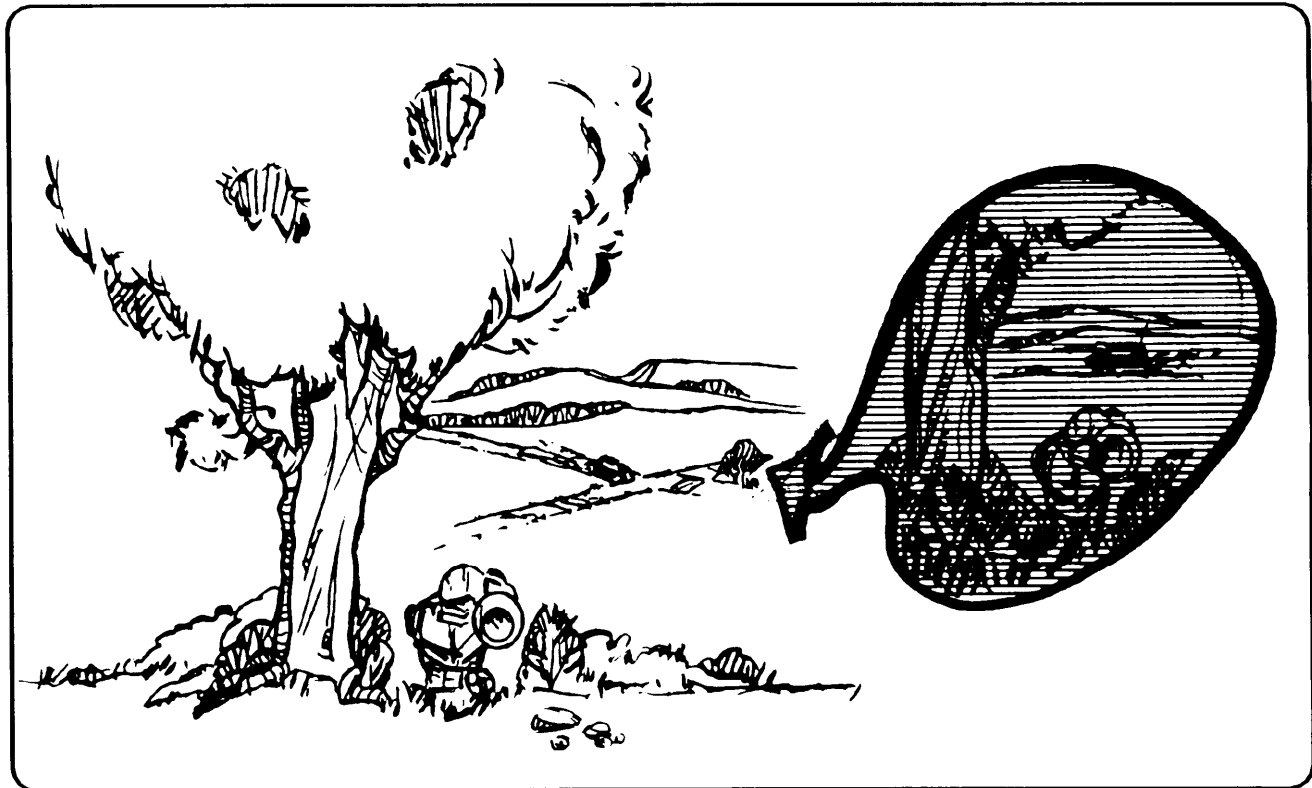

Figure 3-29. Employment during limited visibility.

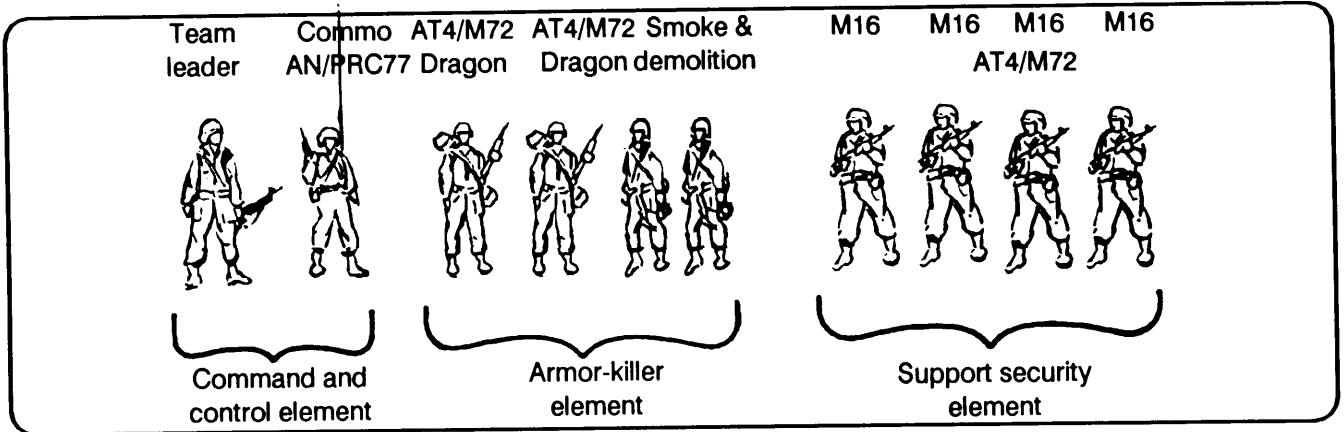

Figure 3-30. Squad-size armor-killer team.

(c) Positioning the Dragons close enough to the squad positions so that the squad provides protection

against ground attack for the gunner and team.

c. Composition. Armor-killer teams may be fire-team size or squad-size. (See Figure 3-30.)

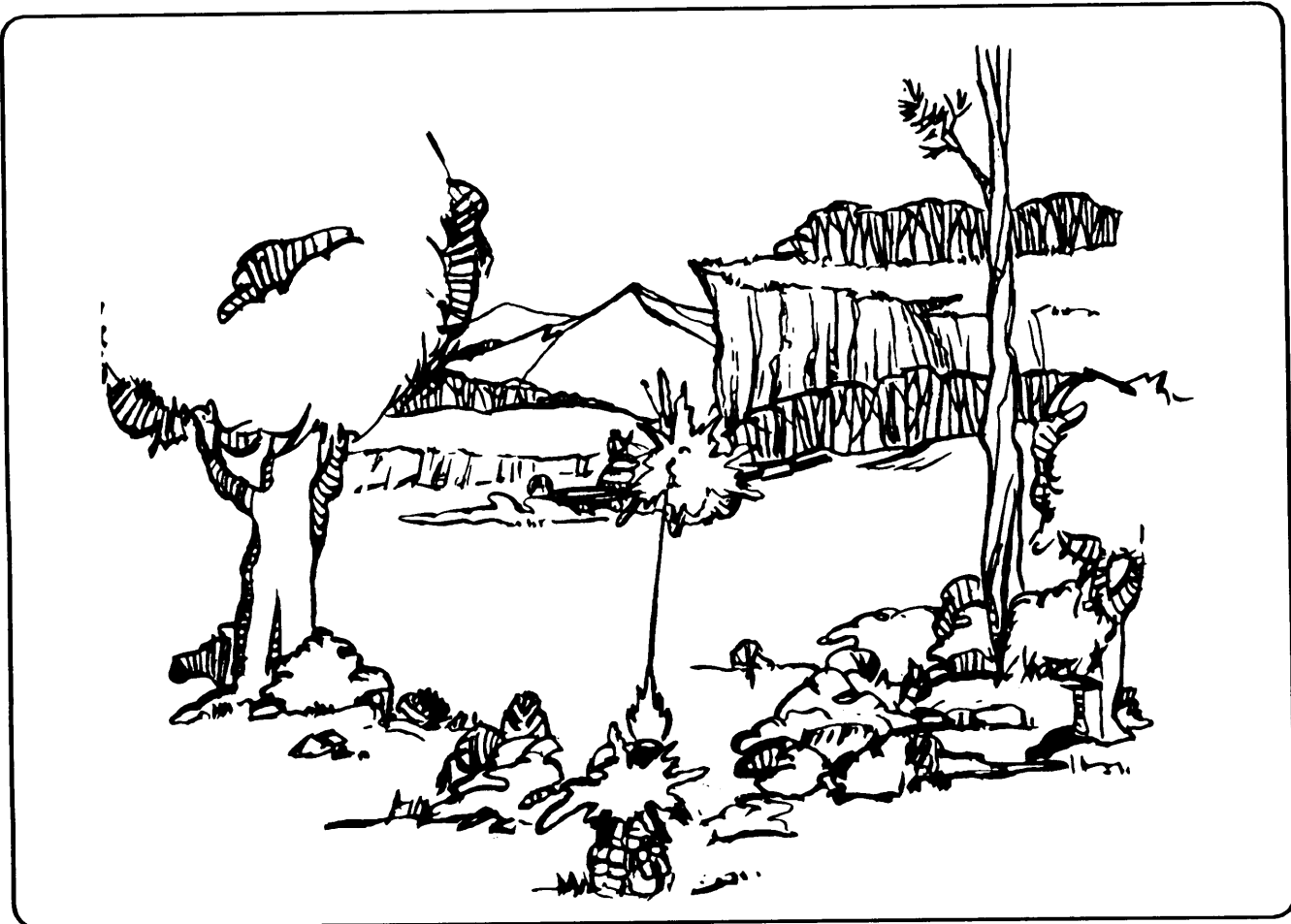

Figure 3-31. Positioning for flank shot.

d. Terrain. Normally, teams are employed on ambush positions that place a tank obstacle, such as a gully or swamp, between them and their target. Position the armor-killer team where the actual engagement does not put the team in danger of being destroyed by other enemy armored vehicles.

e. Engagement Techniques. Individual enemy armor vehicles are engaged when there is a high probability of hit or kill.

Armor-killer teams are armed with M72s and or AT4s when operating in areas with restricted vision, fields of fire (dense woods), and a mix of M72s, AT4s, and Dragons in areas with intermittent open spaces or LOS down a road. (See Figure 3-31.)

f. Control and Mobility. Teams should be under control of the commander who is responsible for the sector they are occupying. The Dragon section leader or team leader will be in control of his

element. He makes recommendations to the commander about employment and or deployment. Mobility of the armor killer-teams should be equal to or greater than the enemy's mobility. Mobility may be gained by the use of M113s or by well-planned routes for dismounted teams through terrain that restricts vehicular movement. (See Figure 3-32.) Teams may also be delivered into and extracted from their ambush positions by helicopter.

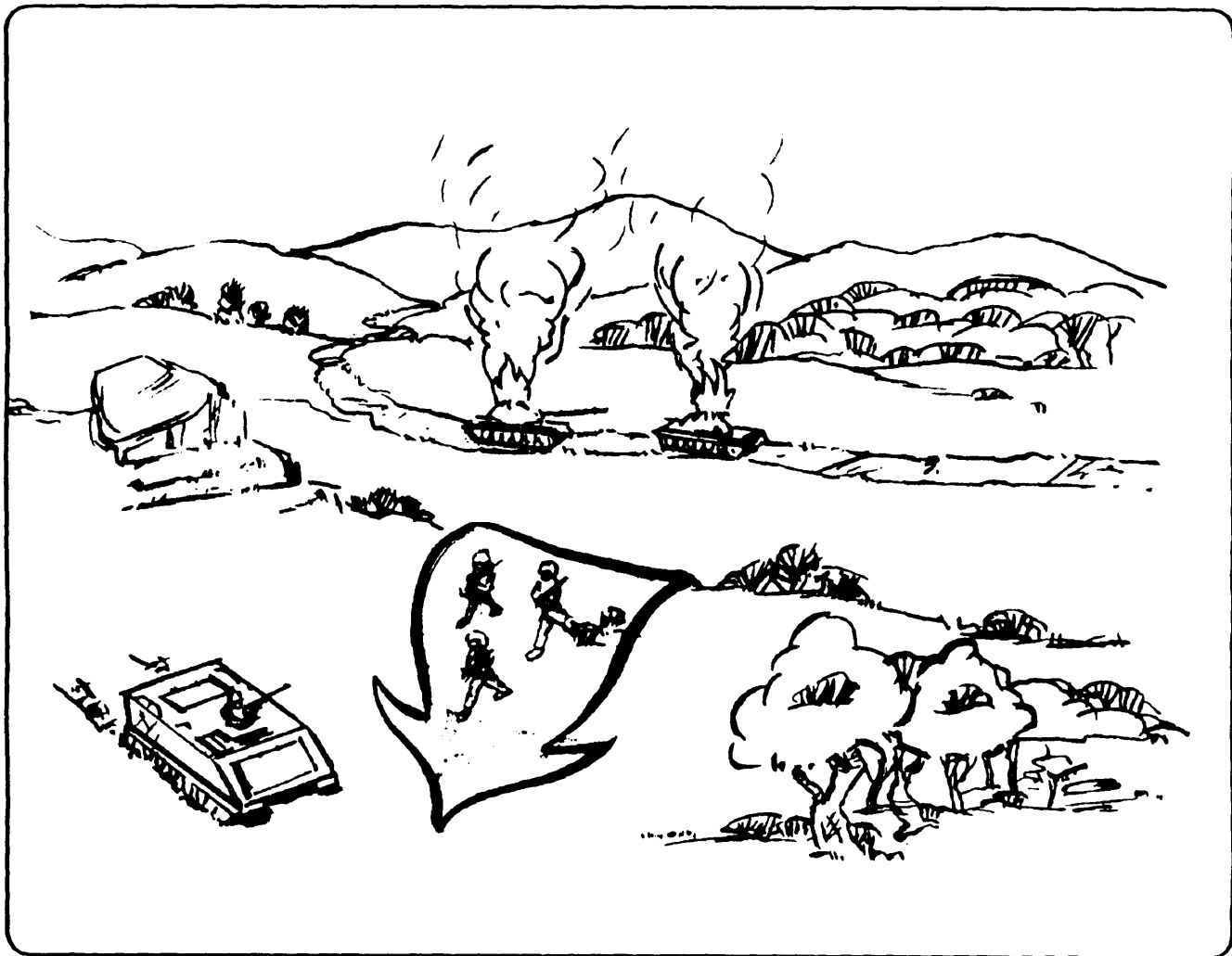

Figure 3-32. Example of mobility using an M113.

Section IV. EMPLOYMENT IN THE RETROGRADE

The primary consideration for the employment of Dragons in support of a retrograde operation against an armored enemy is to ensure antiarmor weapons are in a position to cover all movement. These

antiarmor weapons may be organic Dragons and M72s/AT4s or the antiarmor weapons of another unit. The techniques discussed in this section are intended only as a guide

to assist in correctly employing Dragons.

NOTE: Further instructions are outlined in either FM 7-7, FM 7-7J, FM 7-8, or FM 7-10 for your particular unit.

3-22. RETROGRADE OPERATIONS

All retrograde operations involve movement away from the enemy.

The platoon itself conducts two types of retrograde operations: delay

and withdrawal. Retirements are conducted as a part of a larger force.

3-23. DELAYING OPERATIONS

In a delay, a unit trades space for time. The intent is to slow the enemy, to cause enemy casualties, and, if possible, to stop him without becoming decisively engaged. This is done by defending, disengaging, moving, and defending again. Platoons do not conduct delays alone but fight as part of their company in a delay. The delay positions are organized like the defense, except that it may be necessary to extend frontages and reduce the depth of the position.

a. Infantry. When dismounted infantry elements delay against an enemy with an armored capability, they use the tactics of defense and withdrawal to effect delay. At platoon level, there are some differences in the selection of delay positions and defense positions. The presence of covered and concealed routes of withdrawal take on added importance to the delay force. When delaying over restricted terrain, an infantry platoon is often directed to set up armor-killer ambushes. Dragons

should be emplaced where they can slow or stop advancing armored vehicles by blocking roads or avenues of approach. The Dragons withdraw by bounds, covering the withdrawing force and each other.

b. Mechanized Infantry. The employment of Dragons by the mechanized infantry platoon depends on the amount of available tank and TOW support. Without such support, the mechanized platoon, like the dismounted platoon, uses the tactics of defense and withdrawal; or, terrain permitting, breaks down into armor-killer teams. The Dragon is then the platoon's primary antiarmor weapon. When the mechanized unit has TOWs and tanks attached or when it works as a part of a combined-arms team, the Dragon becomes a secondary weapon—

- To support the fires of tanks and TOWs.
- To cover secondary armor avenues of approach.

- To provide an antiarmor capability to OPs and or LPs.

The following applies to the employment of Dragon in the delay.

(1) In the delay, targets are normally engaged at the maximum effective range (METT-T dependent); therefore, delay positions are normally on or near the topographical crest of a hill. This location takes advantage of long-range observation and fields of fire, and immediate masking of enemy observation and direct fires when the withdrawal from the position is ordered.

(2) As enemy armor comes within effective range according to METT-T, Dragon gunners engage the leading element at maximum range in an attempt to force the armor units to deploy or mass on roads and trails. If the enemy allows his force to mass, the delaying force calls for all available means to destroy him in this weak position. If not destroyed, the enemy is forced into the time-consuming task of

deploying his force to attack the delay position.

(3) The extended frontages, normal with the delay, require the leaders of the company to give careful consideration to positioning Dragon weapons to cover armored avenues of approach into their delay position. Mutual support between Dragons in all of the platoons will be more difficult to achieve. It requires added emphasis by the company commander to ensure that all antiarmor fires are coordinated to achieve maximum delay.

(4) When maximum delay is achieved, Dragon weapons are withdrawn with their squads for movement to the new delay position.

When enemy armor forces or distance between delay positions are considerable, armor-killer teams may be formed with Dragon weapons. The armor-killer teams are positioned in ambushes between delay positions to delay the enemy's advance.

(5) Planning considerations include reconnaissance, prestocking or pre-positioning of Dragon ammunition, and construction of obstacles.

(a) Reconnaissance. Leaders must give special attention to choosing Dragon positions along the routes of withdrawal and at the next delay position during their reconnaissance. This is critical

because of the rapid movement in the delay and the possibility that Dragons may be employed between delay positions.

(b) Dragon ammunition. Because of the high volume of ammunition use in delay operations, plans must be made to increase the number of rounds available to the Dragon gunner. It may be necessary to dedicate a vehicle to carry extra Dragon missiles.

(c) Obstacles. As in defensive operations, Dragon fires are combined with natural and man-made obstacles. In the delay, this becomes even more important because of the extended frontages normal in the delay.

3-24 WITHDRAWAL

In a withdrawal, a company disengages from the enemy and repositions for another mission. That mission may be to delay the enemy, to defend another position, or to attack someplace else. If a withdrawal is called for, it must be well planned.

a. Types of Withdrawal. There are two types of withdrawal: under enemy pressure and not under enemy pressure.

(1) *Conduct of withdrawal under enemy pressure.* This is the most difficult and least desired method (Figure 3-33). In this type of withdrawal, the platoon, employing fire and maneuver, literally fights its way back from the enemy. The use of Dragons to support this type of maneuver is slightly different from employment in offensive maneuver. There is a need to have Dragons with both

covering and maneuvering elements to ensure continuous antiarmor coverage.

(a) As in the delay, after withdrawal from the position, the platoon moves to and occupies either a delay position, a defense position, or an assembly area to prepare for future operations. The withdrawal under enemy pressure is the most dangerous and difficult to control of all tactical maneuvers. It is characterized by the forward elements fighting as they withdraw.

(b) When conducting withdrawals, the control of the Dragon's fires is usually divided between the platoon leader and the PSG. The platoon is normally broken into two elements—part of the platoon covering and part moving. The platoon leader controls one element, the PSG the other. Within each

element, Dragons are normally directly controlled by the platoon leader and PSG.

- **Length of bound.** When bounding back using maneuver and providing organic support (Dragons, M72s and or AT4s, and machine guns fire as the only supporting weapons), the length of the bound cannot exceed the effective range of these weapons on the terrain over which the withdrawal occurs. If given outside antiarmor fire support, the distance may be increased.
- **Use of artillery to cover a withdrawal.** Advances of the enemy's armor cannot be stopped by artillery fires, even though such fires slow their rate of movement to a large extent. Use of smoke often allows disengagement from an

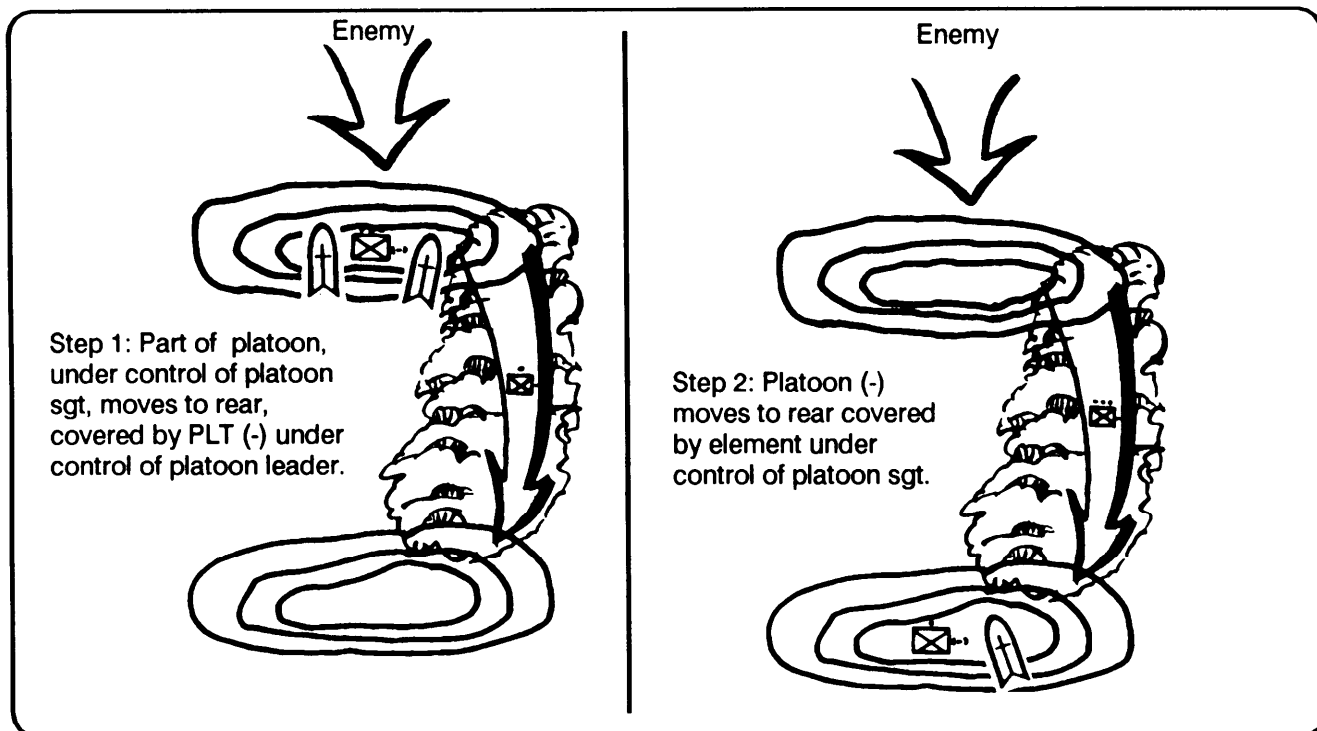

Figure 3-33. Example of withdrawal under enemy pressure.

armored enemy because smoke –

- Slows down the movement of tanks.
- Reduces the sighting range of tank gunners.
- Increases the vulnerability of tanks to armor-killer teams (M72s, AT4s, Dragon).
- Does not hamper the mobility of the withdrawing infantry (as could regular artillery fire).

(2) *Withdrawal not under enemy pressure.* A withdrawal not under pressure (Figure 3-34) is conducted with speed, secrecy, and deception. It is best done at night or during other reduced visibility (fog, snow, rain, or smoke). Usually, all elements move to the rear at the

same time. The company leaves a security force to cover the withdrawal by deception and maneuver, when required. The security force normally consists of a squad from each platoon and no more than half the company supporting weapons. The commander designates a security force commander, normally the company XO or a platoon leader. The Dragons left behind should be those in the best position to cover the armor avenues of approach.

(3) *Sequence of withdrawal.* For Dragon teams, the sequence of withdrawal depends on the amount of antiarmor support available to the platoon and the threat. The Dragon teams may withdraw first if facing a limited armor threat or if heavily supported by tanks and TOWs. If facing a strong armored threat and

unsupported by other antiarmor weapons, the Dragon teams are probably the last element to withdraw. If tanks are attached, tanks are normally part of the security force. When the withdrawal of the security force is ordered, Dragons are withdrawn with their squads.

b. *Selection and Preparation of the Next Subsequent Position.* During the company commander's reconnaissance, he selects assembly areas for the platoons. Platoon advance parties should select Dragon firing positions at the next subsequent position. These positions will be confirmed and adjusted, as necessary, by the platoon leader after the arrival of the platoon's main body at the position.

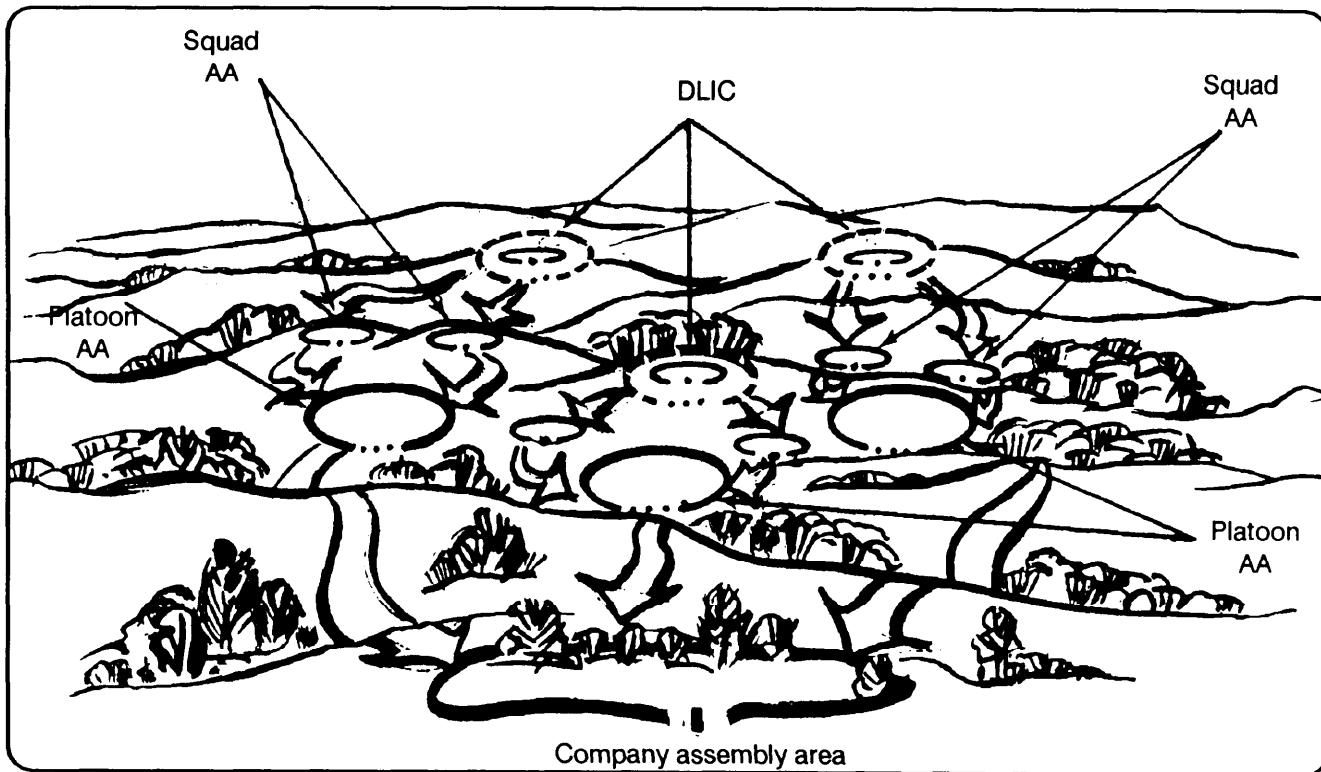

Figure 3-34. Withdrawal not under pressure.

Section V. EMPLOYMENT IN THE OFFENSE

In the attack, the Dragon is used to provide antiarmor fire to assist the platoon's advance and to protect it

from armored counterattacks. In the absence of armored targets, the Dragon can be used to eliminate

enemy crew-served weapons, fortifications, and other suitable hard targets.

3-25. MOVEMENT TO CONTACT

The dismounted infantry platoon moves to contact, using the techniques outlined in FM 7-8. The mechanized platoon uses the techniques outlined in FM 7-7, FM 7-7J, and FM 7-10. In both cases, the Dragons are employed to provide protection and support for all elements of the platoon against antiarmor threat.

a. Dismounted Infantry Platoon. When moving to contact using

traveling overwatch or bounding overwatch techniques, the platoon leader organizes his platoon to provide for centralized Dragon control (if assigned) and maximum flexibility. The tactical situation dictates employment of the Dragons within the platoon. The primary consideration to determine which squad the Dragon will be assigned for movement is the availability of fields of fire and the armor threat.

(1) The bulk of the Dragon rounds combined with the minimum effective range (65 meters) of the weapon and the exposure of the gunner during firing, limit the ability of Dragon gunners and teams to participate in a maneuver or effectively use the individual movement techniques necessary to the survival of the assaulting riflemen.

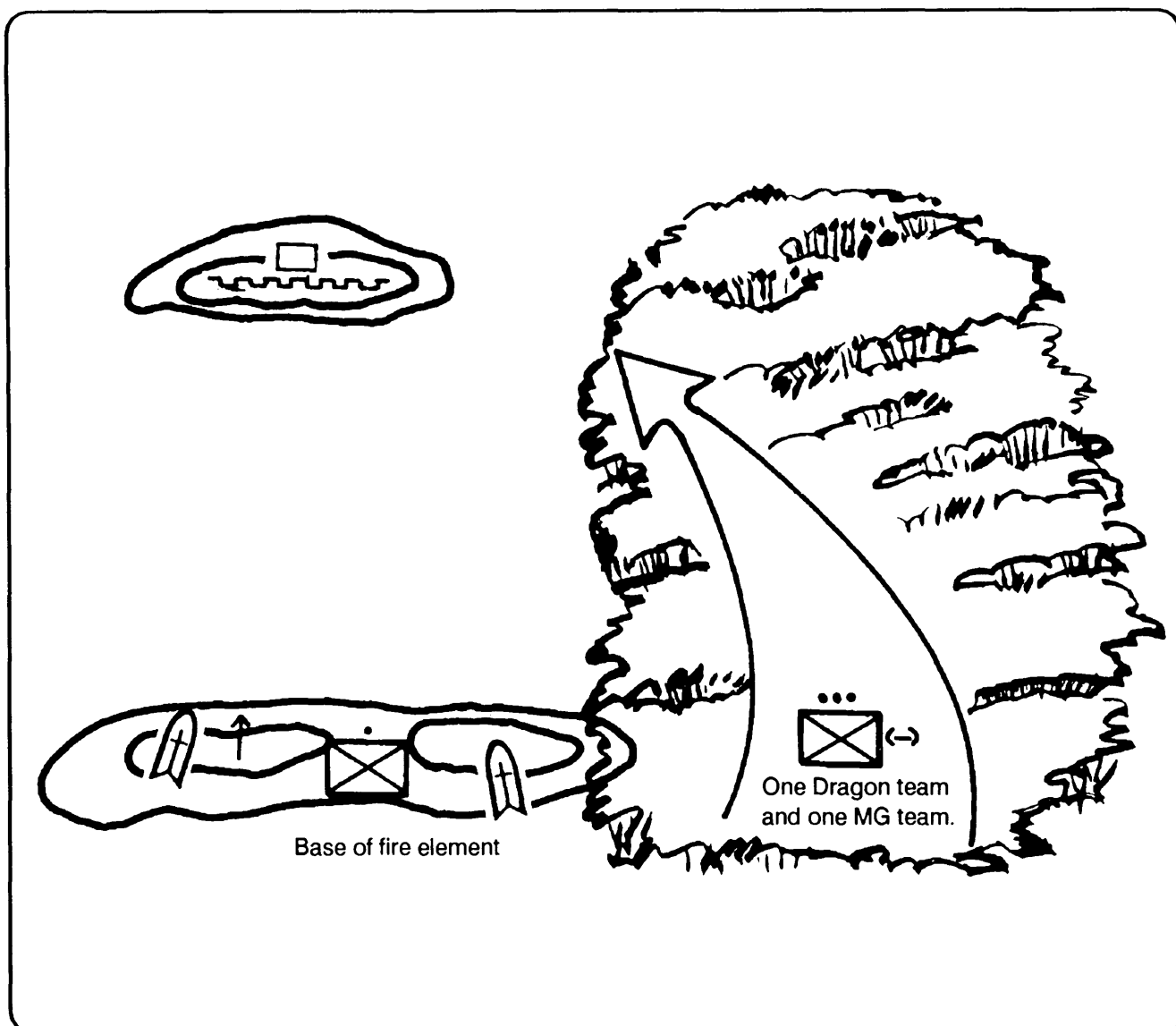

Figure 3-35. Employment of the base of fire.

(2) The dismounted infantry platoon uses Dragons and machine guns as the main elements of its base of fire. A rifle squad is often assigned as the base of fire, which the PSG normally controls. The PSG coordinates the supporting fires with the platoon leader, using radio and visual communications. The base of fire can be employed from a stationary position (Figure 3-35) or moved by

bounds behind the maneuver element. If required to engage a target of opportunity, the Dragon gunner selects the best covered and concealed position.

NOTE: When a stationary base of fire is used, one Dragon normally moves with the platoon leader to provide immediate protective fires for the maneuver element.

b. Mechanized Infantry Platoon. The mechanized infantry platoon employs its Dragons differently than the dismounted infantry platoon, because the mechanized platoon has a greater capacity to carry Dragon rounds and the vehicle presents more of a target to the enemy. The mechanized platoon usually employs a Dragon with its leading squad to increase the

squad's overwatch capability. Also, the platoon leader normally maintains only one Dragon directly under his control.

(1) When the mechanized infantry platoon attacks without tank support, most of the employed Dragons are collocated with the vehicles to provide the base of fire. They are controlled by the PSG. The

number of Dragons employed with the base-of-fire element is determined by the nature of the enemy resistance. The exact method used is based on the need for supporting fires. As with the dismounted infantry platoon, one Dragon may accompany the maneuver element.

(2) When the mechanized platoon attacks as part of a combined-arms team, the primary antiarmor weapons are TOWs and tanks since there is less of a requirement for employment of Dragons. Therefore, the advantages of employing the Dragon must be carefully weighed against the reduction in rifle strength as a result of this weapon employment.

3-26. CONDUCT OF THE DAY ATTACK

The following techniques of a day attack govern the employment of the Dragon in the offense.

a. Movement from the assembly area to the LD. The Dragon may precede the rest of the platoon by moving to overwatch positions on or near the LD.

(1) The nature of the threat on or near the objective and along the route of attack; that is, known or suspected locations of suitable targets, and enemy armor approaches into the route of advance.

(2) Observation and fields of fire from the LD over the route(s) to the objective.

(3) The availability of firing positions that provide good observation and fields of fire along the route(s) to the objective.

(4) The availability of antiarmor fire support from other sources.

b. Movement from the LD to the assault position. The leader and gunners watch the progress of the maneuver element, shooting targets that threaten it. The leader

anticipates the masking of friendly fires and displaces the weapons one at a time. When the weapons are separated, each crew may displace under control of its gunner when its fire is masked or when it can no longer support the movement. The displacement of all weapons in the fire support element must be timed so that the platoon has ongoing fire support.

(1) If the LD is close to the assault position or the initial objective and good firing positions are available, some Dragons may occupy positions on or near the LD.

(2) Where the LD is too far from the assault position or objective or when suitable firing positions do not exist, the Dragon gunners should accompany the maneuvering elements across the LD until the mission is accomplished. In mechanized units, Dragons can provide covering fire from the dismount point. When centrally controlled, Dragons normally displace by bounds to ensure continuous overwatch of the advance (Figure 3-36).

c. Movement from the assault position to the objective. As the platoon nears the assault position, the fire element maintains a rate of fire to suppress the enemy. As the fire of the platoon fire element is masked, the platoon leader shifts fires or displaces the weapons. The fire element is quickly moved to positions for consolidation, covering likely armor approaches into the area to repel counterattack.

(1) During the assault, the Dragons are in position to best assist the advance of the elements. They are employed as far forward as possible, consistent with their ability to provide accurate fire during the assault. Some Dragons may be employed in an overwatch role; however, one or more should accompany the assaulting element to provide ongoing long-range fire beyond the objective.

(2) Dragons employed in an overwatch role are employed with a team to provide communications and security. The platoon leader positions gunners in the assault element where he can best control them and direct their fires.

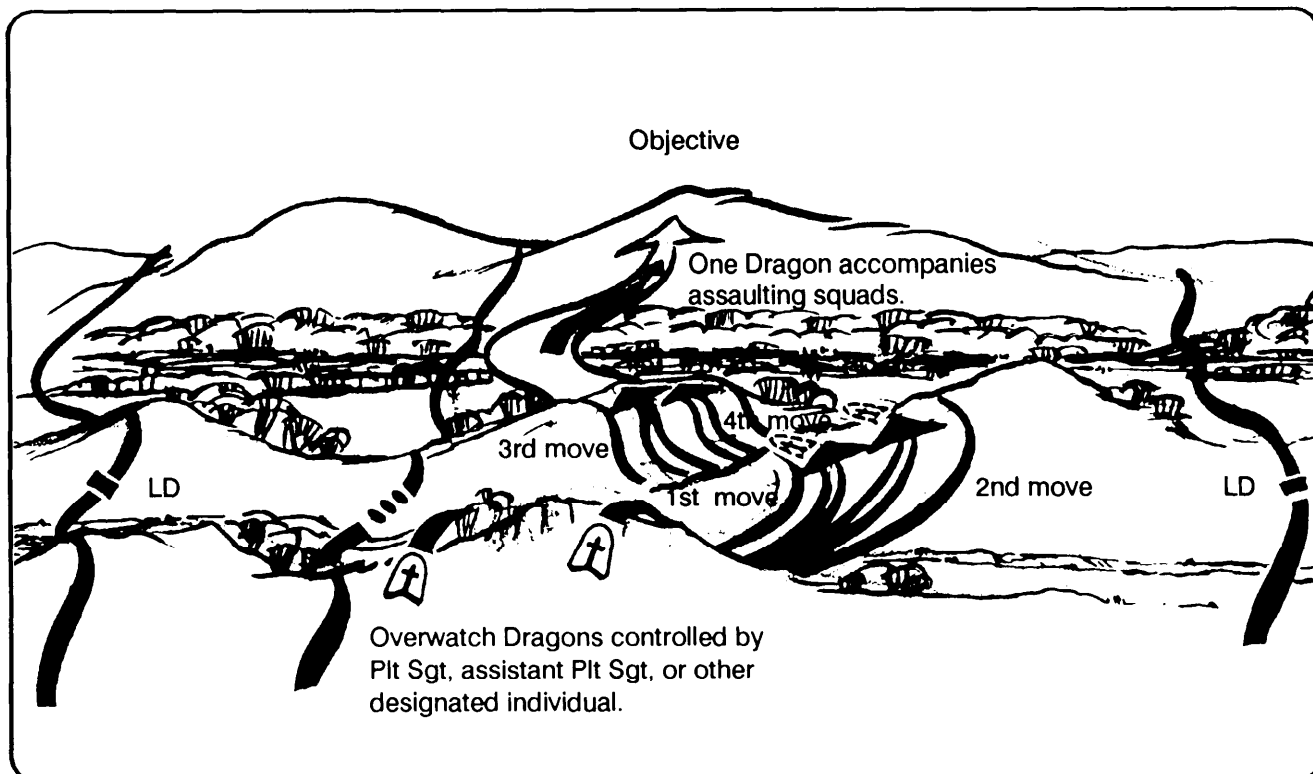

Figure 3-36. Overwatch Dragons in the attack.

3-27. CONDUCT OF THE NIGHT ATTACK

The AN/TAS-5 allows the Dragon to be used during reduced visibility the same as during normal visibility. Under artificial illumination, the techniques of daylight operations also apply. This paragraph discusses a nonilluminated, nonsupported night attack by stealth.

a. Night combat is characterized by—

- (1) A decrease in the ability to place well-aimed fire on the enemy.
- (2) An increase in the importance of close combat, volume of fire, and by the fires of certain weapons laid on targets during daylight.
- (3) Difficulty of movement.

(4) Difficulty in maintaining control, direction, and contact.

Despite these problems, the night attack gives the attacker a psychological advantage by magnifying the defender's doubts and fears of the unknown.

b. The conduct of the attack by stealth requires that the attacking elements reach the probable line of deployment without being discovered. Before this, the unit commander can call for illumination and planned supporting fires. If he does call for illumination, the attack then continues, using the tactics and techniques for a daylight attack.

c. The attacking units move from the assembly area in a column

formation. The Dragon gunners are in the platoon formation where they can best deploy into the assault formation or can separate themselves from the assaulting element if their mission is to support by fire.

d. Firing positions for support weapons forward of the LD are chosen during daylight. Characteristics and limitations of the night tracker in regard to range are carefully considered when choosing these positions. Signature effects of the missile must also be carefully considered; the Dragon missile leaves a distinctive launch signature and flight path at night because of the action of the side thrusters. Therefore, quick displacement to

selected alternate firing positions prevents accurate counterfire from the enemy.

c. If it is not possible to select firing positions during daylight, Dragon gunners should accompany the maneuver element, unless the nature

of terrain, such as desert, provides a clear flight path for the missile.

f. Dragons employed in the assault element are employed the same as during daylight; the command to fire is given by the platoon leader. If the attack is discovered, gunners provide accurate fire support on the

platoon leader's command. Maximum use should be made for other antiarmor weapons to engage close-in targets to prevent unnecessary identification of Dragon positions due to launch signature cue.

3-28. CONSOLIDATION AND REORGANIZATION

Immediately after seizing the objective, the Dragon gunners are displaced to positions that afford long-range fires beyond the objective. This provides for antiarmor defense in depth and

covers the most likely avenues of armor approach into the position. The use of guides to direct those gunners displacing from overwatch positions into new positions speeds the operation. Reorganization is an

ongoing process; however, it is given special emphasis on seizure of the objective. Dragon gunners are assigned positions and defensive sectors, and they begin preparing for all-round antiarmor defense.

OPERATION AND FUNCTIONS

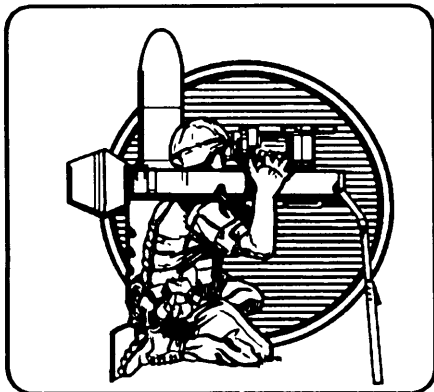

This chapter discusses normal operation and function procedures for the Dragon in the man-portable mode. (For a detailed discussion on the operation of Dragon support equipment, refer to TM 9-1425-484-10.)

4-1. INSPECTION

Inspection of the Dragon by the gunner is limited to visual inspection for physical damage. The inspections and checks are performed by the gunner before placing the Dragon into operation. During offensive operations, they are performed before leaving the

assembly area. During defensive operations, they are performed as part of the gunner's fighting position preparation.

NOTE: The gunner should use TM 9-1425-484-10 to perform PMCS.

- a. Inspection of the day tracker.
- b. Inspection of the night tracker.
- c. Inspection of the round of ammunition.

4-2. CARRYING POSITIONS

The Dragon can be carried using either the long-distance carry or the short-distance carry.

a. **Long-Distance Carry.** The Dragon gunner normally carries the round and tracker separately. This is especially true for long-distance moves such as road marches or

cross-country travel or when contact is not likely. Carrying options 1, 2, and 3 in Figure 4-1 are used for long-distance travel.

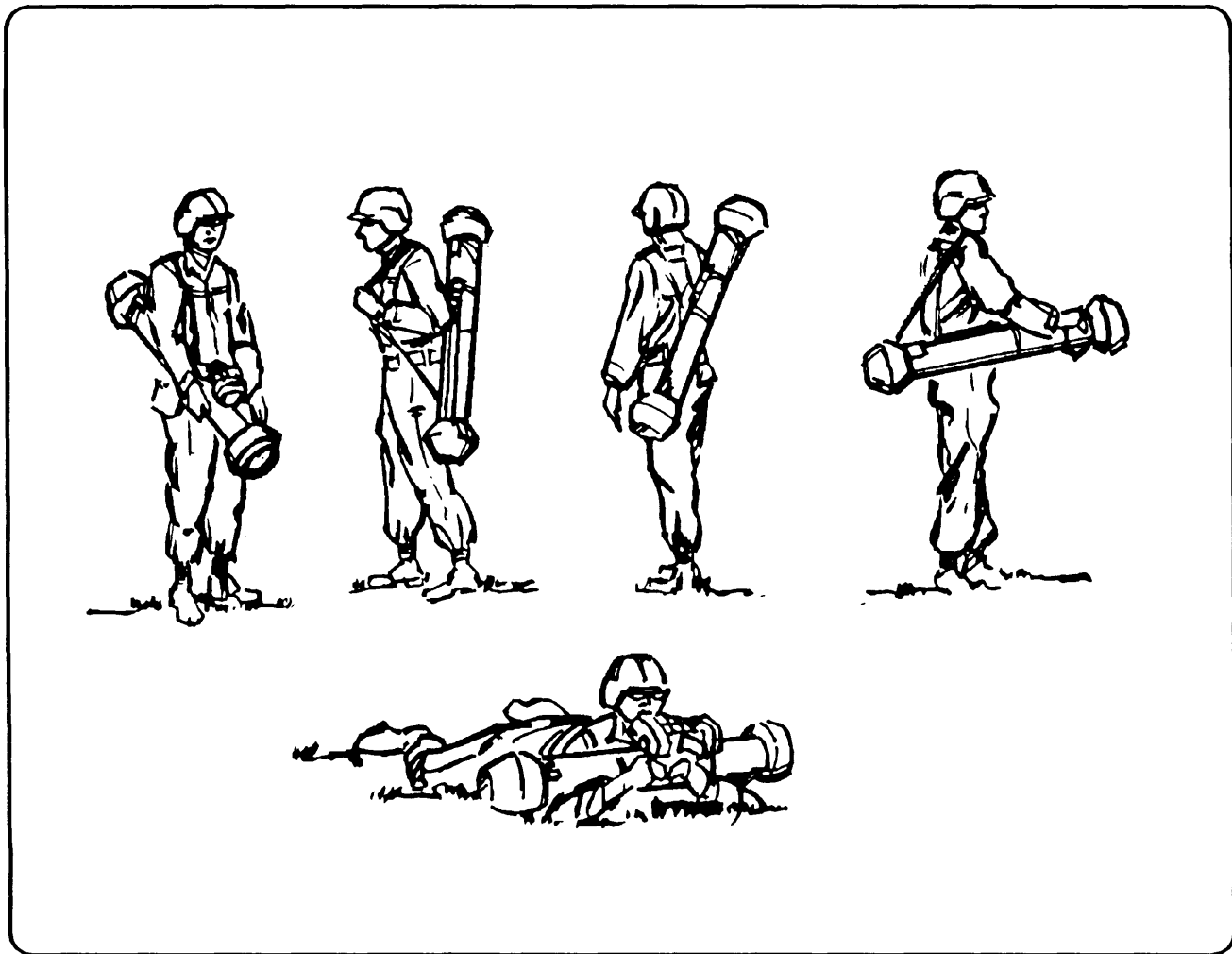

Figure 4-1. Dragon carrying positions.

b. **Short-Distance Carry.** The gunner can carry the Dragon with the tracker mated to the round for short distances. When using this type of carry, the gunner must keep the forward protective shock absorber

lens covers in place until the use of the weapon is anticipated. The protective lens covers prevent possible damage to the tracker lens and keep foreign objects out of the launcher. Carrying options 4 and 5

shown in Figure 4-1 can be used with the round and tracker mated. These carrying options should be used only when firing is likely, because the weapon system is in a ready-to-fire configuration.

4-3. PREPARATION OF THE ROUND FOR FIRING

Improper or careless handling of the round can damage the components and cause the missile to malfunction when launched. If there is any reason to believe the missile has been

damaged, the round must be returned to the responsible ammunition personnel for inspection and disposition.

NOTE: If the night tracker is to be used, a before-operations check must be conducted IAW TM 9-1425-484-10.

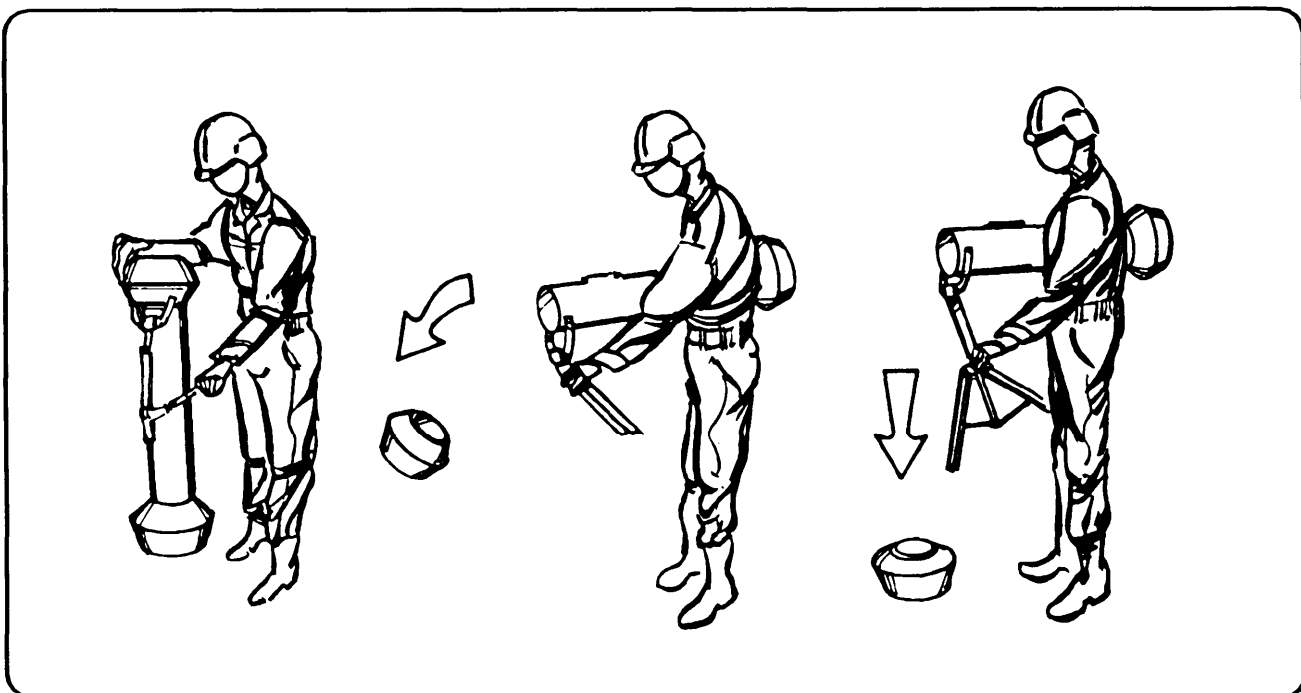

Figure 4-2. Releasing the bipod.

a. **Releasing the Bipod.** Unsnap the biped retaining strap (A, Figure 4-2). Push the biped forward until resistance is met. Then, snap off the forward shock absorber. Ensure that the desiccant bag, attached to the forward shock absorber, is not lodged in the launch tube (B, Figure 4-2). While still holding the round, depress the biped friction lock. Push the biped legs downward to number 4 or 5, then release the friction lock (C, Figure 4-2).

b. **Selecting a Firing Position.** A firing position is selected that best meets the situation, but for training, use the sitting position. (See paragraph 4-4.) Any one of the four positions may be used: sitting, kneeling, standing supported, or prone.

CAUTION: Do not lift the tracker using the shock absorbers as handles. They might tear off.

c. **Removing the Tracker (Day or Night) From the Carrying Bag or Rucksack.** Open the carrying bag or rucksack. Grasp the tracker by the telescope barrel or by the trigger mechanism and remove the tracker. Remove the connector cover from the electrical connector on the tracker. Secure the cover to the hook-pile tape on the forward shock absorber. Remove the connector cover from the round.

CAUTION: Do not touch the lenses. They can be damaged by touching with the fingers.

d. **Removing the Lens Cover.** Secure it on top of the forward shock absorber. Make a visual inspection of the lenses for damage or obstruction (Figure 4-3).

NOTE: If using the night tracker, make sure the ACTUATOR switch is in the ON position.

WARNING: Be careful not to press the safety and trigger while mating the tracker to the round.

e. **Mating the Tracker (Day or Night) to the Round.** Assume the firing position and put the round on the shoulder. Place the tracker guide pins in the slots of the tracker bracket guide rails (Figure 4-4). (For illustration, the day tracker is used. However, the procedure is the same as for the night tracker.) Slide the tracker firmly to the rear. Use both hands, until the spring clip locks the guide pin in place (Figure 4-5). If the tracker does not mate, notify your squad or section leader.

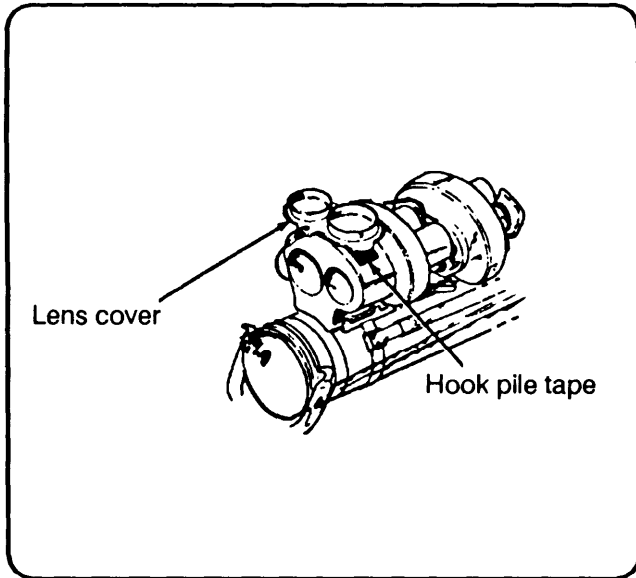

Figure 4-3. Cover secured to forward shock absorber.

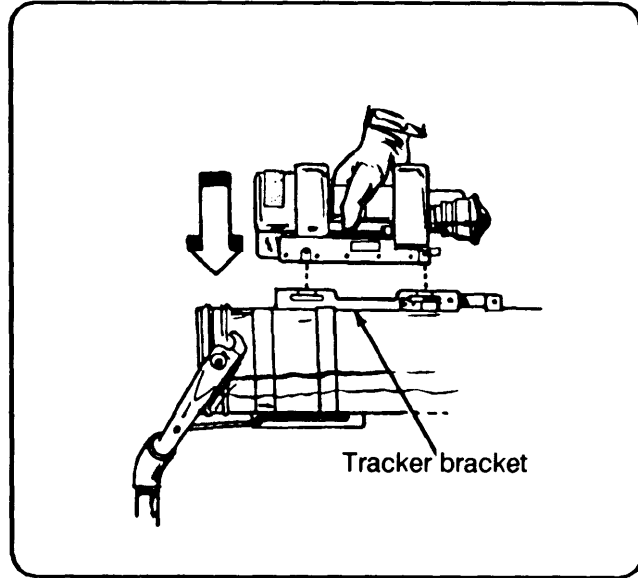

Figure 4-4. Aligning the day tracker guide pins.

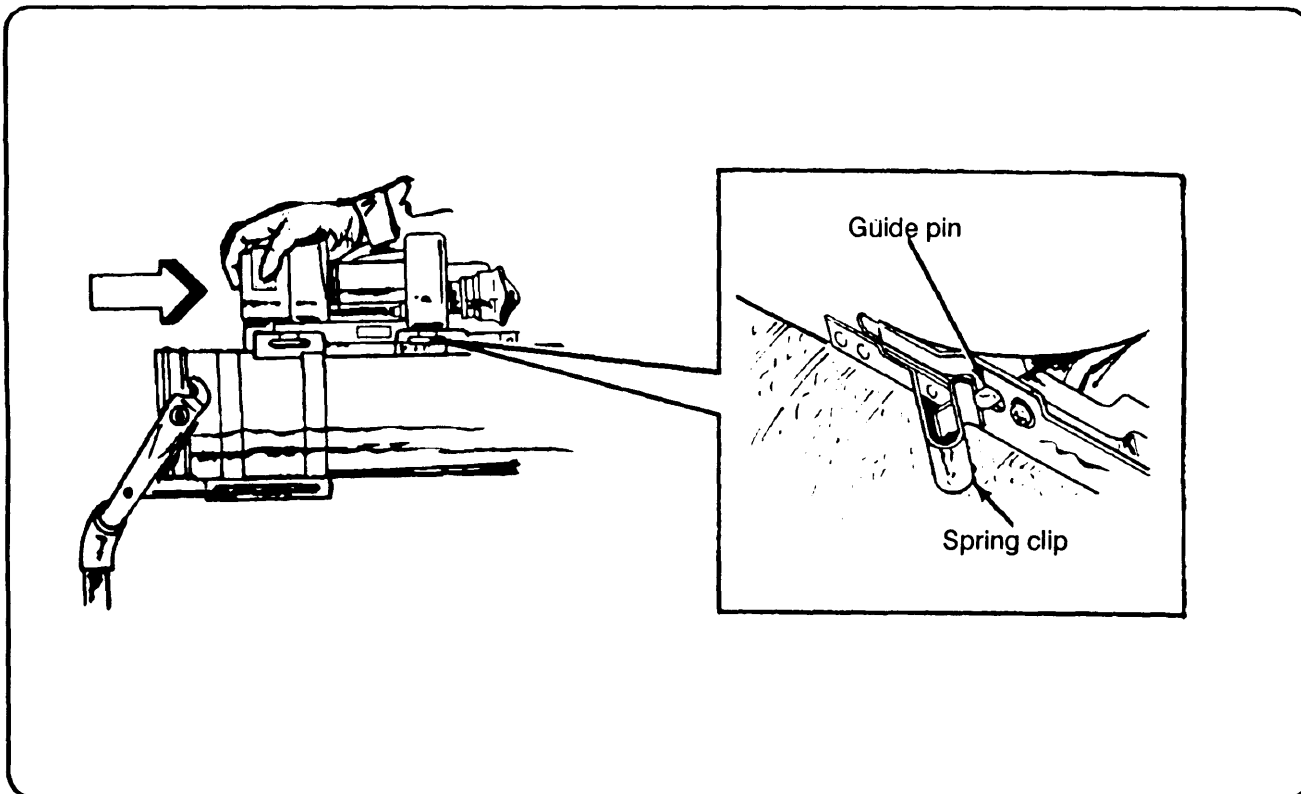

Figure 4-5. Seating the day tracker on the round.

f. **Adjusting for Height and a Level Sight Picture.** Look through the

sight to see if the sight picture is level. Adjust the biped friction lock and

the foot adjust to obtain a level sight picture (Figure 4-6).

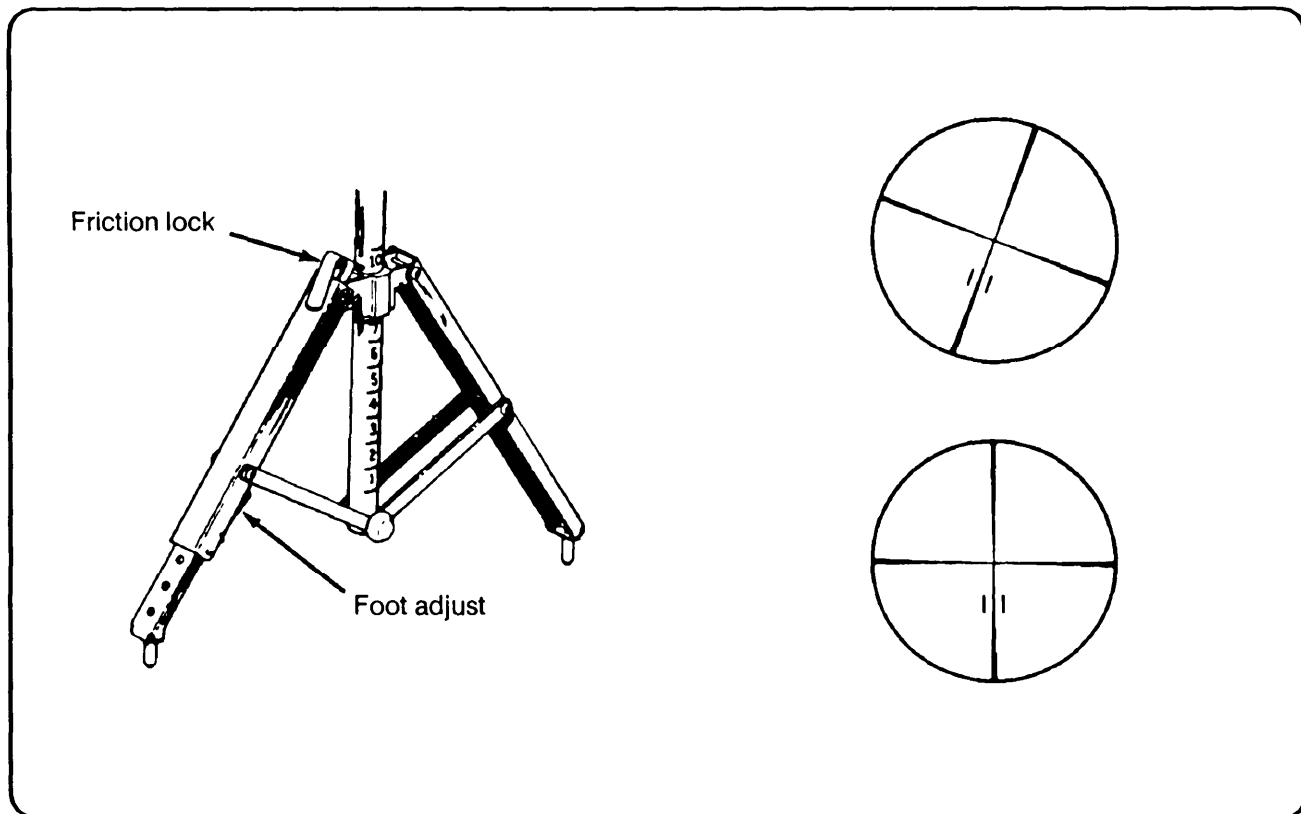

Figure 4-6. Leveling the sight picture.

NOTE: Failure to have a level sight picture (plus or minus 6 degrees) results in the missile

receiving bad commands from the tracker. The missile will be

erratic and impact on the ground.

4-4. FIRING POSITIONS

The Dragon can be fired from any one of the four basic firing positions: sitting, standing supported, kneeling, or prone. A modified

sitting or standing supported position can be used when the M175 mount is mounted on the machine gun tripods, M3 or M122. A detailed

description of these firing positions can be found in Chapter 7.

4-5. TARGET ACQUISITION AND EVALUATION

After the gunner acquires his firing position, he sights through the tracker to acquire the target (Figure 4-7). The target must be evaluated

to determine whether or not it is within range and engageable. The gunner adjusts his sight picture (by moving the launcher) to place the

target within the stadia lines. (See Chapter 3.)

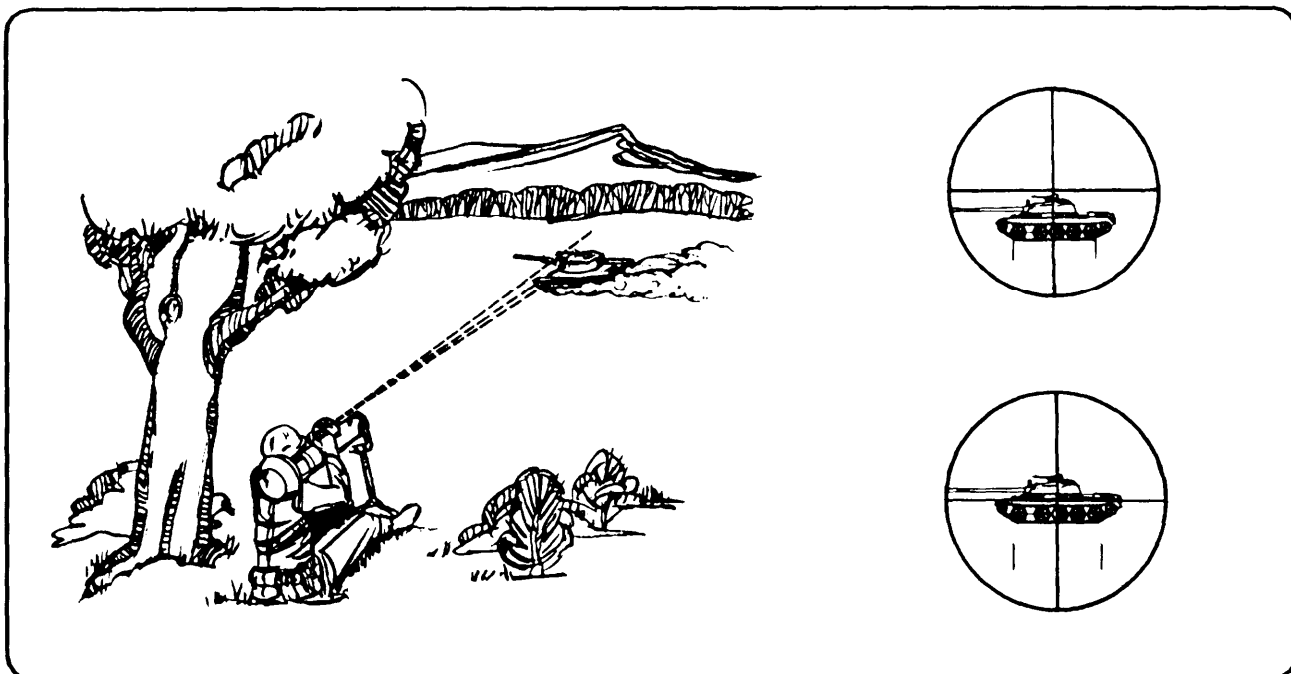

Figure 4-7. Target acquisition.

- a. Acquire and track the target IAW Chapter 3.
- b. To fire the weapon, push the safety plunger in with the thumb of the right

hand, depress and hold the trigger, and maintain the sight picture until impact (Figure 4-8). When engaging a moving target, make adjustments

by moving the upper portion of the body left or right for azimuth and up or down for elevation.

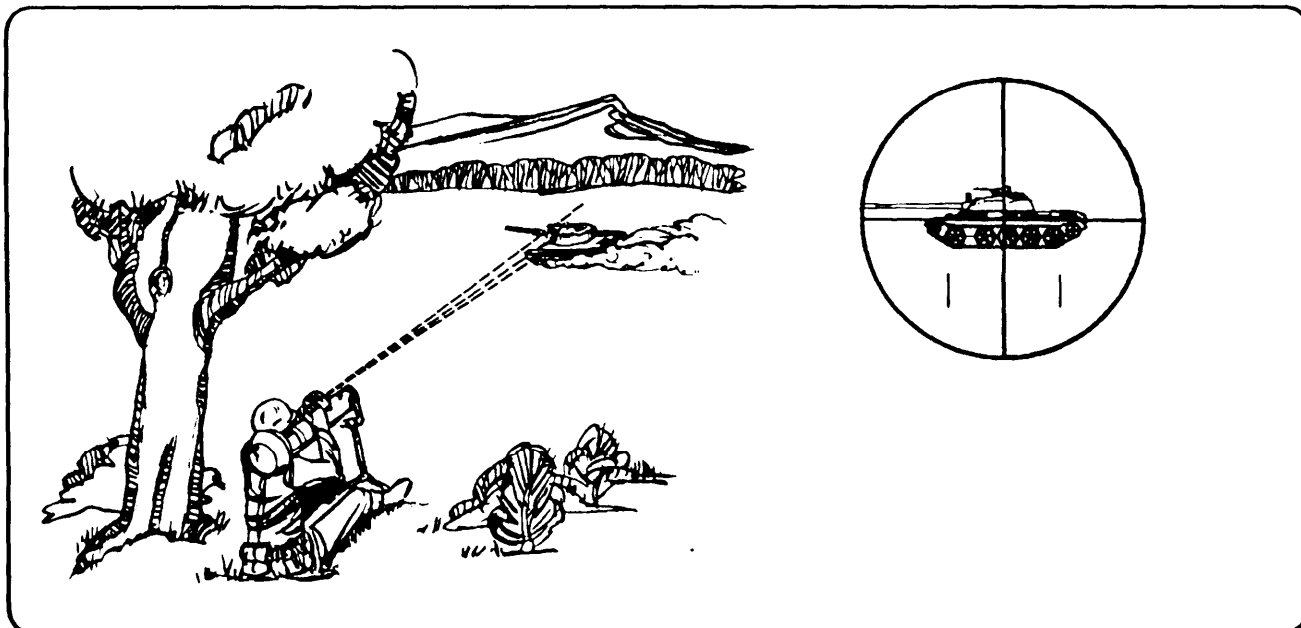

Figure 4-8. Correct sight picture maintained.

NOTE: Excessive or jerky movement of the tracker while the missile is in flight may cause you to miss the target. Track the target for about two seconds

before trigger squeeze to establish a smooth tracking rate during missile flight.

c. Ignore the missile when it appears in the sight picture. Do not try to fly

the missile. Keep the cross hairs on the target—let the tracker guide the missile.

4-6. MISSILE FLIGHT AND CONTROL

As the missile leaves the launch tube, the infrared flares begin to operate, and the command-link wire is dispensed from the missile. The missile fins fold out and lock into place. The safety and arming device sequence is completed after the missile has traveled about 65 meters (Figure 4-9).

a. The tracker electronics compares the missile position with the gunner's LOS. Then, it sends the position information to the missile electronics through the command-link wire.

b. The missile electronics generates correction commands based on missile position information received from the tracker. The missile electronics either stores the commands until the missile rolls to a proper position for rocket motor firing, or fires the rocket motors, as commanded, to correct the missile's position to the gunner's LOS.

c. Acceleration and missile position corrections are accomplished by rocket motor firings. The gunner keeps the cross hairs on the selected aiming point on the target until missile impact.

d. To fire a second round, the tracker is removed from the launcher when missile flight ends. The gunner releases the spring clip at the rear left side of the tracker support assembly and slides the tracker forward and lifts it clear of the support. The expended round will now be destroyed and discarded according to unit SOP. The gunner either prepares another round or secures the tracker and any extra rounds and prepares to displace on order.

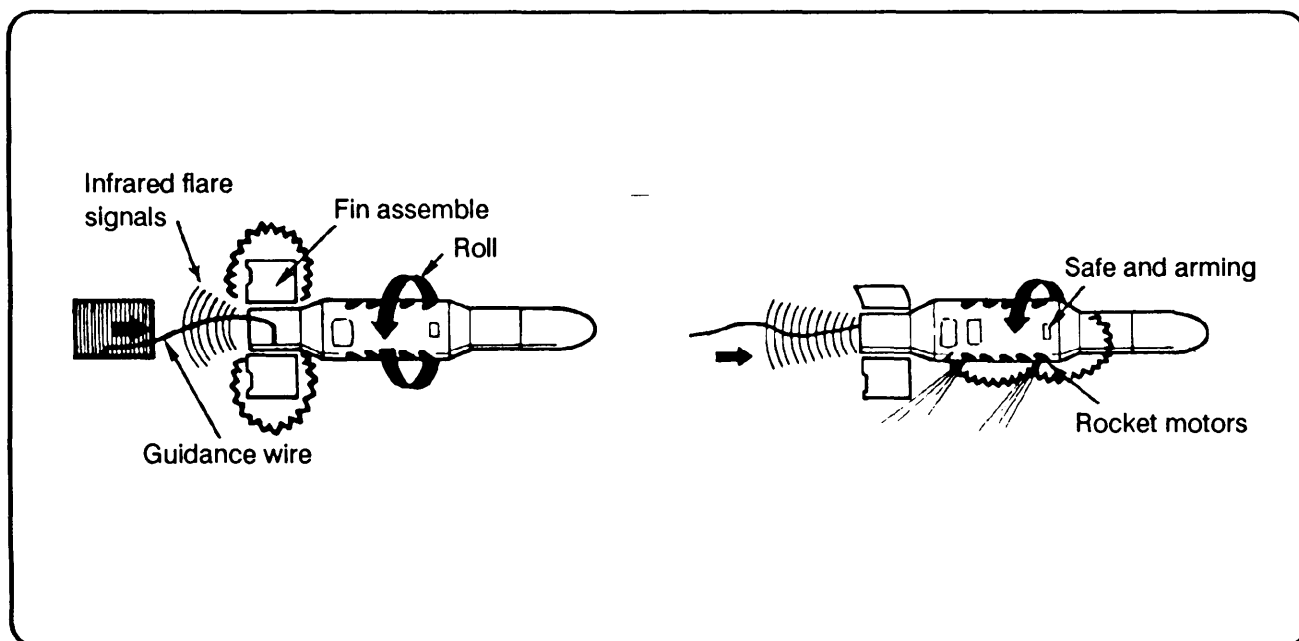

Figure 4-9. Dragon functioning concept.

4-7. FAILURE TO FIRE

A failure to fire is when the missile does not leave the launcher when the trigger lever bar is depressed. The gunner immediately resqueezes the trigger lever bar and continues to track the target for 15 seconds. If after 15 seconds the missile has not fired, the gunner announces "Misfire," releases the trigger lever bar, and carefully feels near the tracker battery. If the tracker battery is hot, the gunner performs hangfire procedures; if it is cold, the gunner performs misfire procedures.

a. Hangfire Procedures (Combat Only).

- (1) Remove the tracker from the round and place the round on the ground away from the firing site. Keep the round pointed toward the enemy advise soldiers near you of the failure to fire.
- (2) Obtain a new round and mount the tracker on the new round.
- (3) Acquire the previous target and continue with the mission.

NOTES: 1. If the Dragon is operated by a two-man team, the assistant gunner secures a new round.

2. The procedures in Note 1 detail actions that a gunner can take in an ideal situation. However, the tactical situation, which normally is a moving armored vehicle closing on your position within 1,000 meters, will probably dictate leaders to take other actions to preserve forces; for example, an emergency action SOP to cover the event.

b. Hangfire Procedures (Training Only).

WARNING: Keep the round pointed downrange.

NOTE: When firing tactical missiles on a training range, wait five minutes before performing hangfire procedures.

- (1) Notify the range officer or NCOIC that you have experienced a hangfire.
- (2) Remove the round from the shoulder and place it flat on the ground. Ensure that the biped legs are pointing to the side, with the round pointing downrange.
- (3) Move away from the position.

(4) The range officer or NCOIC clears all personnel within 50 meters of the round and notifies the EOD.

c. Misfire Procedures.

- (1) Loosen, then re-mate the tracker to the round.
- (2) Track the target and try to fire again.
- (3) If the round fails to fire again, carefully feel near the tracker battery.
- (4) If the battery is still cold, remove the tracker from the round. Place the round on the ground away from the firing site. Keep the round pointed toward the enemy; advise soldiers near you of the misfire.
- (5) Mount the tracker on another round and continue with the mission.
- (6) If the new round also fails to fire, carefully feel near the tracker battery. If the battery is cold, the tracker is probably defective.
- (7) If another tracker is available, replace the tracker and continue with the mission, using previously unfired rounds.

NOTE: See note under hangfire procedures (combat only).

4-8. DRAGON RESTORED TO CARRYING CONFIGURATION

A Dragon round that was prepared for firing but is no longer required can be moved in either one of two ways: the long-distance carry or short-distance carry. To use the long-distance carry, the gunner performs steps 1 and 2 below. To use the short-distance carry, the gunner only performs step 2 below.

STEP 1. Remove the tracker from the round.

Ž Replace the tracker lens cover.

- Next, remove the tracker from the round, and replace the connector cover on the tracker and round.

- Return the tracker to its carrying bag or rucksack.

STEP 2. Restore the round to the carrying configuration.

- Replace the connector cover.

- Replace the forward shock absorber.
 - Set the round in an upright position with the rear shock absorber resting on the ground.
 - While lightly pushing down on the biped, press the biped brace toward the round to lift it out of the locking slot.
 - Once the biped brace is unlocked, push down on the biped until the upper part of the biped that attaches to the round is parallel with the muzzle of the launcher.
 - Align the cutout portion of the forward shock absorber with the biped at the launcher muzzle.
 - Push down on the shock absorber while lowering the biped against the round.
- Ensure the upper part of the biped engages the shock absorber.
 - Retract the biped legs and secure them to the round with the retainer strap.
- Lift up on the forward shock absorber to ensure it is secure. The round is now in a safe-to-carry configuration.

4-9. ADVERSE WEATHER CONDITIONS

The Dragon can operate in all weather conditions, providing the gunner can see the target.

NOTE: The Dragon temperature is the round's temperature. For example, if it is removed from a vehicle whose inside temperature is 45 degrees, the round will be 45 degrees, even if the

outside temperature is 32 degrees.

a. **Cold Weather.** Check the optical surfaces and all mechanical devices for proper operation before deployment. Ensure no ice or snow has formed on the tracker components. Never operate the

Dragon in temperatures lower than minus 25-degrees Fahrenheit.

b. **Hot Weather.** Provide as much shade or cover as possible to avoid subjecting the round and tracker to prolonged direct sunlight. Never operate the Dragon in temperatures above plus 145-degrees Fahrenheit.

UNIT TRAINING

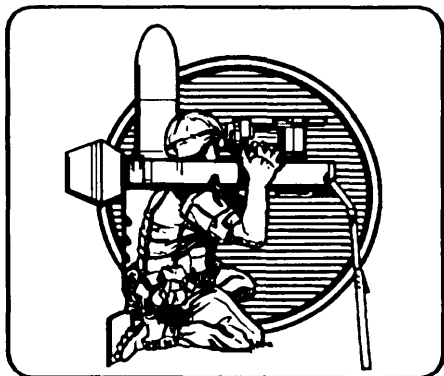

All effective unit training must meet certain requirements to obtain combat readiness. Training requirements consist of command emphasis; consolidation of planning and execution of training at battalion, brigade, or division level; close supervision of gunner and instructor selections; consolidation of training equipment and maintenance responsibility; and training to standards.

Section I. COMMANDER'S RESPONSIBILITY

The commander is responsible for planning, executing, and supervising training. He selects the instructors and gunners based on the selection criteria given in this chapter. The commander makes sure that the instructor and gunner receive training. (See Chapter 6 for instructor training and Chapter 8 for gunner training.) The commander must ensure –

• Command emphasis provides adequate time to conduct effective training.

- Training is to standard and is combined with other unit tactical training.
- The maintenance facility properly maintains all consolidated Dragon training equipment.
- Sustainment training is conducted IAW the training program discussed in Chapter 8, Section II.
- No-notice operational readiness checks of trackers, training

equipment, and gunners are made; for example –

- Day tracker, night tracker, and M175 have a DA Label 80 dated within 90 days.

- Monitoring sets are tagged to show the date last charged.

- Periodic ordnance inspections are made.
- A formal record of inspections, training results, gunner qualifications, and gunner turnover are maintained.

5-1. TRAINING GOALS AND PROGRAM

The training goals and program provide the soldier with the skills

needed to engage armored targets on the battlefield and to operate and

maintain the Dragon. Commanders must –

- | | | |
|---|--|--|
| <p>a. Train soldiers to the level needed to successfully engage armored targets.</p> | <p>c. Provide leaders clear sustainment standards and ensure they know how to meet them.</p> | <p>training to maintain their proficiency.</p> |
| <p>b. Provide training in maintenance and operations of the Dragon and on related training devices.</p> | <p>d. Ensure soldiers are trained to standard, and conduct sustainment</p> | |

5-2. INSTRUCTOR SELECTION

<p>Dragon instructors must desirably meet the same standards as gunners. They should be selected based on their desire and ability to instruct and should have a high level of</p>	<p>tactical competence at squad and platoon levels. Successful gunner experience can be an asset, but it is not an indicator of a good instructor. Once selected, the instructors must</p>	<p>know the information in Chapters 6 and 7, and must pass the performance test in Appendix B.</p>
--	--	--

5-3. GUNNER SELECTION

<p>The critical criteria of the gunner selection process are the overall evaluation of the soldier's performance and his desire to be a Dragon gunner. Personnel selected as gunners must —</p> <ul style="list-style-type: none"> • Have the desire to be a Dragon gunner. <p>Ž Be evaluated as outstanding soldiers.</p> <p>Ž Be able to flex the upper trunk, left and right. (Flexibility allows</p>	<p>the gunner to track moving targets.)</p> <p>Ž Have a strong upper body with physical stamina. (Physical stamina ensures steady-hold and the ability to carry the weapon.)</p> <p>Ž Be between 5 feet and 6 feet 2 inches in height. (The biped only adjusts for these heights.)</p> <ul style="list-style-type: none"> • Be able to hold the breath throughout the sequence of tar- 	<p>get acquisition, firing, and tracking (minimum of 13 seconds).</p> <p>Ž Have an unaided, minimum vision of 20/100, correctable to 20/20. (The focus or reticle adjustment only corrects 20/100 back to 20/20 [right eye].)</p> <p>Ž Be able to close the left eye independently (should be right-eye dominant). (The left eye must remain closed to prevent dust or debris from entering the open eye, otherwise distracting the gunner.)</p>
---	---	--

Section II. DRAGON TRAINING OVERVIEW

<p>Successfully applying the tactics and techniques for employing the</p>	<p>Dragon in battle depends on the effectiveness of each unit's Dragon</p>	<p>training program within the unit's overall training program.</p>
---	--	---

5-4. DEVELOPMENT OF A UNIT TRAINING PROGRAM

It is unlikely that a mandatory training program would fit each unit's circumstances and needs. Only the commander is in a position to develop his unit's training program.

a. To develop a unit training program, the commander uses the following nine steps:

STEP 1. Identify all of the unit's tactical and administrative missions.

STEP 2. Analyze the unit's missions to determine the individual and unit

tasks required to accomplish each mission. (See Table 5-1 for minimum requirements.)

STEP 3. Establish individual and unit training objectives to accomplish the unit's tasks.

STEP 4. Determine the level of individual and unit proficiency of those tasks.

STEP 5. Determine individual and unit training needed to attain the training objectives established in STEP 3.

STEP 6. Identify available training resources.

STEP 7. Program and schedule training based on the training resources available and individual and unit training needs.

STEP 8. Conduct training.

STEP 9. Monitor and evaluate training, and revise the training program, as required.

INDIVIDUAL TASKS AND TRAINING OBJECTIVES		S L	TYPE UNIT		
			NONMECH	MECH	CS
071-052-0001	MAINTAIN AN M47 MEDIUM ANTITANK WEAPON				
TO 1	Perform PMCS on the M47 Dragon Weapon System	1	X	X	X
TO 2	Perform PMCS on the M47 Support Equipment	1		X	
071-317-3302	PREPARE AN M47 MEDIUM ANTITANK WEAPON FOR FIRING				
TO 1	Select a Carrying Position	1	X	X	X
TO 2	Prepare the Round for Firing	1	X	X	X
TO 3	Prepare the M175 Mount on an M113 for Firing	1		X	
TO 4	Mount the M175 Mount on a Machine Gun Tripod (M3/M122)	1		X	
TO 5	Load an M222 Round in an M175 Mount	1		X	

Table 5-1. Individual and unit tasks and training objectives.

INDIVIDUAL TASKS AND TRAINING OBJECTIVES		S L	TYPE UNIT		
			NONMECH	MECH	CS
071-052-0006	ENGAGE TARGETS WITH AN M47 MEDIUM ANTITANK WEAPON				
TO 1	Demonstrate Correct Firing Positions	1	X	X	X
TO 2	Determine if a Target is Engageable	1	X	X	X
TO 3	Qualify with Launch Effects Trainer	1	X	X	X
TO 4	Demonstrate Correct Firing Positions for Machine Gun Tripods	1		X	
TO 5	Fire the Launch Effects Trainer Mounted on an M113 with the M175 Mount	1		X	
071-317-3306	PERFORM MISFIRE PROCEDURES ON AN M47 MEDIUM ANTITANK WEAPON				
TO	Perform Immediate-action Procedures for a Dragon Hangfire/Misfire	1	X	X	X
071-052-0004	RESTORE AN M47 MEDIUM ANTITANK WEAPON TO CARRYING CONFIGURATION				
TO 1	Restore the FHT to a Carrying Configuration	1	X	X	X
TO 2	Prepare the M175 Mount for Travel on an M113	1		X	
TO 3	Dismount the M175 Mount from a Machine Gun Tripod (M3/M122)	1		X	
TO 4	Stow the M175 Mount for Travel	1		X	
071-317-0000	PREPARE AN ANTIARMOR RANGE CARD				
TO	Same as Task	1	X	X	X

Table 5-1. Individual and unit tasks and training objectives (continued).

INDIVIDUAL TASKS AND TRAINING OBJECTIVES	S L	TYPE UNIT					
		NONMECH	MECH	CS			
878-920-1002							
TO 1							
TO 2							
071-052-0003							
TO 1							
TO 2							
PERFORM EMERGENCY DECONTAMINATION PROCEDURES FOR AN M47 MEDIUM ANTITANK WEAPON							
TO							
PERFORM EMERGENCY DESTRUCTION OF AN M47 MEDIUM ANTITANK WEAPON							
TO							
LEADER TASKS AND TRAINING OBJECTIVES							
071-317-3324							
TO 1							
TO 2							
TO 3							

Table 5-1. Individual and unit tasks and training objectives continued.

LEADER TASKS AND TRAINING OBJECTIVES		S L	TYPE UNIT		
			NONMECH	MECH	CS
TO 4	Identify Target Reference Points (TRP)	2/3	X	X	X
TO 5	Identify Dragon Firing Limitations	2/3	X	X	X
TO 6	Supervise Preparation of the Range Card	2/3	X	X	X
TO 7	Supervise Construction of Fighting Position	2/3	X	X	X
CONTROL ANTIARMOR FIRES					
TO 1	Issue a Fire Command	2/3	X	X	X
TO 2	Assign Sectors of Fire	2/3	X	X	X
TO 3	Prepare a Sector Sketch (Squad/Team)	2/3	X	X	
ANTIARMOR SECTION ONLY					
	PREPARE A DRAGON FIRE SUPPORT PLAN	2/3	X		
	PLAN FOR RECONNAISSANCE, SECURITY, AND COMBAT PATROLS	2/3	X		
	LEAD COMMAND POST SECURITY ELEMENT	2/3	X		
	PLAN FOR AMMUNITION RESUPPLY	2/3	X		
	ORGANIZE ARMOR-KILLER TEAM	2/3	X		
	PLAN THE EMPLOYMENT OF THE DRAGON IN THE OFFENSE, DEFENSE, AND RETROGRADE	2/3	X		

Table 5-1. Individual and unit tasks and training objectives (continued).

b. The key step in developing a training program is to consolidate training at brigade level. For consolidation to be successful, a unit must –

- (1) Assign a qualified NCO full time as the principal instructor,
- (2) Make Dragon training an item of command interest.

(3) Designate the S3 as the officer responsible for ensuring that Dragon training is performed and coordinated with other unit training.

c. The training programs in this manual are to be used as the basic documents for conducting Dragon training. They list all of the tasks and training objectives needed for initial and sustainment training (Chapters 6 and 8).

(1) Certify each Dragon instructor by using the program in Chapter 6.

(2) After instructors are certified, use the training program in Chapter 8, Section I, to train each gunner.

(3) Use the training program in Chapter 8, Section II, to sustain gunners.

5-5. TRAINING FOR SPECIFIC NEEDS

Concentration on the specific training needs of individuals and units provides a commander two important advantages as he plans and conducts Dragon training; he can allocate his training resources more effectively and his soldiers can learn easier and faster.

a. Because of limited training resources, such as lack of time, instructors, and ranges, or it becomes critical to identify the

specific training needs of individuals, teams or crews, and units (squads and platoons). Soldiers can learn easier and faster if their essential training needs for duty performance are recognized. During training, a soldier is required to learn new information, acquire new skills, and practice these skills to attain or exceed established levels of proficiency.

b. Therefore, those who plan and conduct training should ensure that they do not include useless information in a class or require a soldier to practice an unnecessary skill. To do so can only reduce the soldier's learning by forcing him to separate the "essential" from the "nice to know" information, or to force him to practice a skill he can already perform or does not need to perform to complete a given training objective.

5-6. MULTILEVEL TRAINING

Various duty positions in a unit require different skills, which require different training. Recognition of this fact suggests the use of a multilevel training approach. This approach is designed to train different elements at the same time (leaders, squad, Dragon gunners, assistant gunners) of the unit; for example, the unit before training in a platoon or company FTX.

a. Applying the logic of the multilevel training approach to Dragon training a training program can be developed for each of the following categories:

(1) *Team and unit performance.* Because team and unit performances are greatly affected by the decisions and actions of its leaders, leaders should be trained to make critical (tactical) decisions before they train with their team or unit. Such leader training reduces the chance that the soldiers will be used as "training aids" for the leaders. Squad and platoon leaders

can begin to train in tactical operations that require the employment of the Dragon by using one or more tactical exercises; for example, CPX, terrain exercises, or terrain model exercises. Therefore, leaders can learn and practice their tactical skills without wasting their soldiers' time. The soldiers can learn how to perform their jobs under the direction of qualified officers and NCO instructors.

(2) *Training of critical tasks performed by team and unit members.* The critical member of the team or unit is the Dragon gunner. Although every man in the unit could be trained to prepare the weapon for firing, to launch the missile, and to track a target, only the gunner is trained to be proficient in all of these skills. The Dragon is a simple weapon to operate, but skill in tracking a target requires repetitive practice with the LET (includes monitoring set and target board) to acquire proficiency and reliability as a gunner. See the following list for

the critical tasks of each team member.

(a) Platoon leader:

- Identifies enemy avenues of approach.
- Assigns squad defensive sectors.
- Selects firing positions for the platoon's Dragons.
- Assigns Dragon sectors of fire.

NOTE: The knowledge and skills required to perform any of these tasks are considerable; for example, map reading, map and terrain analysis, knowledge of enemy armor capabilities in determining armor approaches, and knowledge of the Dragon's range, and backblast effects.

(b) Squad leader:

- Posts local security, and the soldiers and weapons to the positions selected by the platoon leader.

- Directs that fields of fire are cleared and improved.
- Ž Directs that positions are prepared; orients on assigned sectors of fire; uses natural cover and concealment to advantage and improves it.
- Ž Directs that range cards are prepared.
- Coordinates with adjacent units to ensure mutual support.

NOTE: Like the platoon leader, the squad leader has specific tasks and must have the knowledge associated with each skill needed to perform his job. Although some of the tasks are similar to the platoon leaders, they differ in scope and degree of proficiency.

(c) Dragon gunner/assistant gunner:

- Ž Identifies and verifies his position and sector of fire.

Ž Prepares his position (entrenches, camouflages, and conceals).

- Locates various points (terrain features) in the sector of fire that serve as reference points during target engagement; for example, maximum and minimum ranges.

- Prepares range cards.

Ž Improves positions and prestocks Dragon rounds.

b. In a unit with a high-priority antiarmor mission, the commander may decide that every man in the unit should be trained in the use of the Dragon; for example, prepare the round for firing, acquire a target, launch the missile, keep the cross hairs on the target until missile impact. Because this type of familiarization training represents an investment of training resources, the commander should know the

degree of proficiency that will result from his training time. Commanders must realize that training men to fire the weapon does not constitute gunner qualification or proficiency.

c. Gunner qualification is based mainly on proficiency—the ability of the gunner to successfully and consistently track and hit targets. To gain this skill requires a great amount of time (a critical resource) practicing on the LET. A LET is a training device (also a resource) of limited availability (three LETs for each battalion). Commanders must determine who will be the unit’s qualified gunners and what training resources can be allotted to their training. With this determination, he can then select training resources for familiarization training for other unit members.

5-7. LEADER TRAINING

Dragon training for leaders and commanders begins by determining the specific Dragon-related tasks that each leader or commander must perform. Once these tasks are developed into training objectives, the instructors can select the proper training methods for the available resources and other training

requirements. If commanders assume that the leaders and commander initially know little about how to employ the Dragon, training should progress from the basic to the more difficult part of Dragon employment. The starting point can be presenting information in the classroom. Initial Dragon

instruction can be conducted in a classroom without wasting training resources (ranges, transportation, and so forth). Lectures, seminars, small discussion groups, and briefings lend themselves to the classroom.

5-8. GUNNER TRAINING

There is a difference between the tactical employment of Dragon and the technical aspects of its operation,

maintenance, and firing. Dragon employment during tactical operations is mostly a conceptual

process for platoon leaders and company commanders; execution of

these concepts is a mechanical process for Dragon gunners.

a. **Gunnery.** Gunnery includes the ability to fire the weapon (day and night) and track the target until missile impact. Gunners must —

- (1) Detect vehicles at ranges out to 1,500 meters, under varying field conditions (rolling hills, vegetation, and so forth), moving and stationary.
- (2) Determine if a moving target, if engaged, will reach cover before impact.
- (3) Prepare a firing position, to include range card preparation.
- (4) Know how to lessen the signature of the backblast.
- (5) Know the ability of the enemy to place suppressive fires on his firing position, thus requiring the gunner to use cover and concealment, deception, surprise, movement, and so forth.
- (6) Know unit SOPs covering rules of engagement to include signals to lift or shift fires, priority of targets, when to engage targets, and so forth.
- (7) Know where to obtain resupply of missiles.
- (8) Know how to inspect the round before firing.

b. **Centralized Versus Decentralized Gunner Training.** The decision to use centralized or decentralized gunner training depends on the available training resources (for example, equipment and facilities, personnel, time) and the type of tasks to be taught.

(1) Limited training resources may dictate a centralized approach.

(a) Equipment and facilities. The need for centralized training can be made based on the training equipment. Limited distribution of the training equipment suggests centralized control of training at the battalion (or brigade) level. Also, the number of firing ranges suitable for the Dragon may dictate centralized control over these facilities.

(b) Personnel. The lack of qualified Dragon instructors can hamper gunner training.

(c) Time. A unit can save training time by centralizing the conduct of Dragon training since centralized training requires fewer instructors and classes. If the training is centralized at brigade level or higher, battalion and company level instructors can devote their time to other training requirements. Centralized training permits the use of qualified Dragon instructors to prepare and conduct training. These men will need less time to prepare Dragon instruction than unqualified Dragon instructors.

(2) The commander also considers the types of tasks to be taught as he decides between a centralized or a decentralized approach. If the task is related to gunnery training or qualification, the commander may be forced to use a centralized approach because of the limited number of training sets and ammunition. But if the task is for example, to prepare range cards, a decentralized approach may be better. Once the Dragon gunners learn the basic elements for

preparing range cards, the training task becomes one of practicing the application of these elements to different pieces of terrain or terrain substitution; for example, maps, sand tables, 35-mm slides of terrain. Such practices can be enhanced by working in small groups where soldiers have the opportunity to ask questions, discuss answers, and debate the advantages and disadvantages of the range cards.

c. **Training Techniques.** Several types of gunner training techniques are discussed herein.

(1) *Round-robin.* Because of the limited number of training sets in the battalion, all gunners cannot practice at the same time. Rather than have a few gunners practice on the training equipment while other soldiers watch, a round-robin setup could be used to keep all the soldiers engaged in productive, active training. The round-robin setup is a series of concurrent training stations through which each platoon member rotates. For example, Station Number 1 may be for the training equipment, Station Number 2 may require preparation of range cards, Station Number 3 may require identification of enemy tanks through the use of flip charts (Figure 5-1).

(2) *Night training.* Since Threat doctrine stresses night operations, gunners should practice their skills at night. This can be done during FTXs using the FHT with the night tracker or on a range (under controlled conditions), and using artificial illumination to illuminate targets.

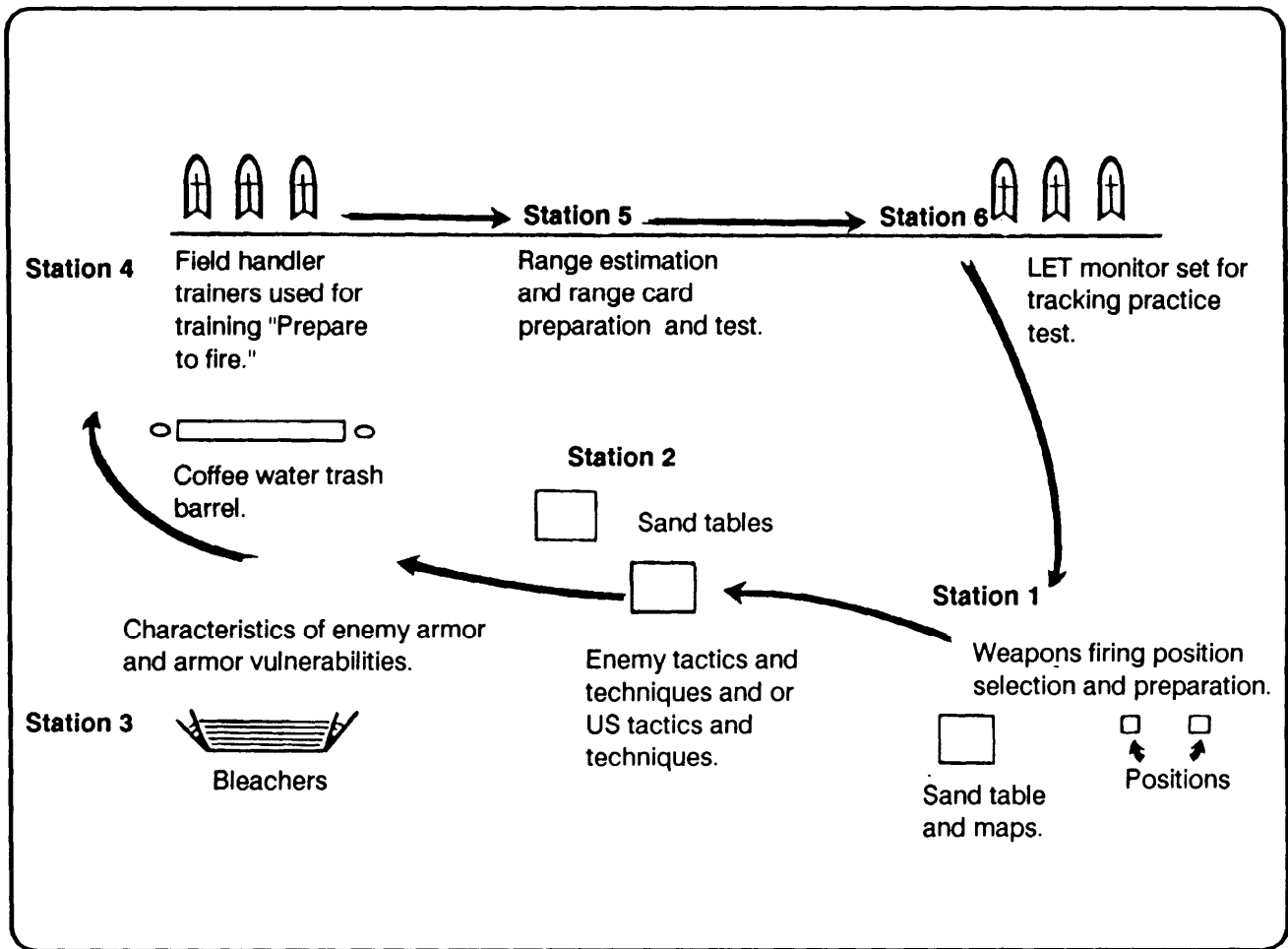

Figure 5-1. Example of round-robin.

5-9. TEAM TRAINING

Because of the frequent need for squad leaders to employ Dragon as part of a team, team training must become an integral part of Dragon training in the field. As a rule, when Dragon gunners are employed apart from their squad positions, they have at least one assistant gunner and ammunition bearer with them, or may be employed in an antiarmor fire team. The other members of the team must work with the gunner as a coordinated element whose duties include providing security for the

gunner, assisting the gunner in preparing his firing position, carrying ammunition (missiles), and locating targets. To simplify training, members of the gunner's own fire team within the squad should be used to form the team.

a. Once gunners are trained and qualified with the weapon and leaders are trained in the tactical employment concepts of the Dragon, leaders and gunners can train together profitably during field exercises. During the conduct of

such training, leaders must be forced to make decisions about the employment of the weapon, which can be done through the use of scenarios, simulated threat conditions, OPFOR, and so forth. Based on these simulated conditions, platoon leaders practice choosing armor avenues of approach, selecting Dragon firing positions, and all the other elements of employing the weapon. Platoon and squad leaders, in turn, should require their gunners to prepare

firing positions, to prepare range cards, and to simulate target engagement. Employing gunners with their squads provides training for other squad or fire team members' duties (providing security, locating targets, and so forth). The training exercises should be critiqued and discussed to determine if the techniques and tactics were the best possible for the situation.

b. When qualifying on the range, Dragon gunners normally learn under almost ideal conditions. The gunners have excellent fields of fire, the target (infrared source) moves back and forth in front of them on level ground, and there are no distractions other than fellow gunners firing their weapons. Once the Dragon gunner has qualified on

the range, he is ready for more advanced training. This advanced training consists of requiring the gunner to use the Dragon under increasingly harder, yet realistic, conditions. Such conditions must be created during training by the commander. A few examples of how to add realism to Dragon training are discussed in the following paragraphs:

(1) During both FTXs and practice firing exercises on the range, gunners should be exposed to distracters. These include the detonation of explosives to simulate enemy artillery and tank fires near his position. The use of smoke, both on or near the gunner's position or target, also add realism. (A good technique to simulate close explosions is to use explosives under

a bag of flour.) Such items tend to distract the gunner, and resemble the type of interference to be faced on the battlefield. Smoke obscures the target, making tracking more difficult. Gunners must concentrate on tracking their targets under varying degrees of smoke, haze, and harassing fires.

(2) During tracking exercises using the MILES Dragon, the target vehicle mounted with the MILES receivers must be used over representative terrain--thus, the target would move toward the gunner's position over rolling, wooded terrain, curving roads, and so forth. Simply driving the target vehicle back and forth across a flat field in front of the gunner marginally provides effective training.

5-10. COLLECTIVE TRAINING

In addition to monthly/quarterly training and qualification, Dragon gunners must demonstrate their proficiency during squad and platoon exercises. Each Dragon gunner, as part of a squad or larger

unit, must participate in a live-fire exercise and a platoon external evaluation to ARTEP 7-8-MTP standards semiannually. Live-fire exercises should use actual Dragons or LTIDs in connection with other

small-arms targets. Platoon external evaluations should include medium antiarmor weapons tasks and be conducted as part of a company FTX/STX

5-11. EVALUATION

One of an instructor's major responsibilities is to evaluate training. The training to be evaluated may be that which he conducted himself, conducted by his assistant instructor(s), or conducted by

another instructor. The evaluation is concerned with two aspects: the effectiveness and efficiency of training. The effectiveness of training is determined by whether the soldiers, teams, or units meet the

standards established in the commander's training objective(s). The efficiency of training is concerned with how the instructors used the available training resources.

TRAINING EQUIPMENT AND INSTRUCTOR TRAINING

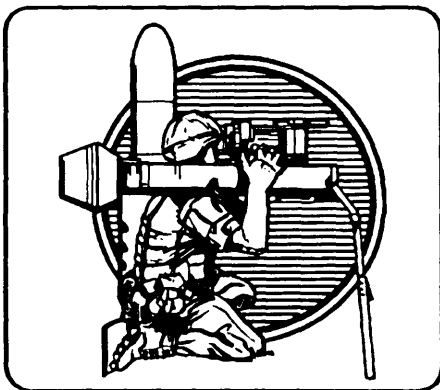

Training equipment provides units with a low-cost means to develop and maintain gunner skills. Instructors must know the Dragon and training equipment to train gunners. This chapter describes the training equipment for the Dragon and provides a program to train instructors on training equipment use.

Section I. GUNNERY TRAINING EQUIPMENT

The training equipment is used with the tactical tracker and other tactical hardware for realism. Gunnery

training equipment is issued to units equipped with authorized tactical trackers. Units are responsible for

proper maintenance of assigned training equipment. (See Figure 6-1.)

6-1. LAUNCH EFFECTS TRAINER

The LET simulates the tactical round in appearance, weight, center of gravity, and some launch transient characteristics (Figure 6-2). The LET uses the M64 blank rifle grenade cartridge to simulate the noise, recoil, and weight shift from the gunner's shoulder and the time

delay between trigger squeeze and launch.

NOTE: The weight shift of the Dragon round is more than the LET. If the gunner has adopted the correct holding technique, the weight shift will not be noticed.

a. The LET does not simulate Dragon launch. During the launch, there is a temporary obscuration of the gunner's view. The Dragon LET does not simulate the heat, flame, and dust of the launch or the appearance of the missile to block the gunner's view.

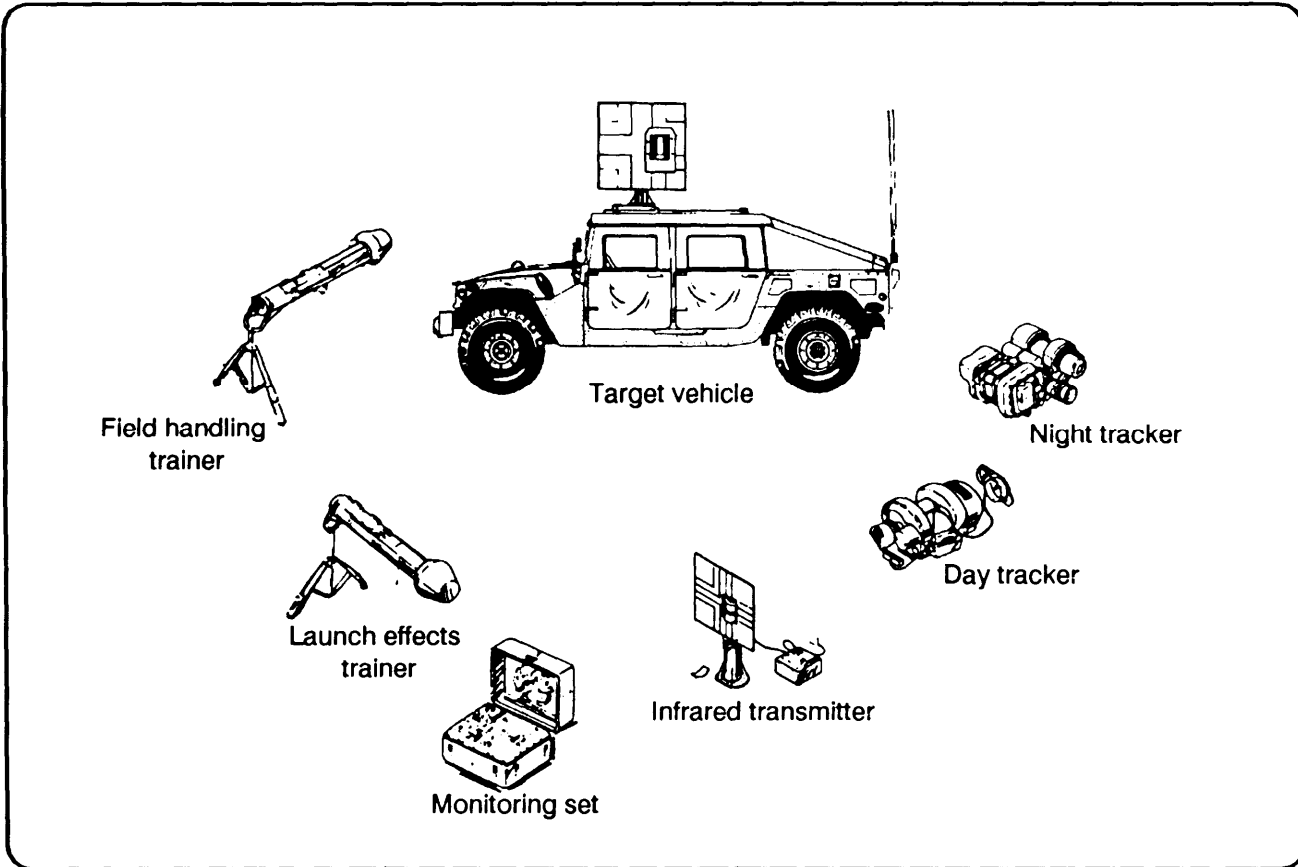

Figure 6-1. Gunnery training equipment.

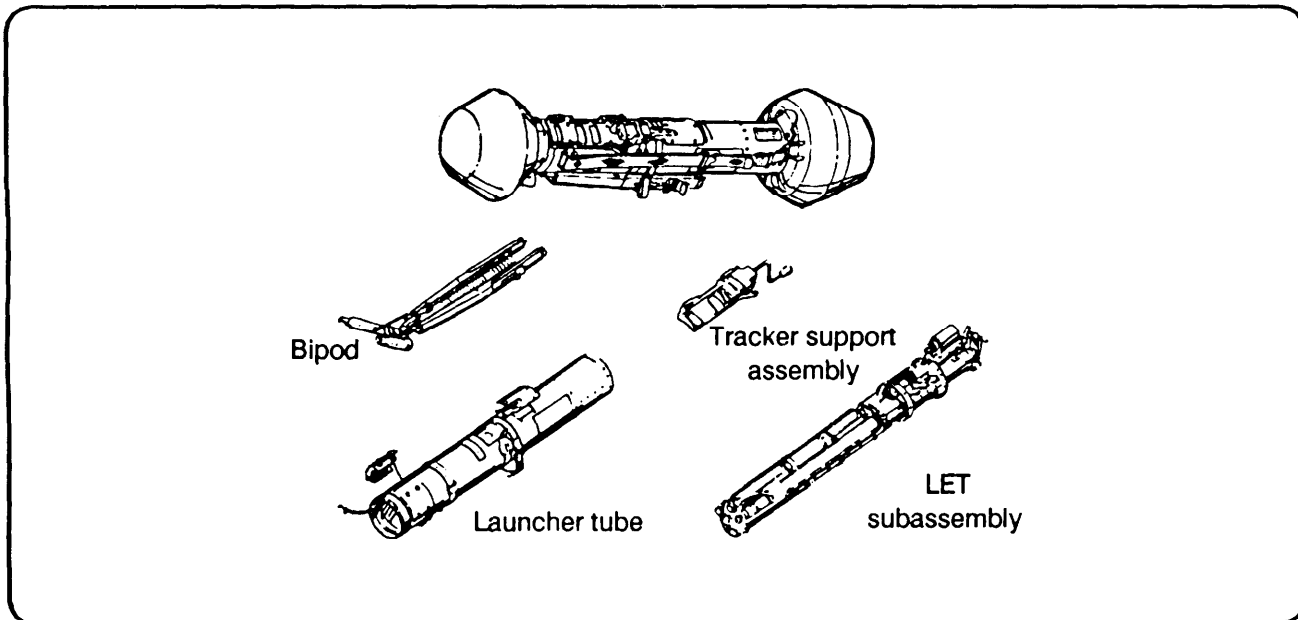

Figure 6-2. LET components.

b. The LET consists of a biped, launcher, tracker support assembly, and LET subassembly. Attached to the launcher are the forward and rear shock absorbers and the sling. The biped assembly includes a tube and yoke assembly with a brace latch. A modified tactical version of

the tracker support assembly is employed for multiple use, which supports and secures the tactical tracker in place. It also provides the electrical interface between the tracker and LET (Figure 6-2).

c. The LET allows a gunner to use any firing position shown in Figure

6-3. One set of training equipment ideally should not be closer than 6 meters to another set. The LET can be fired by itself or with the monitoring set, which evaluates gunner performance data and displays the results.

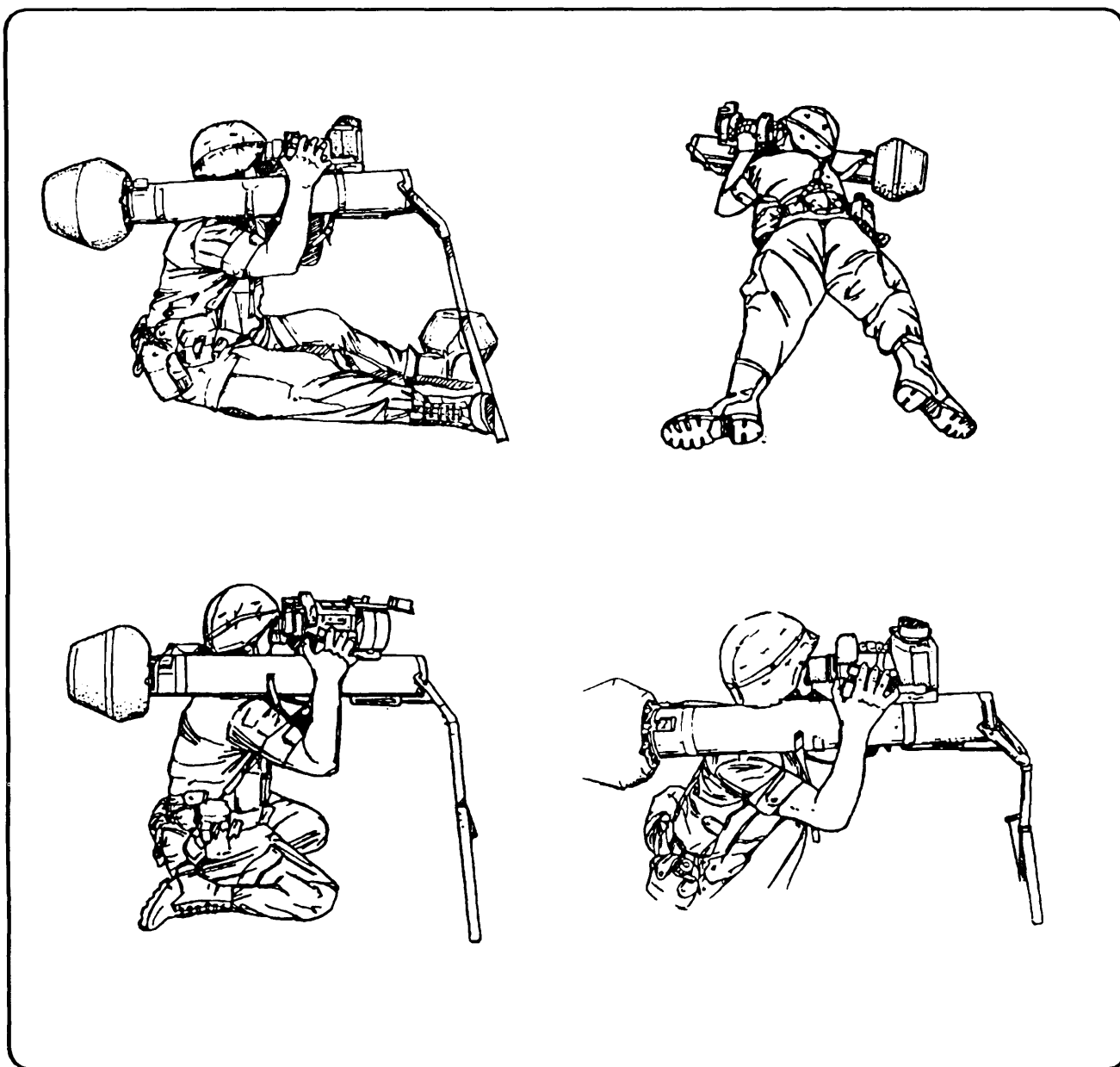

Figure 6-3. Firing positions.

d. The LET shipping and storage container (Figure 6-4) is used when the LET is transported or stored. The cleaning brush is used to clean the LET and has a pushrod for resetting the weight.

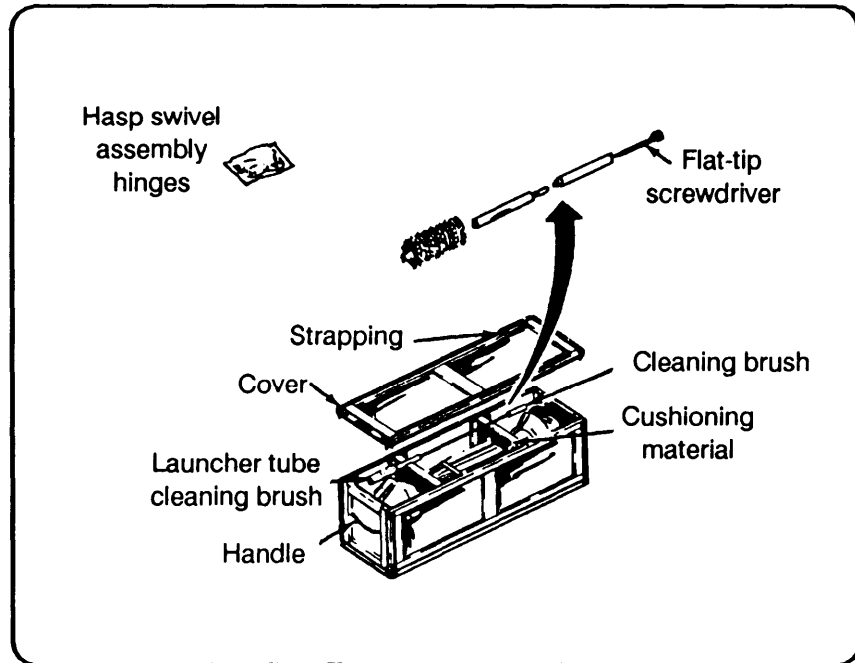

Figure 6-4. LET shipping and storage container.

6-2. AN/TSQ-1 MONITORING SET

The monitoring set monitors and evaluates the gunner's tracking performance (Figure 6-5). The set is powered by self-contained, rechargeable batteries.

a. The monitoring set case assembly consists of two sections. The *top section* of the monitoring set provides storage for the five electrical cables and operator's manual. The *bottom section* (base) contains the monitor control and display panel, electronic assemblies, humidity indicator, battery packs, and battery charger.

(1) The monitoring set battery packs consist of four 10-VDC batteries, which provide power for the

regulated plus or minus 13-VDC needed to operate the monitor and tracker. The battery packs are rechargeable by using any of the following power sources: 18-VDC to 30-VDC, 190-VAC to 230-VAC (50 to 100 Hz), and 105-VAC to 130-VAC (50 to 400 Hz).

(2) The control panel has a mounting for the monitoring set controls, indicators, lights, and connectors. (See Figure 6-6.) The J connectors are on the control panel to provide connection points.

(a) The J1 LET connector, used with the trainer, provides for input stimuli to the monitoring set circuits.

(b) The J2 recorder connector is used to supply input signals to a chart recorder.

(c) The J3 MON TEST SET connector provides test points for use during maintenance and calibration of the monitoring set.

(d) POWER INPUT connector is used during battery charging.

b. The monitoring set provides two scoring functions. One function indicates the probability of the missile hitting or missing the target, and the direction and range at which the maximum aiming deviation was exceeded, resulting in the monitoring set registering a MISS. The other function indicates numerically the gunner's ability to maintain a steady aim point.

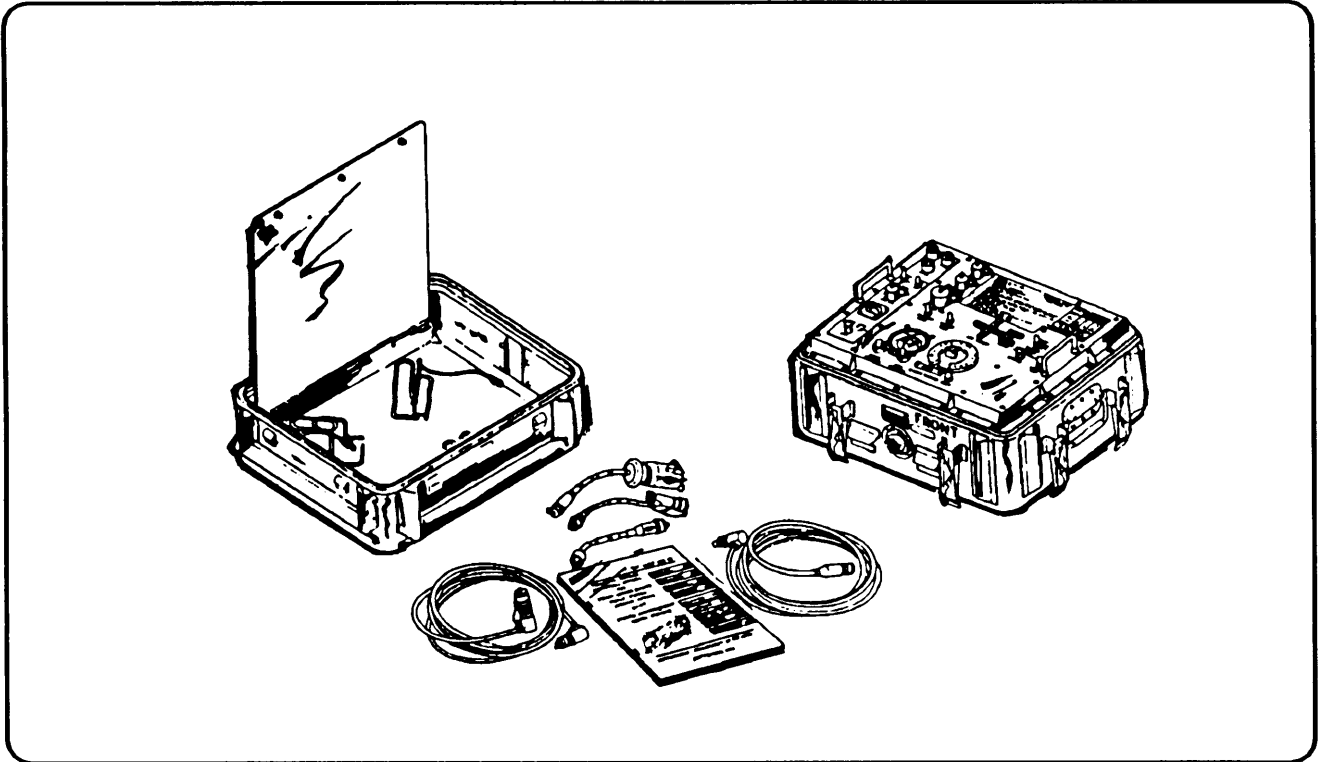

Figure 6-5. Monitoring set with components and cables.

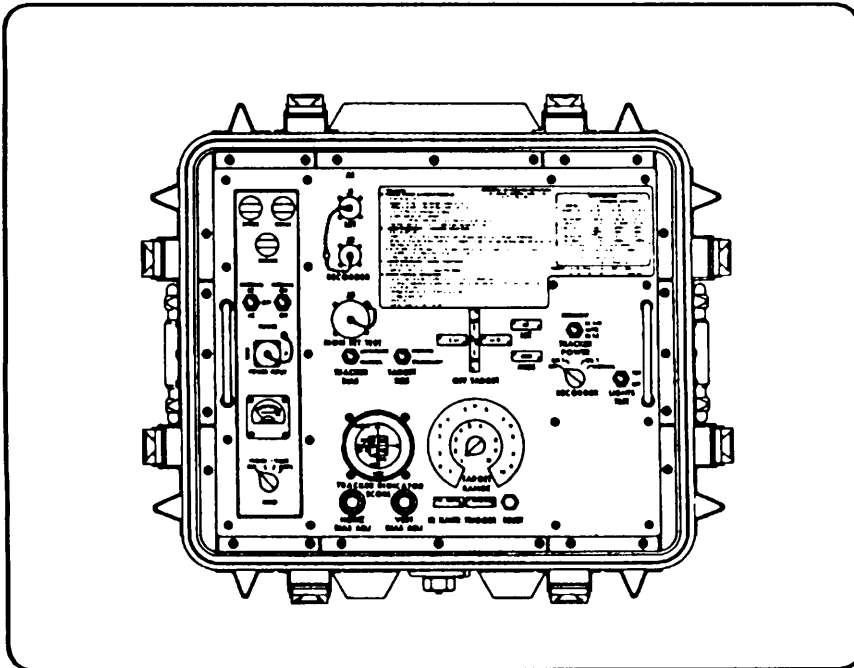

Figure 6-6. Monitoring set control panel.

(1) HIT or MISS indications are not directly related to numerical scores. The monitoring set can register a high score with a MISS indication, or a low score with a HIT indication. This depends on whether the gunner's aiming deviations exceeded the maximum aiming deviation limits.

(2) The gunner's aiming deviation shows his aim point with respect to the desired target aim point (Figure 6-7).

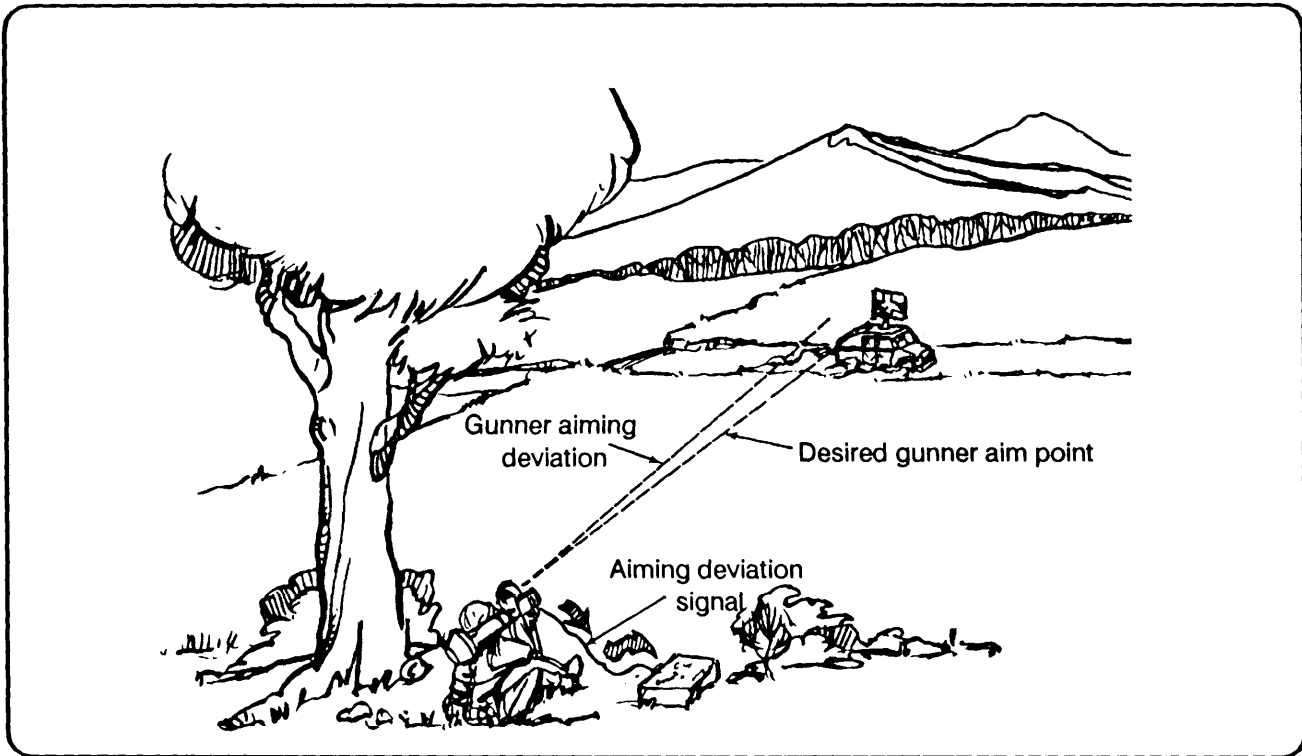

Figure 6-7. Gunner aiming deviation.

6-3. M89 INFRARED TRANSMITTING SET

The infrared transmitting set is vehicle-mounted and is used with the LET or LES and monitoring set (Figure 6-8).

a. The target set can be used in any simulated tactical operation. It operates in all weather conditions in which the gunner can track the target. The target set is used for gunner indoctrination, tracking instruction, practice, and qualification.

b. The infrared transmitter operates with any 24-VDC 40-amp system. It can be mounted on the M113 APC,

M151 1/4-ton truck, HMMWV 1 1/4-ton truck, M60A1 tank, or M561 Gamma Goat. The target source generates an infrared beam that simulates an in-flight missile. As the gunner tracks the target board, the infrared receiver in the tracker picks up the beam. This information is processed by the monitoring set to score the gunner. The components of the infrared transmitting set areas follows:

WARNING: During operation, do not look into the target source lamp when in the danger zone. (See Figure 6-9.) Do not look at the target source through vehicle mirrors or any other reflective surface. Serious eye damage could result, requiring immediate medical attention. Also, do not look into the infrared lamp (target source) when within 3 meters of the target source.

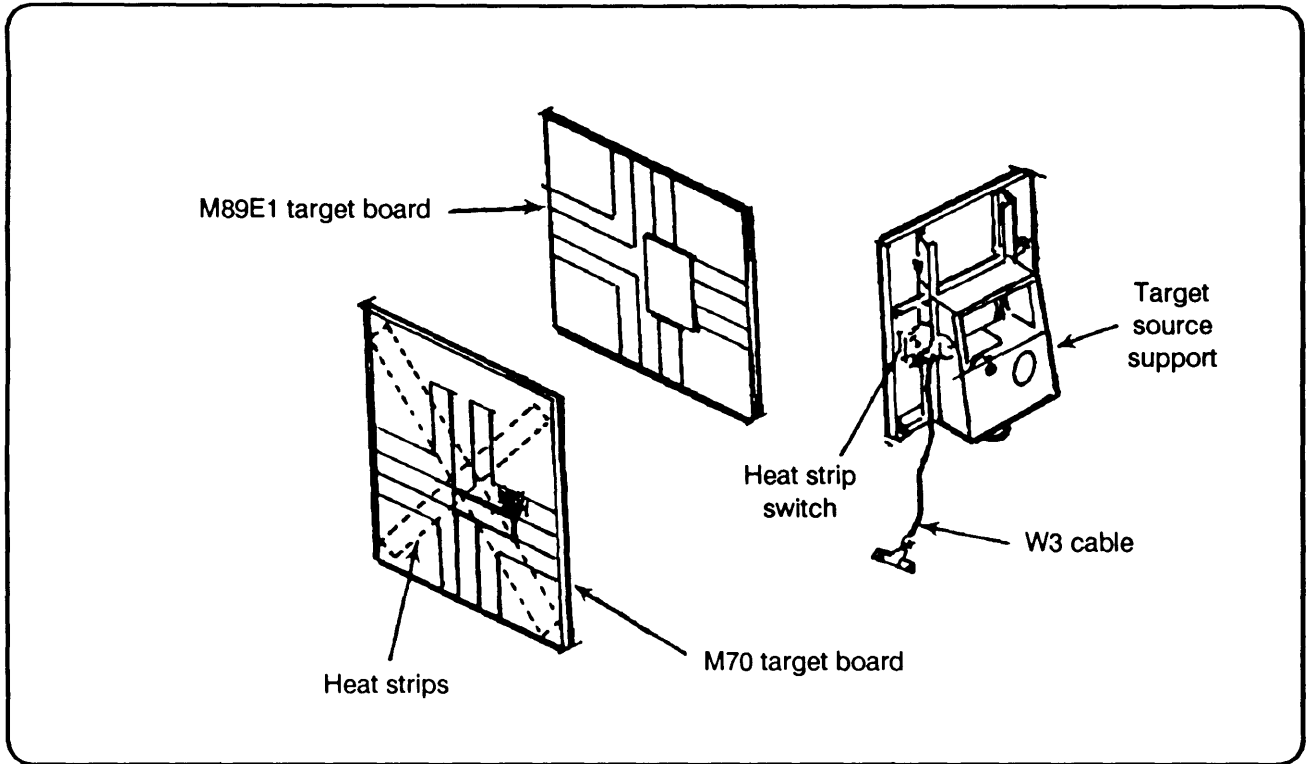

Figure 6-8. Infrared transmitting set.

(1) *Target source.* The target source operates at training frequency (5 KHz) and simulates the missile flare. Personnel must not enter the danger zone while the target source is operating (Figure 6-9).

(2) *Target source support.* The target source support is an aluminum, rectangular box that houses the target source, provides a mounting surface for the target board, provides cable storage, and mounts to the pedestal.

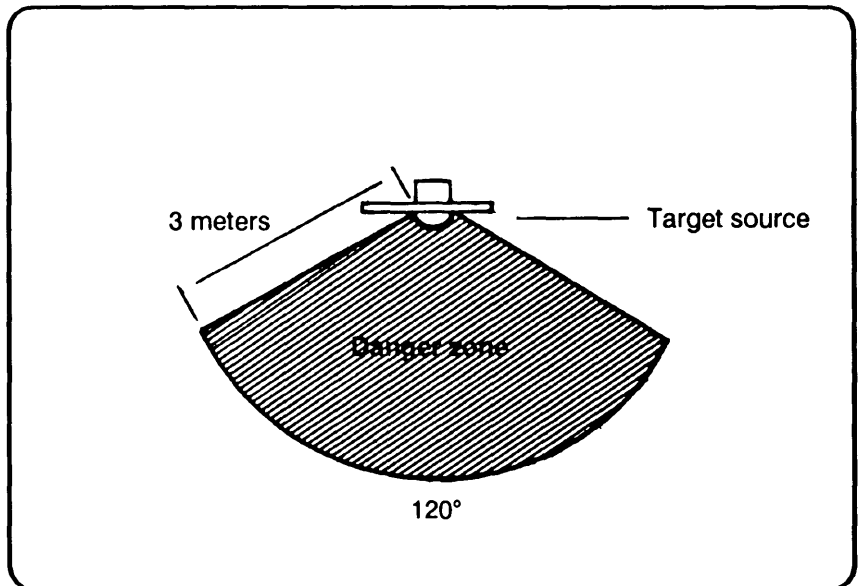

Figure 6-9. Target source danger zone.

(3) *Target board assemble.* The target board assembly is an aluminum alloy board with a red cross painted on a white background. It is used as the aiming point for the gunner.

(4) *Power supply modulator.* power supply modulator provides

power to and controls the operation of the target source.

(5) *Connecting cables.* The target source cable carries starting and drive currents from the PSM to the target source. The power supply/modulator battery cable

connects the PSM with the vehicle electrical system.

(6) *Target mounting kit.* The target mounting kit consists of a pedestal, universal adapter plate, four cargo slings, and related hardware. It serves as a base for the infrared transmitter.

6-4. FIELD HANDLING TRAINER

The FHT is a spent tactical round refurbished to simulate the tactical round in weight and shape. It provides a gunner with practical experience in tactical deployment, handling, aiming, and tracking. An FHT consists of the following modifications:

a. The remains of the rear shock absorber are removed from the spent round, and a new rear shock absorber is bonded in place. The tracker electrical connector is removed. A weight simulator, M8E2, is secured in the spent round with three screws, and a forward shock absorber is installed on the round.

b. The launcher color band and warhead color band are painted over. The propulsion color band is changed to a 1-inch (2.54 centimeters) bronze band. The word EMPTY is painted in 1-inch (2.54 centimeters) white letters on the side of the launcher.

6-5. LAUNCH ENVIRONMENT SIMULATOR

The LES is about the same size, shape, and weight as the tactical round and simulates its launch environment. (See Figure 6-10.) The LES uses a combination of MAPP gas, oxygen, and biodegradable end caps to produce a realistic simulation of the Dragon launch. The LES launcher is shipped with a blast deflector, which should be installed on the rear of the launcher. The blast deflector causes the rear of the launcher to rise during the firing sequence. This simulates the

shoulder weight loss experienced when launching a missile.

a. The LES is used with the Dragon trackers, monitoring set, and infrared transmitting set. This gives an accurate evaluation of gunner performance during training exercises.

b. An electrical pulse, generated by the Dragon tracker's firing mechanism, activates the LES control box electronics. This supplies current to the glow plug inside the launcher. The glow plug

ignites the MAPP and oxygen gas mixture. An electronic time delay is incorporated in the LES control box electronics to simulate the delay between trigger squeeze and launch.

c. The LES control box (Figure 6-10) case assembly consists of two sections. The top section (cover) provides hose and cable storage space. The bottom section (base) contains the LES control panel, electronics assembly, battery pack, and MAPP gas and oxygen bottles and their respective regulators.

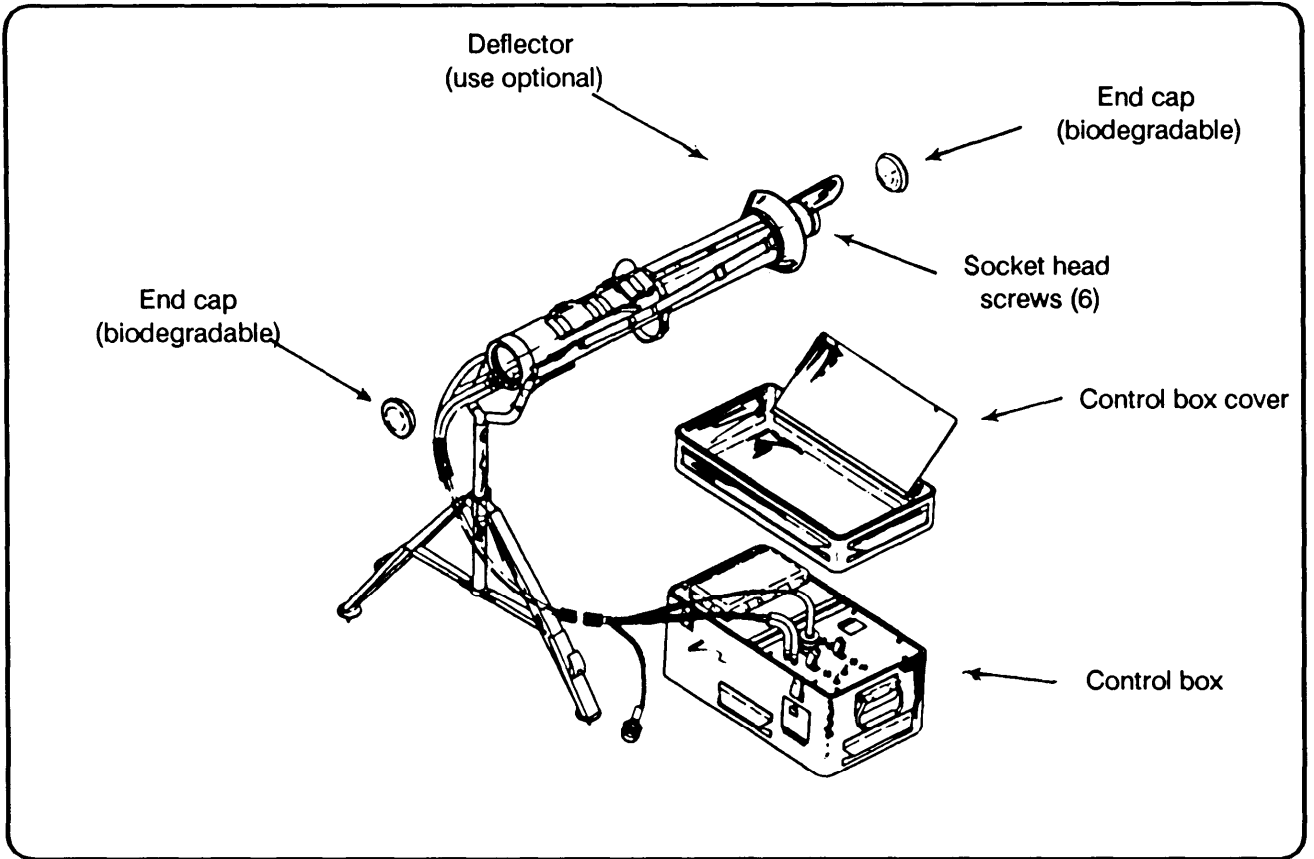

Figure 6-10. LES components.

Section II. INSTRUCTOR TRAINING

Once selected by the commander, the instructor must pass the performance test in Appendix B and

know the training objectives in this section. When he becomes proficient in the use of the training

equipment, the instructor must know the principles outlined in Chapter 7.

6-6. TRAINING OBJECTIVE 1

TASK: Prepare an AN/TSQ-1 monitoring set for operation.

NOTE: LET support stands are produced by the local TSC.

CONDITIONS: On a suitable range or training site, given one or more

monitoring sets, LET or LES training devices, LET support stands, and TM 9-6920-484-12 or NAVTRADEV P-6054.

STANDARDS:

1. Perform a preoperational check before operating the monitoring set

IAW TM 9-6920-484-12 or NAVTRADEV P-6054.

2. Replace any set that does not pass the voltage test IAW NAVTRADEV P-6054.

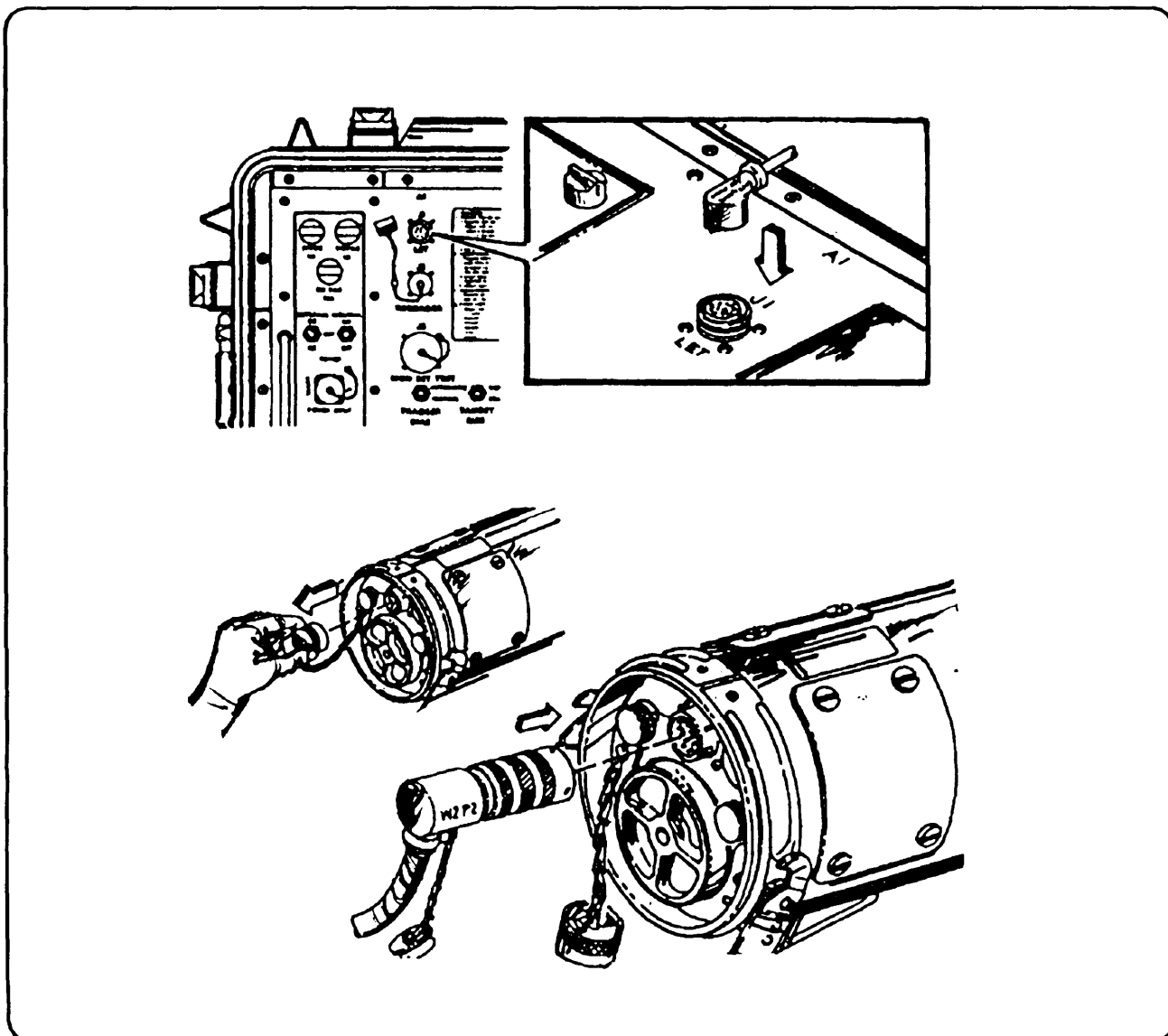

Figure 6-11. Mating the W2 cable assembly to the monitoring set and LET.

3. Mate the W2 cable assembly to the monitoring set and LET IAW TM 9-6920-484-12, (See Figure 6-11.)

4. Mate the LES to the monitoring set IAW NAVTRADEV P-6054. (See Figure 6-12.)

PERFORMANCE MEASURES:

1. Perform a before-operation check. Perform a check before operating the monitoring set for the first time, or when assigned as the operator and it is the first operation of the day.

a. Make a visual inspection of the monitoring set for damage, loose components, and dirt.

b. Check the monitoring set for moisture.

c. Check the connectors and cables.

2. Position the monitoring set at the firing site. Place the monitoring set 6 meters from the firing position when using the LET or LES.

3. Prepare the monitoring set for the voltage test.

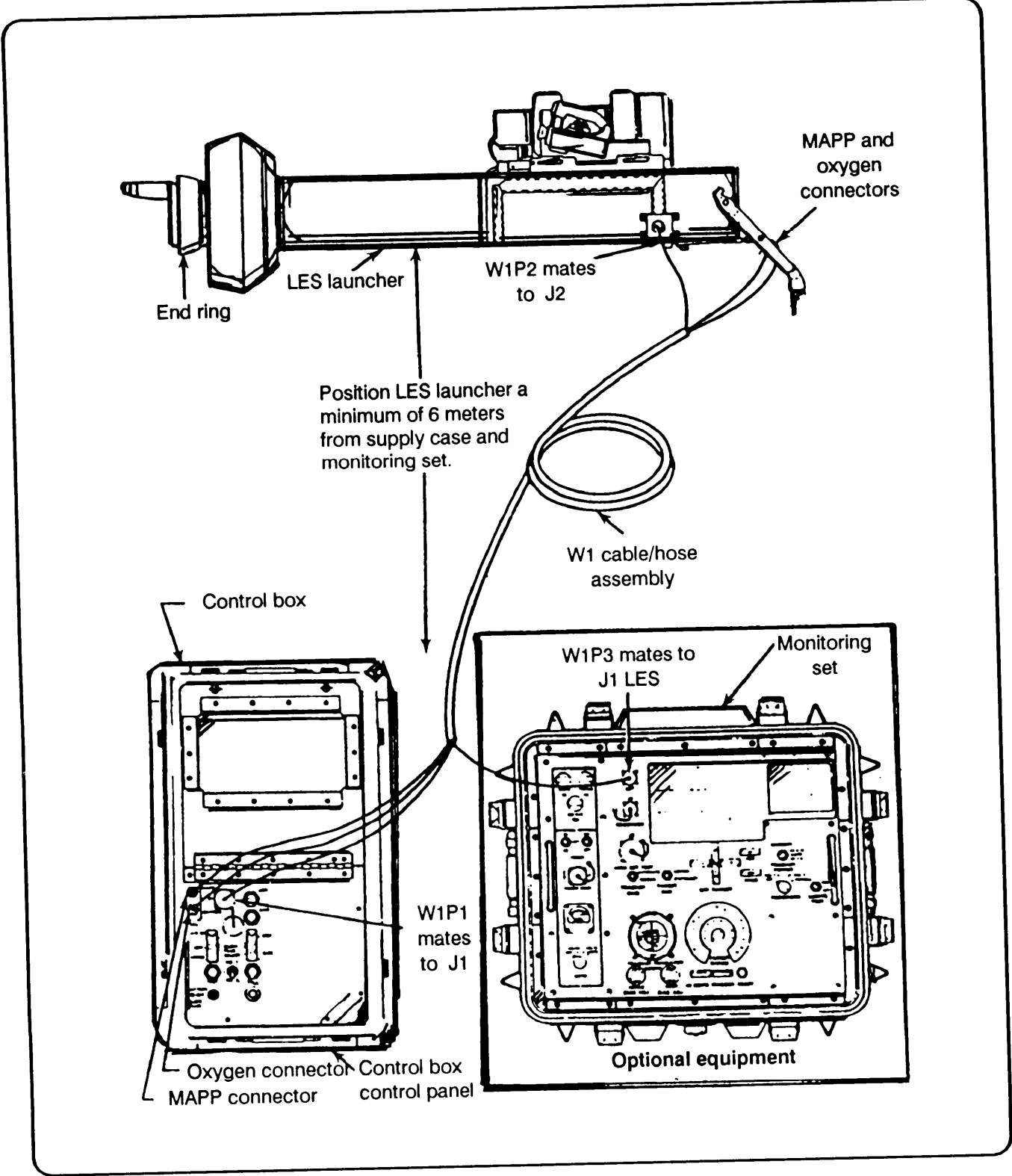

Figure 6-12. Mating the LES to the monitoring set.

4. Conduct the voltage test (Figure 6-13).

5. For the LET, connect the W2 cable assembly to the monitoring set and LET. For the LES, see Training Objective 7, Prepare/Operate a LES, and NAVTRADEV P-6054 for instructions on connecting the LES to the monitoring set.

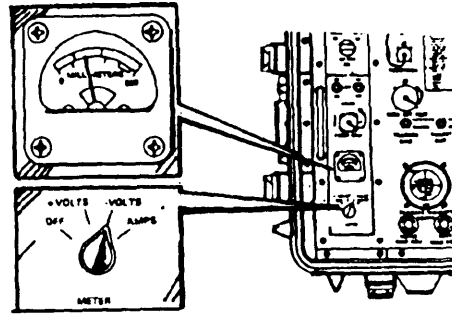

Figure 6-13. Conducting voltage test.

6-7. TRAINING OBJECTIVE 2

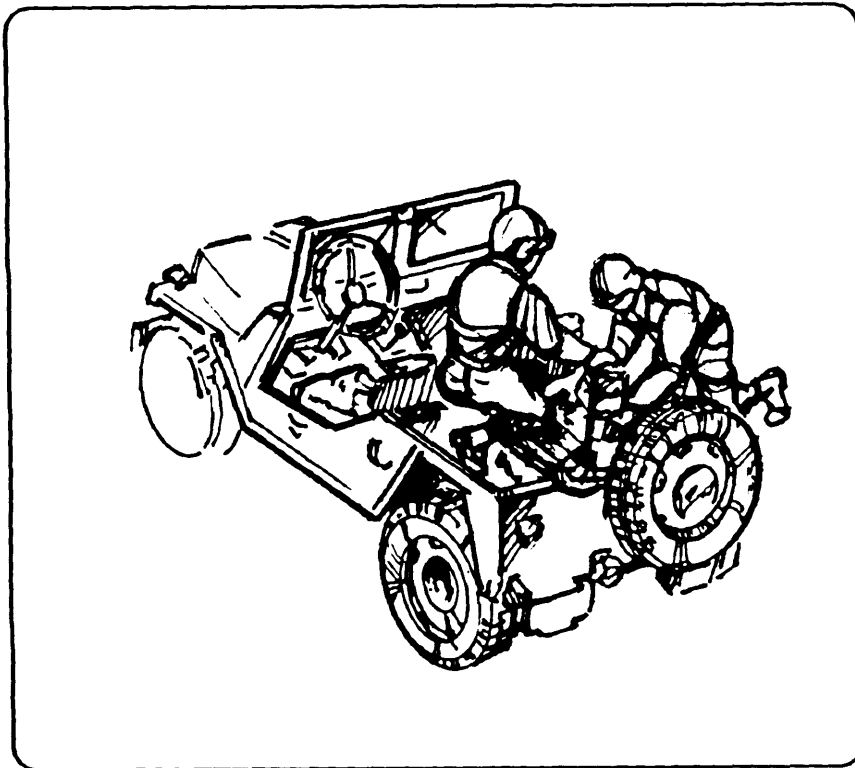

Figure 6-14. Mounting and securing the pedestal.

TASK: Install an M89 infrared transmitting set on a target vehicle.

CONDITIONS: Given an infrared transmitting set with all components; automotive tool kit; M151 1/4-ton truck, M113 APC, M561 Gamma Goat, or HMMWV 1 1/4-ton truck; TM 9-6920-484-12; and an assistant.

STANDARDS:

1. Mount and secure the pedestal on the vehicle (Figure 6-14).
2. Retain or turn in all parts and assemblies removed from the vehicle.

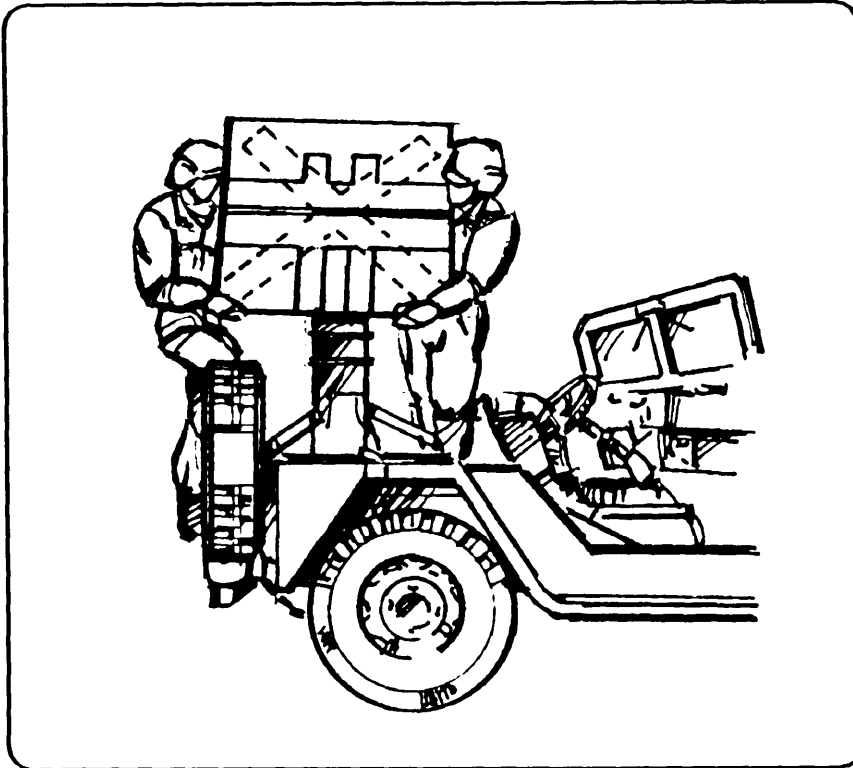

Figure 6-15. Installing and securing target board.

3. Install and secure the target board to the pedestal mount. (See Figure 6-15.)

4. Ensure all the cable routings are correct and connected to the correct component (Figure 6-16.)

FOR TOW HMMWV:

1. Install and secure the target board to the traversing unit mount.

2. Ensure all the cable routings are correct and connected to the correct component.

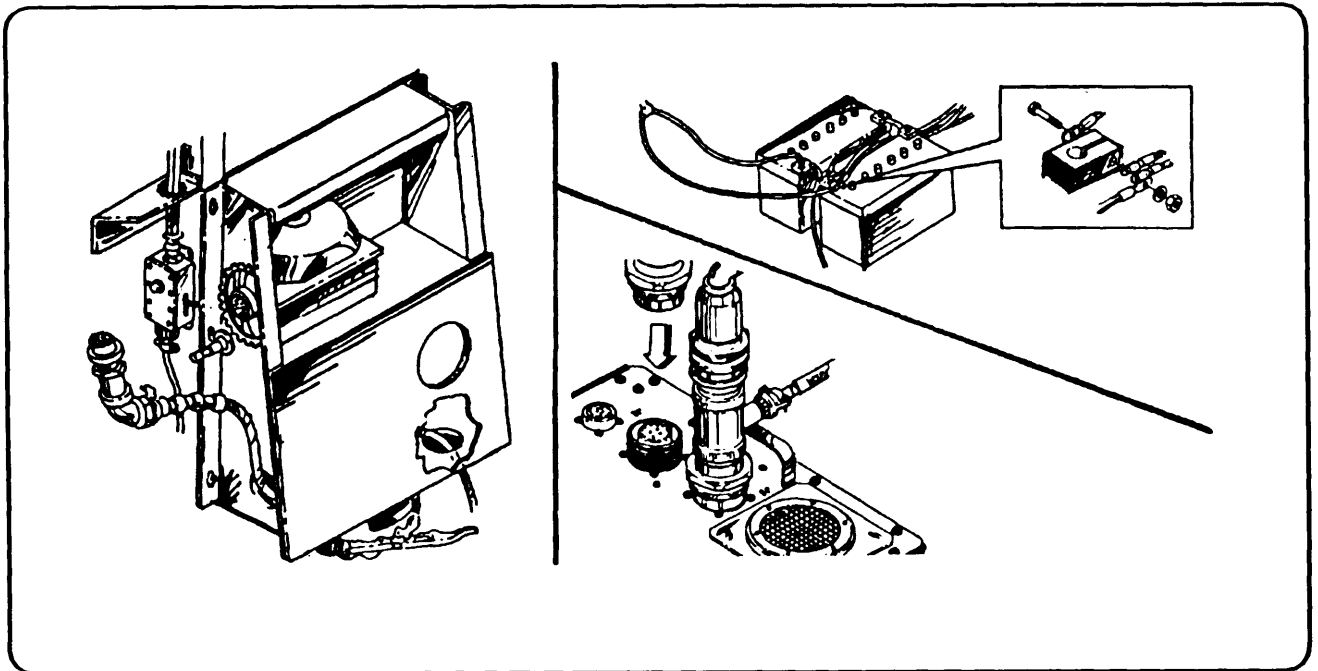

Figure 6-16. Ensuring cable routings are correct.

PERFORMANCE MEASURES:

CAUTION: To avoid damage to the adapter or pedestal, be sure that the three locking assemblies are disengaged and the locking pins are not protruding into the interior of the pedestal.

1. Mount the pedestal on the universal adapter plate using the

eight bolts, flat washers, lock washers, and nuts IAW TM 9-6920-484-12.

- 2. Place the pedestal assembly on the vehicle.
- 3. Strap the pedestal assembly to the vehicle.
- 4. Install the target board.

5. Hook up the infrared transmitter cables.

CAUTION: When connecting battery cable, do not short battery terminals to metal parts of the vehicle. Arcing can occur.

- 6. Install the power supply/modulator.
- 7. Apply power to the infrared transmitter.

6-8. TRAINING OBJECTIVE 3

TASK: Operate an M89 infrared transmitter.

CONDITIONS: Given an M151 1/4-ton truck or HMMWV 1 1/4-ton truck as a target vehicle, an infrared transmitting set with target mounting kit installed on the vehicle, and TM 9-6920-484-12.

STANDARDS:

- 1. Ensure that the infrared transmitter is installed on the target vehicle IAW TM 9-6920-484-12.
- 2. Perform a preoperational check before operating the infrared transmitter IAW TM 9-6920-484-12.

WARNING: Do not allow personnel to enter the danger zone while the target source is operating. Do not look at the target source through vehicle mirrors or any other reflecting source.

- 3. Do not allow personnel to enter the danger zone (see Figure 6-9) while the target source is in operation.
- 4. Start the power supply/modulator IAW the TM.

- 5. Operate the infrared transmitter IAW commands from the firing line.
- 6. At the end of the training session, perform maintenance on the infrared transmitter IAW the TM.

PERFORMANCE MEASURES:

1. Perform a before-operation check. Before operating the transmitter for the first time or when assigned as an operator and it is the first operation of the day.

CAUTION: Ensure that the face of the target board is away from the gunner and other personnel before starting the power supply/modulator.

- 2. Prepare the vehicle.
- 3. Check the target board. Check the target board mounting on the pedestal. Ensure that the adjusting clamp and locking assemblies are engaged.

CAUTION: Lamp cover must be removed before operating the power supply/modulator.

4. Prepare the power supply/modulator.

CAUTION: To prevent damage to the high-voltage power supply, do not hold the lamp start switch in the UP position for more than 15 seconds.

- 5. Prepare the target board for night training.
- 6. Operate the target board.
 - a. Turn the target board so that it faces the firing line.
 - b. At the end of each run, use the adjusting clamp to turn the target board so that it faces the firing line.
 - c. Turn on the radio and receive commands from the firing line.
- 7. Turn off equipment.
- 8. Use safety precautions when disconnecting the infrared transmitter.
 - a. Ensure that POWER circuit breaker is off before disconnecting cables.
 - b. Ensure that the transmitter is properly installed and secured before moving the target vehicle.
 - c. Shut down the transmitter immediately if the vehicle engine

stalls when the transmitter is in operation.

d. Periodically check the tie-down straps for tightness when operating the vehicle.

9. Maintain the infrared transmitter.

6-9. TRAINING OBJECTIVE 4

TASK: Conduct/perform equipment alignment.

CONDITIONS: Given the following equipment, set up for operation at a training site: monitoring set, infrared transmitter, LET or LES, two radios, LET support stand, TM 9-6920-484-12 or NAVTRADEV P-6054, and the following personnel:

- Monitoring set operator.
- Gunner.
- Loader.
- Infrared transmitter operator.

STANDARDS:

1. Align the monitoring set IAW the TM.
2. Train each soldier to perform assigned functions within the performance measures.

NOTE: Weather conditions and target source lamp age affect the maximum range at which the

tracker will receive the infrared transmitter signal.

PERFORMANCE MEASURES:

1. Deploy the infrared transmitter to the range at which the training exercise is to be conducted at 250 meters.
2. Establish communication between the monitoring set operator and infrared transmitter operator.
3. Have the monitoring set operator prepare the monitoring set for alignment.
4. Have the loader place the support stand under the rear of the LET.
5. Have the gunner perform zeroing procedures.

WARNING: Do not place an M64 NATO grenade launching cartridge in the LET during monitoring set zeroing procedures.

CAUTION: Minimize time in which the tracker power switch is in the (R) 4-10 position (not more than thirty seconds) to prevent damage to the tracker.

6. Have the monitoring set operator align the monitoring set.
7. Have the monitoring set operator, gunner, and loader verify that the LET and monitoring set are aligned.
8. If conducting a training exercise right away, have the monitoring set operator push the RESET switch.
9. If not conducting a training exercise right away, have the monitoring set operator —
 - Ž Set the INTERNAL POWER switch to the OFF position.
 - Notify the infrared transmitter operator to turn the infrared transmitter off.

6-10. TRAINING OBJECTIVE 5

TASK: Prepare/operate a LET.

CONDITIONS: On a firing range, given a LET, LET support stand, 16 BA-30 or W-B-101 batteries, flat-blade screwdriver, LET cleaning equipment, day or night tracker, gunner and loader, and TM 9-6920-484-12.

STANDARDS:

1. IAW the TM, the gunner must —
 - Extend and secure the biped.
 - Install 16 BA-30 or W-B-101 batteries into the LET.
 - Install either a day or night tracker on the LET.

- Ž Inform the monitoring set operator when to connect the W2 cable.
- Ž Maintain a steady track of the target by keeping the tracker optical sight cross hairs on the point of aim throughout the exercise.

2. Within 20 seconds and IAW the TM, the loader must –

- Ž Reset the dummy weight to the rear.
- Ž Open the breech and remove the expended cartridge.
- Ž Insert a new cartridge.
- Ž Close the breech, check the backblast area, and raise the safety lever to the ARM position.

PERFORMANCE MEASURES:

1. Have the gunner prepare the LET for operation.

WARNING: The monitoring set operator, gunner, and loader must wear ear protection.

WARNING: The M64 NATO grenade launching cartridge must be used in the LET. No other type of cartridge is authorized.

2. Have the loader reset the dummy weight. When the breechblock is open, the cartridge extractor positions the cartridge for manual removal. If unable to remove

cartridge by hand, use the flat-blade screwdriver located in the cleaning brush handle to aid in removal, then clean the chamber.

WARNING: Always reach for the breechblock lever from the top. Keep hands clear of rear exhaust ports to prevent injury from possible backblast.

- 3. Have the loader load the LET.
- 4. Have the loader arm the LET. Raise the safety lever to the UP position and tell the gunner that the LET is ready to fire.
- 5. Have the loader unload the LET in any of the following situations:

WARNING: Do not leave an expended cartridge in the chamber.

- a. End of exercise. Open the breech. Remove the spent cartridge and dispose of it according to local SOP. Close the breech.
- b. Mission abort. Open the breech, Remove the cartridge and replace it in its package. Close the breech.

WARNING: A misfire is considered a hangfire until it is determined otherwise.

c. Hangfire/misfire. The gunner notifies the monitoring set operator that a hangfire is in progress and points the LET downrange for 60 seconds. Then, the gunner unloads the M64 cartridge.

WARNING: In case of a misfire, the gunner should keep the LET in the firing position until the loader unloads the cartridge. If the primer cap is dented, notify the instructor. Refer to TM 9-1300-206 for disposition instructions. If a misfire occurs in which the primer explodes but fails to ignite the powder charge, the pressure chamber must be cleaned before the LET is used. For misfires that are not caused by malfunction of the firing mechanism, notify the ammunition supply point.

6. Have the gunner track and engage targets.

6-11. TRAINING OBJECTIVE 6

TASK: Conduct a LES system checkout.

CONDITIONS: Given LES equipment set up for operation and NAVTRADEV P-6054.

STANDARDS:

1. CONTROL BOX switch indicators give correct indications

when placed into operation IAW the TM.

2. Training equipment passes the leak test, or it is replaced IAW the TM.

3. IAW the TM, gas and oxygen lines are purged twice at the beginning of the training exercise.

PERFORMANCE MEASURES:

WARNING: The LES launcher is charged and ready to fire after step 6 is performed.

1. Set the control box switches.

WARNING: Explosive gases are being used. Ensure there are no open flames, sparks, or sources of ignition from the operating area.

2. Perform the control test procedures.
3. Conduct a leak test.
4. Purge the gas and oxygen lines.
5. Install end caps.
6. Press FILL button and arm.

6-12. TRAINING OBJECTIVE 7

TASK: Prepare/operate a LES.

CONDITIONS: On a suitable firing range, given a LES training device in its shipping container, monitoring set, charged oxygen and MAPP bottles, 1 1/8-inch open-/closed-end wrench, launcher support stand, NAVTRADEV P-6054, and the following personnel:

Ž Monitoring set operator.

- Gunner.
- Loader.

Ž Infrared transmitter operator.

STANDARDS:

1. Prepare the LES for operation IAW the TM.

NOTE: The instructor conducts a preoperational inspection of the LES control box and launcher.

2. The LES passes the system checkout IAW the TM.
3. The gunner performs immediate action for a misfire.

PERFORMANCE MEASURES:

1. Have the gunner prepare the LES launcher for operation.
2. Have the loader prepare the LES control box for operation.

- a. Place the control box 6 meters (20 feet) from the LES launcher.
- b. Install a charged MAPP bottle.
- c. Install a charged oxygen bottle.
- d. Connect the cable/hose assembly.

WARNING: The monitoring set operator, gunner, and loader must wear ear protection.

3. Have the gunner assume a firing position with the LES.
4. Have the loader prepare the launcher.
5. Have the monitoring set operator prepare the monitoring set.
6. Have the infrared transmitter operator prepare the transmitter set.
7. Have the loader depress the FILL switch and release.

NOTE: Steps 8, 9, and 10 should be performed within 15 seconds after performing step 7.

WARNING: Explosive gases are being used. Ensure there are no open flames, sparks, or sources of ignition from the operating area.

8. Have the loader conduct a test fire and notify the gunner that the LES launcher is ready.

TRAINING NOTE: Ambient temperature and humidity affect LES firing performances. Optimum firing results in the end cap being fragmented, thereby dispersing flour. Set the regulators initially at 16 psi MAPP and 46 psi oxygen, and perform a test fire. If the end caps are shattered, the mixture is correct. If the end caps are expelled intact and an orange flame is observed (indicating fuel rich condition), reduce the MAPP gas setting while holding the oxygen setting constant to a minimum of 14 psi. If still rich, increase the oxygen pressure to a maximum of 50 psi. To reset regulators to a lower pressure, turn the regulator control full counter-clockwise, remove both end caps, depress the FILL switch, install end caps, adjust regulators to new pressure, and proceed to STEP 5.

9. Have the gunner track and engage targets.

NOTE: To repeat the firing exercise, have the loader install new end caps.

WARNING: Before subsequent firings, ensure there is no glowing residue from end caps near either end of the LES launcher tube.

WARNING: Do not allow any part of the body to extend in front of or behind the LES launcher while performing the following steps.

10. Have the gunner perform immediate-action procedures. If a NO FIRE occurs (gases fail to ignite) apply immediate action as follows:

a. Waits five seconds and squeezes the firing mechanism again.

b. If the LES does not fire after the second attempt, the instructor immediately sets the ARM-SAFE switch on the control box to SAFE.

(1) Sets PWR ON-OFF-CHARGE switch to OFF.

(2) Removes both end caps from the launcher and allows a minimum of two minutes for the gases to vent.

(3) Unlatches and reseats the tracker.

(4) After two minutes, reinstalls both end caps.

(5) Sets PWR ON-OFF-CHARGE switch to ON.

(6) Performs BATTERY and GLOW PLUG tests. (See Training Objective 6, Conduct a LES System Checkout.) If the BATTERY TEST indicator does not illuminate, see Table 6-1. If the GLOW PLUG

circuit test does not illuminate, set the GLOW PLUG select switch to the alternate circuit and retest. If the light still fails to illuminate, see Table 6-1. Check the oxygen pressure.

(7) If all of the above indications are satisfactory, proceeds to STEP 5 of Table 6-1.

(8) If immediate action does not correct misfire, returns the LES to TSC for maintenance.

TRAINING NOTE: Table 6-1 lists the items most likely to fail during operation. Most failures cannot be corrected by the instructor. Replace the launcher or control box and notify the TSC or organizational maintenance of the failure when the equipment is turned in.

SYMPTOM	PROBABLE CAUSE	CORRECTIVE ACTION
1. No lights illuminate.	1. Dead battery. 2. Bad battery. 3. PI (panel) not mated with J2 (control box case). 4. Faulty PWR ON-OFF-CHARGE switch S2.	1. Notify TSC. 2. Notify TSC. 3. Notify TSC. 4. Notify TSC.
2. Individual lamp does not illuminate.	Bad lamp.	Notify TSC.
3. Battery does not charge.	1. Blown fuse. 2. Facility power not functional. 3. 115/230 switch in wrong position.	1. Notify TSC. 2. Notify TSC. 3. Reposition in switch to coincide with power source.

Table 6-1. Troubleshooting.

SYMPTOM	PROBABLE CAUSE	CORRECTIVE ACTION
	4. Faulty PWR ON-OFF-CHARGE switch S2. 5. Faulty battery.	4. Notify TSC. 5. Notify TSC.
4. Battery TEST function does not operate.	1. Discharged or faulty battery. 2. Faulty printed circuit card.	1. Charge battery. 2. Notify TSC.
5. GLOW PLUG TEST function does not operate.	1. Faulty glow plug or connectors. 2. Cable W1 not properly mated.	1. Notify TSC. 2. Check W1 connections for proper mate.
6. Glow plugs test good, but do not ignite gas.	1. Weak batteries. 2. Faulty firing pulse. 3. Faulty printed circuit card.	1. Test batteries. Charge batteries. 2. Reseat tracker.
7. Gas does not transfer when FILL switch is depressed.	1. Weak batteries. 2. Safety circuits will not reset. 3. Faulty printed circuit cards. 4. Faulty FILL switch.	1. Test batteries. Charge batteries. Notify TSC. 2. Briefly turn PWR to OFF, then back to ON. 3. Notify TSC/organizational maintenance. 4. Notify TSC/organizational maintenance.
8. Eight MAPP or oxygen does not transfer when FILL switch is depressed.	Fill valve malfunction.	Notify TSC/organizational maintenance.

Table 6-1. Troubleshooting (continued).

6-13. TRAINING OBJECTIVE 8

TASK: Conduct a training exercise.

CONDITIONS: Given a LET or LES (on an LET support stand), monitoring set, installed Dragon tracker, operational infrared transmitting set, two operational radios, M64 NATO grenade cartridges or LES end caps, flashlight for night training, TM 9-6920-484-12 or NAVTRADEV P-6054, and the following personnel:

Ž Monitoring set operator.

Ž Gunner.

- Loader.
- Infrared transmitter operator.

STANDARDS:

1. Select a site IAW the TM.
2. Operate the infrared transmitter IAW the TM.
3. Prepare the LET for operation IAW the TM.
4. Score and critique the gunner after each tracking run IAW the performance measures.

TRAINING NOTES:

1. Night training exercises require a flashlight to see the monitoring set panel.
2. When the monitoring set is operated with the TRACKER BIAS switch in manual, the TARGET RANGE switch must be set within one range segment of the actual target range. If the target range is changed more than one range segment, the monitoring set must be realigned IAW the equipment alignment check.

3. Operation of the training equipment for day and night training exercises is the same except for the sight pictures.

PERFORMANCE MEASURES:

1. Select a site.

NOTE: Before operating the training equipment, all personnel must refer to local regulations and SOPs for general safety precautions.

WARNING: The monitoring set operator, gunner, and loader must wear ear protection.

2. Prepare the monitoring set. Before conducting a training exercise, align the monitoring set.
3. Operate the infrared transmitter.
4. Prepare the LET or LES for operation. Ensure that the loader and gunner prepare the LET or LES for operation IAW Training Objective 5, Prepare/Operate a LET, or Training Objective 7, Prepare/Operate a LES; and the appropriate TM.

WARNING: Clear firing line to include checking the back-blast area.

5. Perform a training exercise.
 - a. Have the gunner assume either the sitting, standing supported, or kneeling position.
 - b. Turn on the monitoring set.

- c. Instruct the infrared transmitter operator (for moving target) to start the tracking run.

- d. Instruct the gunner to fire when the loader gives an UP signal.

- e. Have the monitoring set operator observe the monitoring set control panel after the gunner fires each round and during each tracking run for moving targets. The indicators show how well the gunner performed during each run.

6. Prepare and use the gunner's scorecard.

LINE 1. Identifies the gunner. Fill in all the blocks.

LINE 2. Circle weather condition. Place a check on the appropriate tracker used. Indicate which MOPP level is used (0 through 4). Mark obscuration if any type is used (smoke, dust, and so forth).

LINE 3. Check which type of position is used and if the fire table is for instruction or qualification.

7. Follow the examples on how to complete the scorecard (Figure 6-17 and Figure 6-18). Use DA Form 4242-R, Dragon Gunnery Scorecard, to score and critique the gunner. The blank, reproducible form is at the back of this manual. Gunner must fire both a sitting and standing supported table to achieve a qualification score (Appendix C).

8. Score and critique the gunner. See the following examples for use of the scorecard (Figure 6-17 and Figure 6-18).

EXAMPLE

The following is an example scoring exercise at 500 meters.

For a HIT, see STEPS 1 through 2.

For a MISS, see STEPS 3 through 8.

Indicate the vehicle direction by L-R or R-L (left to right or right to left)

or by drawing an arrowing pointing the way the vehicle was traveling.

STEP 1. The HIT indicator is lit, and an X is recorded in the hit column. The gunner's firing position is recorded. (See Figure 6-17.)

STEP 2. Check the score on the TRACKER INDICATOR SCORE meter.

a. Read the vertical (up and down) score by observing the position of the vertical score bar (the bar that runs across the meter) and by reading the number value directly underneath it. That number is written in the VERT column on the scorecard. (The example score is 85.)

DRAGON GUNNERY SCORECARD (CIRCLE ONE) I II III IV V VI

For use of this form, see FM 23-24. The proponent agency is TRADOC. DATA REQUIRED BY PRIVACY ACT OF 1974. Facilitates individual's training on targets at varying ranges. ROUTINE USE (S). Evaluate individual's proficiency. SSM is used for positive identification purposes only. MANDATORY OR VOLUNTARY DISCLOSURE AND EFFECT ON INDIVIDUAL NOT PROVIDING INFORMATION. Voluntary. Individuals not providing information cannot be reintegrated on a mass basis.

LAST NAME FIRST MI RANK SSM UNIT
 SMITH, JOHN J PFC 123-45-6789 A-1-13

WEATHER (CIRCLE ONE) FOG RAIN SNOW HAIL DAY TRACKER NIGHT TRACKER
 (CLEAR) MOHP LEVEL 0 OBSCURATION

SITTING STANDING SUPPORTED KNEELING PHONE MIXED
 M178 M122 M3 INSTRUCTION QUALIFICATION

TRACK	HIT	MISS	QUADRANT ERROR		METER SCORE		TARGET MPH	DIR	MONITOR SWITCH
			LEFT	RIGHT	UP	DOWN			
1	X				85	85	11	R-L	S
2									
3									
4									
5									
6									
7									
8									
9									
10									
11									
12									
13									
14									
15									
16									
17									
18									
19									
20									
TOTAL									

QUALIFICATION: 0-31 UNQUALIFIED 32-35 FIRST CLASS 36-40 EXPERT

DA Form 4242-R FEB 90

Figure 6-17. Example of completed scorecard of a HIT.

b. Read the horizontal (left and right) score by observing the position of the horizontal score bar (the bar that runs up and down) and by reading the number value directly underneath it. That number is written in the HORZ column on the

scorecard. (The example score is 85.)

STEP 3. The MISS indicator is on, and an X is recorded in the MISS column. (See Figure 6-18.)

a. The gunner's score is recorded on the scorecard using the TRACKER

INDICATOR SCORE meter. (See STEP 2.) (The example score is 75 VERT and 85 HORT.)

b. The gunner's firing position is recorded.

DRAGON GUNNERY SCORECARD (CIRCLE ONE) I II III IV V VI

Per use of this form, see FM 23-24. The procuring agency is TRADOC.
 DATA REQUIRED BY PRIVACY ACT OF 1974: Facilitates individual's training on targets at varying ranges. ROUTINE USE(S): Evaluate individual proficiency. SSN is used for positive identification purposes only. MANDATORY OR VOLUNTARY DISCLOSURE AND EFFECT ON INDIVIDUAL NOT PROVIDING INFORMATION: Voluntary. Individuals not providing information cannot be recorded on a mass basis.

AUTHORITY: 10 USC 3012(a)(6); Executive Order 12958; PRINCIPAL PURPOSE(S): Facilitates individual's training on targets at varying ranges. ROUTINE USE(S): Evaluate individual proficiency. SSN is used for positive identification purposes only. MANDATORY OR VOLUNTARY DISCLOSURE AND EFFECT ON INDIVIDUAL NOT PROVIDING INFORMATION: Voluntary. Individuals not providing information cannot be recorded on a mass basis.

LAST NAME: OBENRUDER, WILLIAM R. FIRST MI: RANK: E-3 SSN: 123-45-6789 UNIT: A-1-13

DAY TRACKER: NIGHT TRACKER: X
 MOPP LEVEL: 0 OBSCURATION: PRONE: MIXED: QUALIFICATION: X

WEATHER (CIRCLE ONE): CLEAR FOG SNOW HAIL SITTING: STANDING SUPPORTED: X KNEELING: INSTRUCTION: METER SCORE: VERT: 75 HORZ: 85 TARGET: MPH: 11 DIR: 5 MONITOR SWITCH: 5

TRACK	HIT	MISS	LEFT	RIGHT	UP	DOWN	VERT	HORZ	MPH	DIR	MONITOR SWITCH
1		X	2	45	4		75	85	11	5	
2											
3											
4											
5											
6											
7											
8											
9											
10											
11											
12											
13											
14											
15											
16											
17											
18											
19											
20											

TOTAL: QUALIFICATION: 0-31 UNQUALIFIED 32-35 FIRST CLASS 36-40 EXPERT

SCORER'S SIGNATURE: _____ GUNNER'S SIGNATURE: _____ DATE: _____

DA Form 4242-R FEB 90

Figure 6-18. Example of completed scorecard of a MISS.

STEP 4. At the end of the run (500 meters, simulated), the monitoring set indicates a MISS, but OFF TARGET indicators are not lit. This means that the gunner was on target at 500 meters but off target at some other range. The TARGET RANGE knob is rotated counterclockwise to 4.

STEP 5. At 400 meters, the MISS indicator is still lit, but the UP and R OFF TARGET indicators are lit. This indicates the gunner was off-target, too high, and to the right of the target at that range. A 4 is

written in the UP and RIGHT columns of the scorecard (Figure 6-18). The TARGET RANGE knob is rotated counterclockwise to 3.

STEP 6. At 300 meters, the MISS indicator is still lit, but only the R OFF TARGET indicator is lit. This indicates the gunner was off the target to the right of the target at that range. A 3 is written in the RIGHT column of the scorecard (Figure 6-18). The TARGET RANGE knob is rotated counterclockwise to 2.

STEP 7. At 200 meters, the MISS indicator is still lit, but only the L

OFF TARGET indicator is lit. This indicates the gunner was off the target to the left at that range. A 2 is written in the LEFT column of the scorecard (Figure 6-18). The TARGET RANGE knob is rotated counterclockwise to 1.

STEP 8. At 100 meters the MISS indicator is still lit, but OFF TARGET indicators are not lit. This indicates the gunner was on target at that range. Nothing is recorded on the scorecard for this range.

6-14. TRAINING OBJECTIVE 9

TASK: Prepare an M113 APC for Dragon training.

CONDITIONS: Given a LET, monitoring set, Dragon tracker, M175 guided missile launcher mounted on an M113 vehicle, TM 9-6920-484-12, and TM 9-1425-484-10.

STANDARDS:

1. Install the LET in the M175 guided missile launcher using the same procedures as for installing a round IAW TM 9-1425-484-10.
2. Install a Dragon day tracker or night tracker on the LET IAW TM 9-6920-484-12.

3. Place the monitoring set on the ground and attach the W2 cable to monitoring set and LET.

PERFORMANCE MEASURES:

WARNING: Danger zone is the same as for ground-mounted LET training.

1. Prepare the training equipment for operation on an M113 (mounted).
2. Install the LET in the M175 mount using the same procedure as for installing a round.
3. Remove the end cap from the LET.

4. Place the monitoring set on the ground alongside the APC.

5. Ensure that the firing danger zone to the front and rear of the M113 is clear.

6. Check the M113 for the following before any firing exercise:

- a. Antennas are down and secured.
- b. Driver and cargo hatches closed.
- c. All equipment stored on top of vehicles is secured.
- d. All other loose equipment or debris is removed.

6-15. TRAINING OBJECTIVE 10

TASK: Prepare training equipment for movement.

CONDITIONS: Upon completion of a training session and with a requirement to return the

equipment to the unit or TSC; given LET or LES training devices, monitoring sets, day or night trackers, infrared transmitting set

installed on a vehicle, and the following personnel:

- Monitoring set operator.
- Gunner.

- Loader.
- Infrared transmitter operator.

STANDARDS:

1. When training with the LET, have the –

Ž Loader clear and clean the LET and replace the end cap.

Ž Gunner return the LET to the shipping container.

- Monitoring set operator disconnect all cables, and store cables in the monitoring set.

Ž Infrared transmitter operator disconnect all cables from power supply/modulator and secure the target board and lamp cover.

2. When training with the LES, have the –

Ž Gunner disconnect the W1 cable assembly from the LES and return the LES to the shipping container.

- Loader remove the oxygen and MAPP gas bottles, and disconnect and store the W1 cable assembly.

Ž Monitoring set operator perform the same duties as when training with the LET.

- Infrared transmitter operator perform the same duties as when training with the LET.

PERFORMANCE MEASURES:

1. Have the loader clear the LET and replace the end cap.

a. Opens the breech and removes any expended/unexpended cartridge, then closes the breech.

b. Removes batteries from the LET.

c. Cleans the LET.

d. Uses LET cleaning rod to reset the weight.

e. Replaces the end cap.

2. Have the gunner store the LET in the shipping container.

a. Disconnects the cable from the monitoring set to the LET, and replaces the dust cover on the LET connector.

b. Removes the day or night tracker and replaces the electrical receptacle cover on both the tracker and LET.

c. Sets the LET on its rear. Folds the biped and releases the biped brace. With one hand, holds the forward shock absorber on the forward end of the LET; with the other hand, holds the biped in a horizontal position.

d. Pushes down hard on the forward shock absorber and slowly lowers the biped until the forward shock absorber locks in place.

e. Ensures that the hooks of the biped engage the pins of the forward shock absorber by trying to lift the forward shock absorber.

f. Secures the biped to the launcher tube with bipod strap.

g. Returns the LET and the LET cleaning brush to the LET shipping container. Closes and secures the lid.

3. Have the monitoring set operator disconnect all cables, and store them in the monitoring set.

a. Places the following MONITORING SET switches in the OFF position.

(1) EXTERNAL.

(2) INTERNAL.

(3) METER.

(4) RECORDER.

b. Disconnects the following cables from the monitoring set and replaces each dust cover.

(1) J1 connector (LET connector).

(2) POWER INPUT.

c. Stores the cables in the monitoring set lid.

(1) Installs the long cables in the cover by winding them over the bungee cords and around the hooks.

(2) Installs the short cables in the center of the cover and secures them with straps.

(3) Secures all cables with the bungee cords.

(4) Closes and secures the lid.

d. Closes the monitoring set. Places the cover on the base and secures the eight latches.

4. Have the infrared transmitter operator disconnect all cables from the PSM and secure the target board and lamp cover.

a. Ensures that the CB1 switch (24-VDC 40A circuit breaker) on the PSM is in the OFF position.

b. Loosens the retaining nut, disconnects the following connectors from the PSM, and replaces the dust covers on connectors.

(1) W1P1 connector from the J2 connector.

(2) W2P1 connector from the W3J1 connector.

(3) W3P1 connector from the J3 connector.

CAUTION: Stow the PSM so that it is stable and cannot fall off the vehicle.

c. Stows the PSM.

(1) Closes and latches the cover on the PSM.

(2) Removes the vehicle safety strap from the handle of the PSM.

(3) Stows the PSM on the floor of the vehicle.

d. Secures the target board.

(1) Ensures that the adjusting clamp is locked.

(2) Ensures that the three locking assemblies are in the locked position.

(3) Replaces the target board lamp cover and secures it with the four latches by pushing in on each latch and turning to the right.

5. Have the gunner disconnect the W1 cable assembly from the LES and store the LES in the shipping container.

6. Have the loader remove the oxygen and MAPP gas bottles and disconnect and store the W1 cable assembly.

a. Purges the gas and oxygen lines.

b. Stores the cable/hose assembly.

WARNING: Do not remove connectors permanently installed on the launcher.

c. Removes the oxygen bottle.

d. Removes the MAPP bottle.

e. Secures the oxygen and MAPP bottles for travel IAW TSC SOP.

7. Have the monitoring set operator disconnect all cables, and store them in the monitoring set.

8. Have the infrared transmitter operator disconnect all cables from the PSM and secure the target board and lamp cover.

6-16. TRAINING OBJECTIVE 11

TASK Charge the monitoring set batteries.

CONDITIONS: Given a 24-VDC, 115-VAC, or 230-VAC power source, monitoring set with cables, and TM 9-6920-484-12.

STANDARDS: Charge the monitoring set batteries for 16 hours IAW the TM.

TRAINING NOTES:

1. The nickel cadmium batteries in the monitoring set, when fully charged and operated under normal conditions, provide 200 or more tracking runs before recharging is needed. They provide a minimum of 100

tracking runs under unusual conditions such as extreme weather.

2. Battery efficiency and operating time are reduced if partly discharged batteries are recharged needlessly.

3. When the temperature is from 54 to 110 degrees Fahrenheit (from 12 to 43 degrees Celsius), 16 hours of charging time is needed to bring batteries from a discharged state to a full charge.

PERFORMANCE MEASURES:

1. Charge the batteries if the meter needle on the monitoring set is in the lower one-third of the yellow band

when the METER switch is placed in the + VOLTS or - VOLTS position.

2. Prepare the monitoring set for battery charging.

3. Select the appropriate connecting power cable.

4. Set the EXTERNAL POWER switch to the correct position.

5. Set the METER selector switch to the AMPS position.

6. Check for charged batteries.

7. Perform shutdown procedures.

6-17. TRAINING OBJECTIVE 12

TASK: Perform operator maintenance on a LET.

CONDITIONS: Given a LET, cleaning rod, small-arms chamber brush, rags, soapy water, bucket, LET support stand, and TM 9-6920-484-12.

STANDARDS:

1. Conduct an inspection of the LET IAW the TM.
2. Clean the LET IAW the TM.
 - a. After 100 rounds, clean with a dry cleaning brush.
 - b. Clean the cartridge chamber with the cartridge chamber brush.
 - c. Disassemble and clean at the end of each day's operation.
 - d. Assemble and conduct an operation check.

PERFORMANCE MEASURES:

1. Conduct an inspection of the LET.
 - a. Inspect the external surface for accumulation of dirt, oil, grease, or other foreign material, and then clean. Inspect for punctures and dents.
 - b. Inspect shock absorbers for punctures, cracks, dents, and

distortions. Check rear shock absorbers for loose mounting pins.

c. Inspect the retaining strap and sling for rips, tears, and serviceability.

d. Unfasten the biped retaining strap, remove the forward shock absorber, and extend the biped legs. Ensure that there is no binding and that the forward brace locks in position. Ensure that the biped swivels 45 degrees to either side and realigns to the center position when released. Ensure that the friction brake locks at random positions. Ensure that the leg assembly extension foot mountings extend properly and lock at random positions.

- e. Place the LET on a support stand.
- f. Inspect the battery compartment.

(1) Inspect the battery access cover for security and seal. Remove the battery access cover and check for retaining cables.

(2) Inspect inside the battery compartment for corrosion on the battery contacts and battery tubes.

(3) Replace the battery access cover.

g. Check the thumbscrews for operation.

h. Inspect the tracker support assembly and connector for loose or missing mounting screws. Inspect the spring retainer clip for loose or missing rivets. Remove the tracker support electrical connector cover. Inspect the electrical connector for bent or broken contacts. Inspect the cover for cracks and replace electrical connector cover after inspection.

i. Remove and inspect the rear closure and end cap assembly. Check for blistered or chipped paint and for loose or bent studs. Inspect for punctures, cracks, and dents.

2. Disassemble the LET for cleaning.
3. Check and clean the receiver.
4. Extend the LET biped.
5. Remove, check, and clean the forward shock absorber.
6. Remove and clean the dummy weight.
7. Clean the pressure tube.
8. Reassemble the LET.
9. Conduct an operational check.

6-18. TRAINING OBJECTIVE 13

TASK: Conduct a preoperational inspection of MILES Dragon equipment.

CONDITIONS: On a suitable range or training site, given a complete MILES Dragon system and either TM 9-1265-368-10-1 or GTA 25-6-9.

STANDARDS:

1. Perform a preoperational inspection before operating the MILES Dragon IAW the TM.
2. Conduct the preoperational inspection IAW the TM.

3. Report any deficiencies.

PERFORMANCE MEASURES:

1. Check the battery box to ensure that it is serviceable and does not contain a battery.

2. Check the bipod legs that are folded under the device for carrying. Check to see that they can be adjusted for height and that the left leg is adjustable to compensate for the offset of the tracker.
3. Check the weapon's key receptacle in front of the tracker head.
4. Check the laser transmitter lens next to the weapon's key receptacle and the ROUNDS REMAINING display button immediately above it.
5. Check the gunner's optical sight in the tracker head.
6. Check the trigger mechanism on the side of the tracker head.
7. Check the rounds remaining display window in the rear of the tracker head. The MILES Dragon should have a stored basic load of four rounds.
8. Inspect the entire launch tube to make sure there is no obvious damage on the outside.
9. Check the ATWESS PULL-TO-ARM switch and the ATWESS firing chamber at the rear of the device.
10. Ensure that the MILES Dragon carrying strap is present.

6-19. TRAINING OBJECTIVE 14

TASK: Place a MILES Dragon system into operation.

CONDITIONS: On a suitable range or training site, given a complete MILES Dragon system that has had a preoperational inspection

conducted, and either TM 9-1265-368-10-1 or GTA 25-6-9.

STANDARDS: Place the MILES Dragon into operation IAW the TM.

PERFORMANCE MEASURES:

1. Insert a battery.
2. Check the ROUNDS REMAINING display (troubleshooting).
3. Check the laser transmitter.

6-20. TRAINING OBJECTIVE 15

TASK: Operate a MILES Dragon system.

CONDITIONS: On a suitable range or training site, given a complete MILES Dragon system prepared for operation.

STANDARDS: Safely operate a MILES Dragon system IAW TM 9-1265-368-10-1.

TRAINING NOTES:

1. The MILES Dragon has a maximum range of 1,000 meters and a minimum arming range of 65 meters. It has a fixed tracking time of seven seconds, regardless of the distance to the target. There is a one-second launch delay and six seconds of tracking. A firing light indicator is

in the ROUNDS REMAINING display window. This small red dot will appear as a round is fired. Keep the cross hairs on the target for 50 percent of the time or longer for the first four seconds of track time and 90 percent of the time or longer the last two seconds of track time. With a guided missile, the last two seconds of track time are the most critical.

2. If a HIT is obtained with a MILES Dragon, the probability of killing an APC is 98 percent and killing a tank is 76 percent. If the MILES Dragon is killed during the exercise, deactivate the MILES Dragon with the yellow key. This makes the MILES Dragon inoperable.

3. The assistant waits until after the gunner has acquired a target to load an ATWESS device. The assistant then checks the backblast danger zone before pulling the PULL-TO-ARM switch.

PERFORMANCE MEASURES:

1. Target range is 65 to 1,000 meters.
2. Tracking time is one-second delay six seconds for tracking.
3. Firing light indicator is checked for the remaining rounds.
4. Target tracking is 50 percent: four seconds; 90 percent: two seconds.
5. Probability of kill is APC, 98 percent; tank, 76 percent.

INSTRUCTOR'S GUIDE TO EFFECTIVE TRAINING

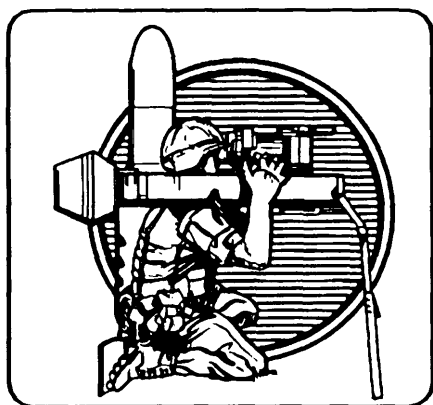

This chapter provides the instructor with the information needed to train and sustain Dragon gunners and to train soldiers as team members.

7-1. INSTRUCTOR SKILLS AND KNOWLEDGE

In addition to knowing the Dragon system, the instructor should know how the gunner learns, how the

gunner reacts to physical stimuli, the effects of physical and mental fatigue on gunner performance, and how to

recognize when this fatigue affects gunner performance.

7-2. TRAINING PROGRAM SCHEDULE

The training program for initially awarding the ASI of C2 requires 10 days and 235 tracking runs. The gunner also practices handling the weapon by training with an FHT. The number of gunners for each class is dictated by the number of equipped firing sites; that is, instructors, LETs or LESS, monitoring sets, and trackers, with four gunners to each site being ideal, six gunners for each site maximum,

and three gunners for each site minimum. This allows for the effective use of time.

a. Enough time must be allowed for equipment orientation training. Historically, negative results occurred when the training schedules were shortened. The more information provided to each soldier on how the weapon and training equipment operate and the purpose of each, the better the gunner.

b. Initial marksmanship training, institution or unit, teaches essential skills and develops fixed and correct procedures in marksmanship before range practice begins. Thorough instruction and carefully supervised practice in the initial phase saves time and ammunition during range firing and develops techniques and procedures necessary for well-trained Dragon gunners and teams.

7-3. INDIVIDUAL INSTRUCTIONS

Various skills and habits must be learned by each gunner to prepare for live Dragon firing. Although the Dragon training equipment closely simulates firing the Dragon weapon, it must be accompanied by personalized individual instruction. The instructor should key on the following points:

- a. Coach and stress the following gunnery techniques:
 - Tight eye contact with the eyecup.
 - Proper position.
 - Steady hold at the launch.

- Steady tracking at all times, especially through smoke.
- Slow and steady aim point correction to the target.

WARNING: Because of blast noise, the surgeon general has set a limit of LES firings to five firings for each student for each day. Rotate instructors daily on the firing points.

- b. Use and emphasize the sitting position and standing supported positions.

- c. Have gunners practice tracking in both directions – left to right and right to left.
- d. Limit training with the LET to 20 to 40 shots each day for each student (one or two firing tables) because of gunner fatigue.
- e. Record student progress and all LET or LES shots on the gunner scorecard.
- f. Have gunners clean the training equipment at the end of the day.

7-4. TRAINING AT 250 METERS

NOTE: Weather conditions and target source lamp age affect the maximum range at which the tracker will receive the infrared transmitter signal.

Training is conducted at one range – 250 meters. The difference in target dynamics at different ranges is simulated by varying the target speed and by the time span of firing exercises. This technique is unsatisfactory for developing steady

tracking capability and determining if the target is within range. Extra exercises, with targets at all ranges, must be conducted to inform gunners of the actual appearance of targets in the tracker.

7-5. TRAINING SEQUENCE

The Dragon gunner should be trained in the following sequence to control the missile launch and flight:
 Ž Positions.

- Sighting, aiming, and firing.
- Breathing.
- Tracking exercises.
- Qualification and verification. (See Tables 7-1 and 7-2 and Appendix C.)

7-6. FIRING POSITIONS DEMONSTRATIONS

The gunner must acquire and maintain a stable body position relative to the weapon and be able to move smoothly when tracking a

moving target. The round must be solidly anchored on the muscle of the gunner's shoulder. His arms and hands must be properly placed to

squeeze the trigger and to maintain the stability of the round. The position of the eye against the optical sight eyepiece is critical since it

lessens launch-induced movements and prevents obscuration. There are four basic firing positions for the Dragon: sitting, standing supported, kneeling, and prone. A modified sitting position is used when firing the Dragon from the M175 mount. The M175 mount can be used with the M3 or M122 machine gun tripod. These firing positions are demonstrated to the soldiers as follows:

a. **Sitting Position.** Demonstrate the sitting position, then have the soldiers assume the position (Figure 7-1).

(1) The sitting position is the most stable. Sit with the legs extended as far as possible. Place the notch of the boot heels on the biped and push outward.

(2) Lean forward at the waist as far as possible. Pick up the round and place it on the muscle portion of the shoulder, keeping it tight against the curve of the neck (Figure 7-2).

(3) Grasp the tracker barrel with the left hand, curling the thumb under

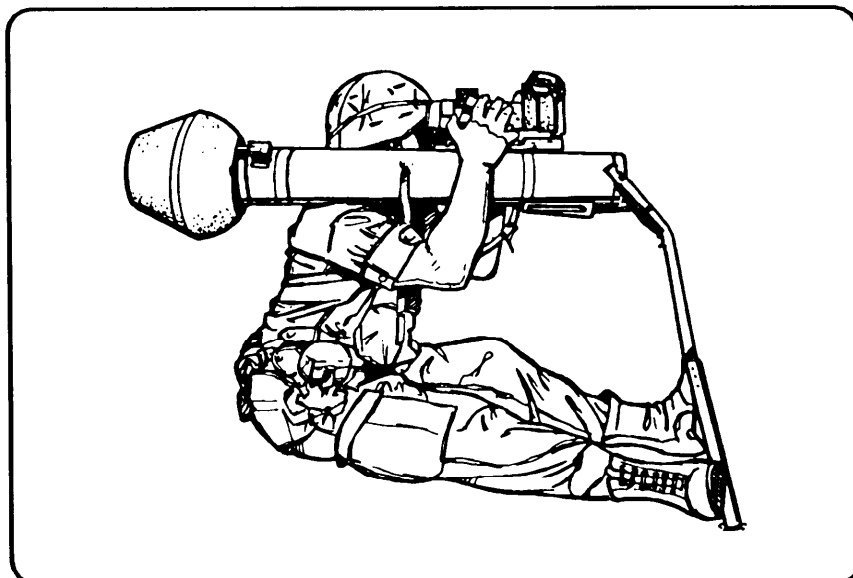

Figure 7-1. Sitting position.

the tube. Grasp the firing mechanism with the right hand, thumb on the safety, three fingers on the firing lever, and the little finger on the front of the firing mechanism. Place the heel of the hand on the base of the firing position to provide a firm grip and reduce slippage. When firing, hold the trigger in the depressed position; releasing the

hand causes involuntary muscle reaction and undesirable round and tracker motion.

(4) Lift the head to align the right eye with the telescopic sight. Press the head forward, then press the eye tightly into the eye guard since this forces the eye to stay open. Close the left eye and keep it closed. Focus the tracker, if necessary.

(5) Pull down and back with the hands while pushing out with the feet. Try to touch the elbows together and to the chest at the same time.

(6) Keep the back as straight as possible while leaning forward for better breath control. This limits discomfort and increases the ability to move the upper body.

(7) Maintain arm, back, and leg muscle tension. Use enough force so that involuntary muscle reaction does not occur because of the loss of the missile weight from the shoulder.

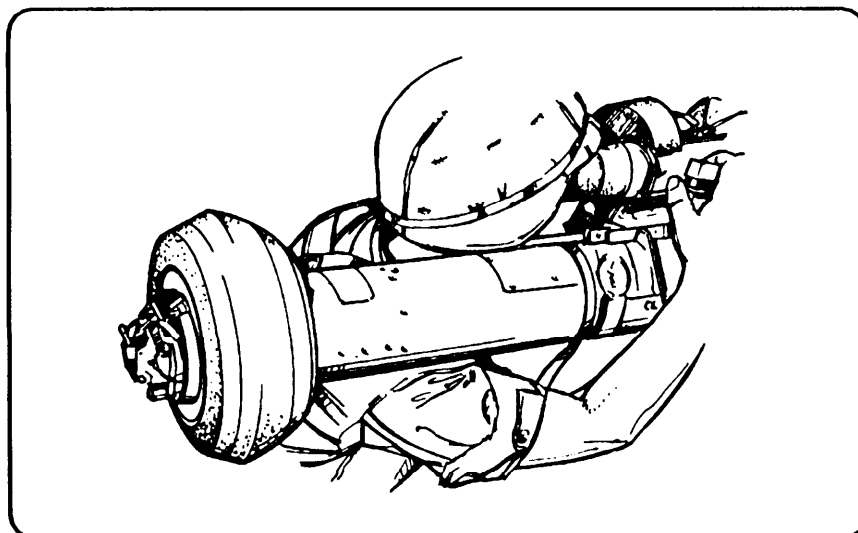

Figure 7-2. Positioning of round on shoulder.

b. Standing Supported Position.

Demonstrate the position, then have the soldiers assume it (Figure 7-3).

(1) Place the bipod legs to the front of yourself while standing in an individual fighting position or behind a support. The bipod is placed at such a distance that the gunner must reach for the round.

(2) Spread the legs a comfortable distance apart, keeping the legs straight. Place the round on the shoulder muscle.

(3) Lean forward against the fighting position's wall to support the body from the waist down, providing a stable firing position.

(4) Grip the tracker as in the sitting position. Pull back and down, while straightening the upper body slightly

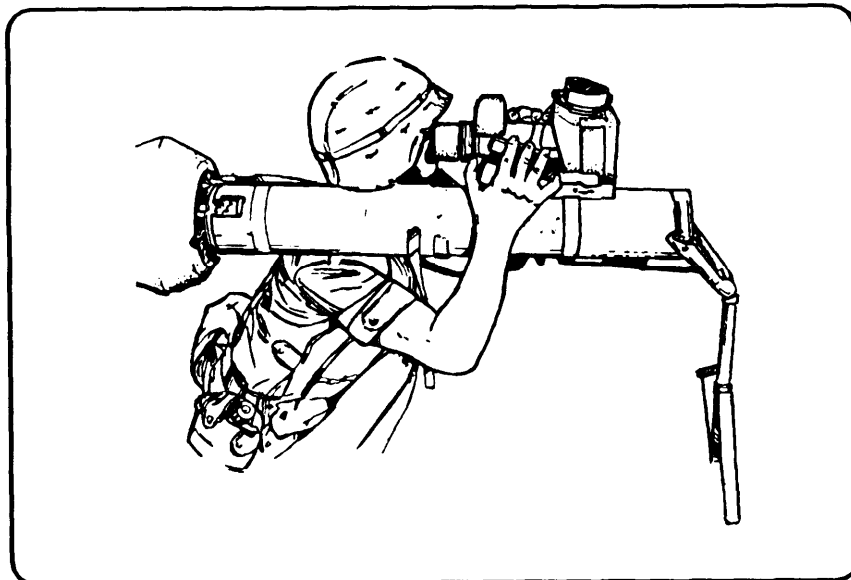

Figure 7-3. Standing supported position (fighting position).

since this removes any slack in the bipod.

(5) The upper body, arms, hands, head, and eyes are in the same position as in the sitting position.

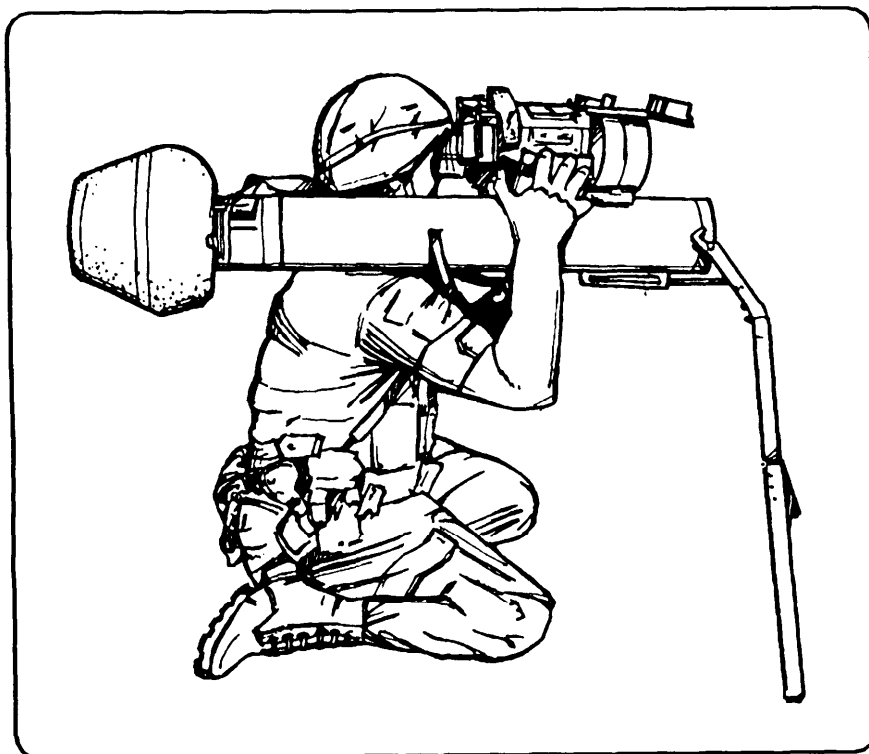

Figure 7-4. Kneeling position.

c. Kneeling Position. Demonstrate the position, then have the soldiers assume it (Figure 7-4).

(1) Kneel on both knees and spread them a comfortable distance apart. Position the bipod so that you have to lean forward to position the eye in the eye guard.

(2) Grasp the tracker as previously described. Maintain the same upper body position as in the other firing positions. Place the round on the shoulder muscle, keeping it tight against the neck (Figure 7-5).

(3) As the buttocks are lowered to the heels, take the slack out of the bipod. Try to sit on the heels to provide a stable platform for firing.

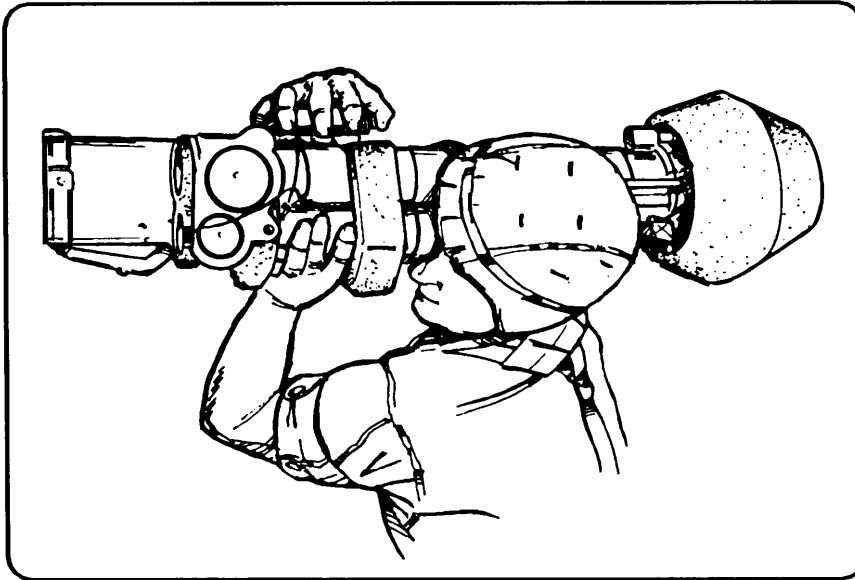

Figure 7-5. Correct eye and hand positions.

TRAINING NOTES:

1. Stress the need for keeping the pull down force on the tracker and the eye tight in the eye guard.
2. Body positioning and breath control are the two key elements to effectively engage targets.
3. The prone position is the least favorable position. It is difficult and uncomfortable to track moving targets in this position.
4. Ensure the gunner does not place any portion of his body in the backblast area. The round must be kept at least 6 inches off the ground to allow the missile fin's clearance.

d. **Prone Position.** Demonstrate the position, then have the students assume it (Figure 7-6).

WARNING: Firing from the prone position is not recommended. Firing the Dragon from this position places the gunner in danger from the backblast.

- (1) The round is ready to fire with the biped collapsed, the tracker mounted, and the front shock absorber removed. (Figure 7-7).
- (2) Place the body at a 90-degree angle to the launcher to remain outside the backblast area.
- (3) Lay the launcher across the right bicep with the biped on top of the bicep. Encircle the round with the right arm so the right hand can grasp the firing mechanism.

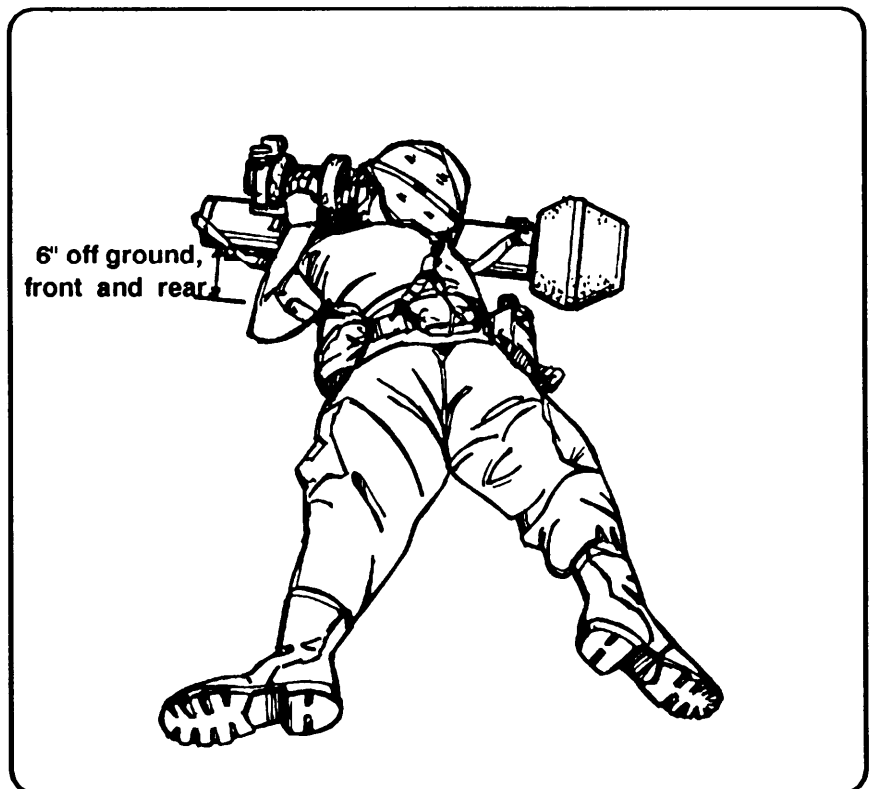

Figure 7-6. Prone position.

(4) Grip the tracker barrel with the left hand and pull the launcher tightly into the neck. (The launcher is pulled into the neck because there is no supporting biped.)

(5) Press the head forward, keeping the eye tightly in the eye guard.

(6) Use the forward shock absorber to rest the launcher's front on and provide a 6-inch ground clearance. Ensure that the shock absorber is not protruding in front of the muzzle.

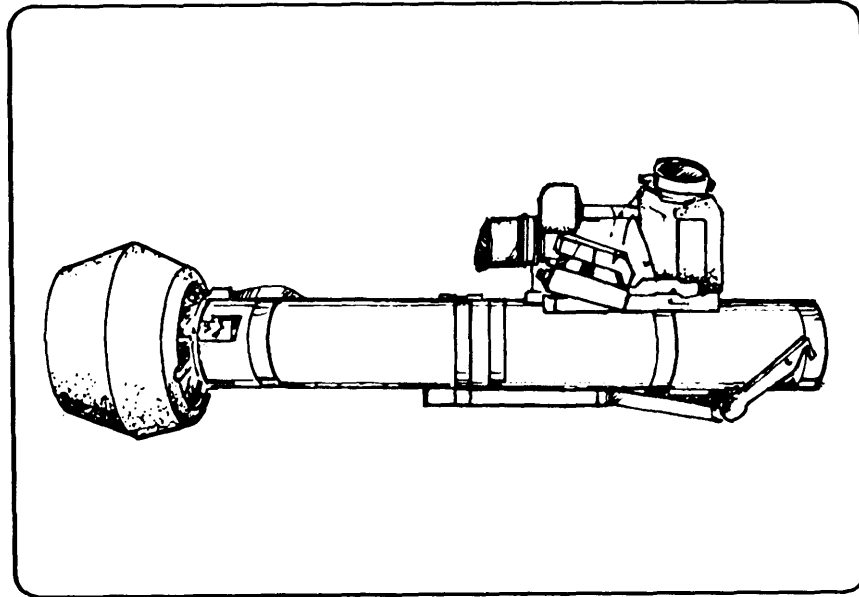

Figure 7-7. Prone firing configuration.

7-7. M113 INSTRUCTIONAL TECHNIQUES

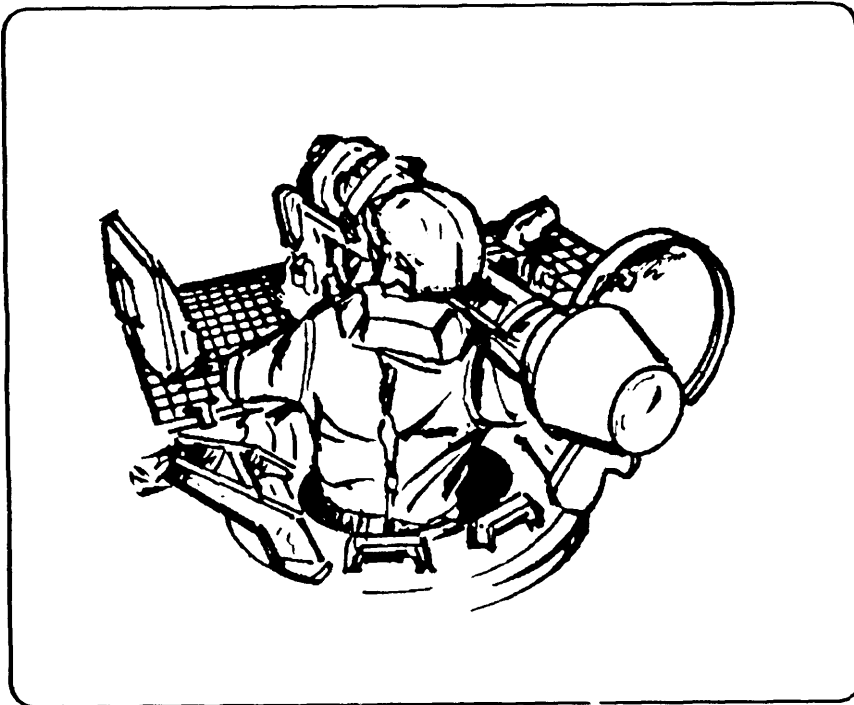

Figure 7-8. M175 firing position on APC.

The following instructional techniques apply only to M113-equipped units.

a. Demonstrate the M175 mount position on the APC, then have the soldiers assume the position (Figure 7-8).

CAUTION: When firing the Dragon while mounted on the m175 mount, the gunner must apply heavy rearward and downward pressure on the elevation damper to apply maximum downward force on his shoulder. This action helps prevent the weapon from dipping and flying the missile into the ground.

(1) Adjust the commander's chair in the APC so that when the gunner is in the firing position, both feet are flat on the chair with knees and body straight.

(2) Keep the feet apart at a comfortable angle.

(3) Ensure that the left arm and hand exert maximum rearward pressure on the elevation damper. This action pulls the cradle down against the gunner's shoulder (Figure 7-9).

(4) Position the right hand on the M175 mount firing mechanism the same as with the tracker firing mechanism: right thumb on safety; index, middle, and third fingers on the trigger lever; and the little finger forward of the trigger mechanism.

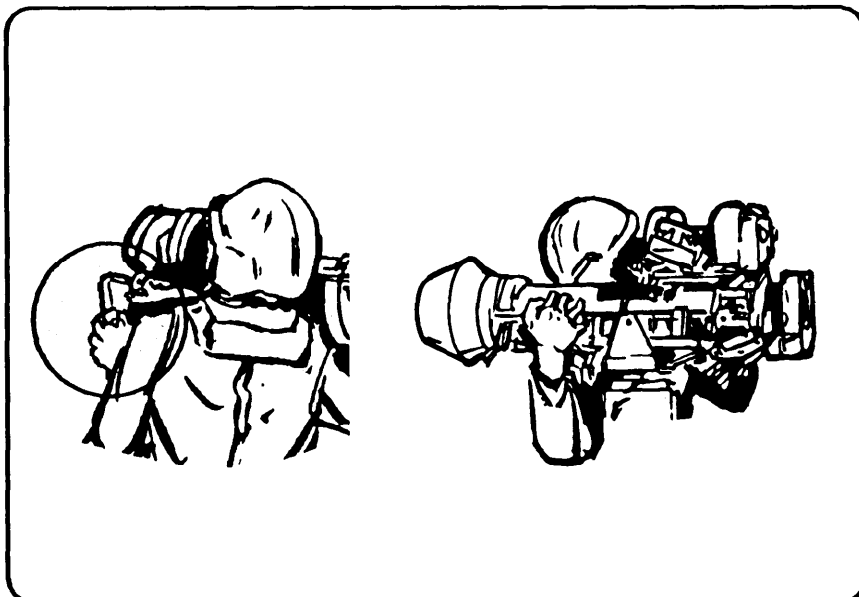

Figure 7-9. M175 firing position.

b. Demonstrate the position for the M3 or M122 tripods, then have the soldiers assume the position (Figure 7-10).

(1) *M3 tripod.* With the M3 tripod, the gunner sits along the left side of the tripod to ensure that no portion of his body is forward of the muzzle. Sight, aim, and fire the same as when mounted on an APC.

(2) *M122 tripod.* With the M122 tripod, put the right leg over the top of the two rear tripod legs. Put the left leg over the top of the front tripod leg. Sight, aim, and fire the same as when mounted on an APC.

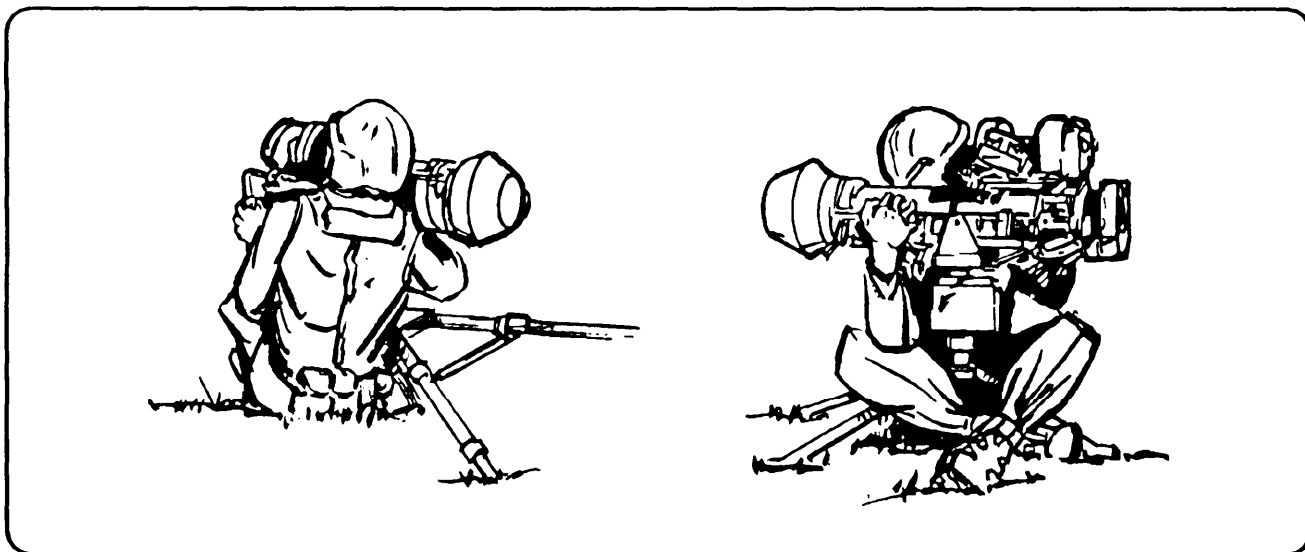

Figure 7-10. M3 or M122 tripod positions.

NOTE: Body position is the most important factor to successful firing and tracking. Continual

feedback to the soldiers during the early phase of practical

training helps to form good habits.

7-8. SIGHTING. AIMING. AND FIRING

The instructor tells the gunner to place the eye in the eyecup and pull the weapon tight enough into the eye so that he cannot blink. If held tight, the sight picture will not be lost during the launch; the gunner must not move the eye in the eyecup. If eye movement occurs, the prism side is seen instead of seeing through the prism in the telescope, which causes blurred vision the same as smoke and heat. This is demonstrated to each soldier.

a. Wrap the small finger around the front of the trigger housing to give added pulling force to place the weapon tight against the eye. Although the LET always gives rear recoil, the Dragon weapon sometimes gives forward recoil.

(1) Visually select a target and acquire it through the day tracker or night tracker by adjusting the upper portion of the body. Once the target is within range by using the stadia lines, place the cross hairs of the day tracker or night tracker on the center of visible mass of the target, keeping the cross hairs on one selected point until the missile is fired and impact is observed. Always keep the cross hairs of the tracker on one selected point of the target, whether it be a moving or stationary target. When tracking a moving target, move the upper portion of your body laterally to maintain the proper sight picture.

(2) Do not adjust the aiming point for range or speed; always place the cross hairs of the tracker on the

center of the target's visible mass. Concentrate on the aiming point. If distracted, target tracking becomes poor and reduces the chance of hitting the target.

b. When firing from the seated position, never rest elbows on the knees since leg movement is transferred directly to the tracker. The missile reacts to any movement sent by the tracker.

c. Ensure the safety is fully depressed before attempting to squeeze the trigger. Squeeze rather than pull the trigger. Since the weapon has little recoil, many gunners move more when they pull the trigger than when the missile is launched.

7-9. BREATH CONTROL

Aiming the Dragon is similar to aiming a rifle, except that the cross hairs must be kept on the desired impact point for 1 to 12 seconds following missile launch, depending on the target range. It is important to begin breath control two seconds

before the trigger is squeezed and to continue holding the breath throughout the target acquisition, firing, and tracking. This must be stressed during gunner training. To prevent breathing from interfering with tracking, the gunner takes a

breath, then holds the breathe while the trigger is pressed. He must not breathe while tracking a target since body movements cause the launcher to move. To check the gunner for breath control, the instructor observes the gunner's back.

7-10. TRACKING EXERCISES

The proper reaction to temporary obscuration is an important gunner skill. Occasionally, the target may be obscured by launch gases, dust, and so forth. The gunner's instinctive

reaction is to look for a target, causing erratic missile flight or flight termination. Training prepares the gunner to "freeze" on a stationary target or to continue tracking at the

established rate on a moving target until the target reappears. Instructors should introduce simulated obscuration during LET exercises. They should show soldiers

that improper reaction produces LOS excursions beyond the established aiming error limits. Most training should be conducted at moving targets to promote gunner concentration.

a. If a gunner can consistently hit a moving target, a stationary target can easily be hit. Most MISSES occur on moving targets. Training in tracking a moving target begins when

proficiency is attained in positions, sighting and aiming, and breathing.

NOTE: Concentration on moving targets is most beneficial to the gunner.

b. Tracking exercises should begin on a tracking range set up for the Dragon training equipment. In this training phase, the gunner performs a series of tracking exercises to understand the procedures needed

during the qualification and verification phases. When tracking the gunner tracks the center of the target board where the infrared transmitter is located. His progress is checked by using the monitoring set while he tracks stationary and moving targets. (For firing and scoring procedures, see Chapters 6 and 7 and Appendix C.)

7-11. RANGE REQUIREMENTS

Training with the Dragon training equipment does not require the use of a live-fire range since gunner training is performed without the use

of live missiles. All that is required is a firing line to allow for the LET or LES, one target vehicle, and a target vehicle tracking road that is running

parallel to the firing line (Figure 7-11).

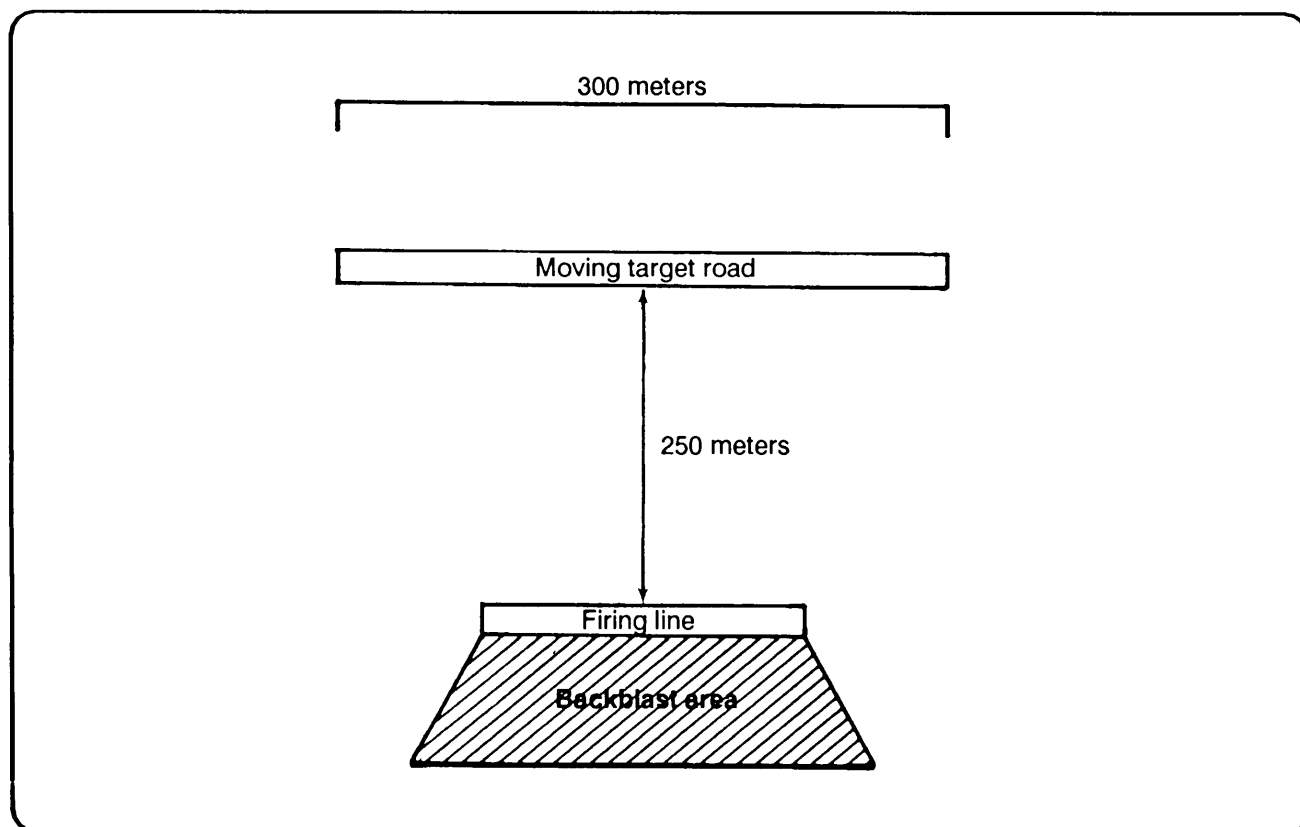

Figure 7-11. Target acquisition and tracking range.

a. The firing line should be level and allow for movement of the equipment to and from the firing line. It should be long enough to allow about 6 meters between each

LET or LES used during the training exercise. The backblast area should be 50 meters deep to accustom gunners to the 50-meter backblast area of the Dragon (Figure 7-12).

The distance from the firing line to the tracking road should be no more than 250 meters.

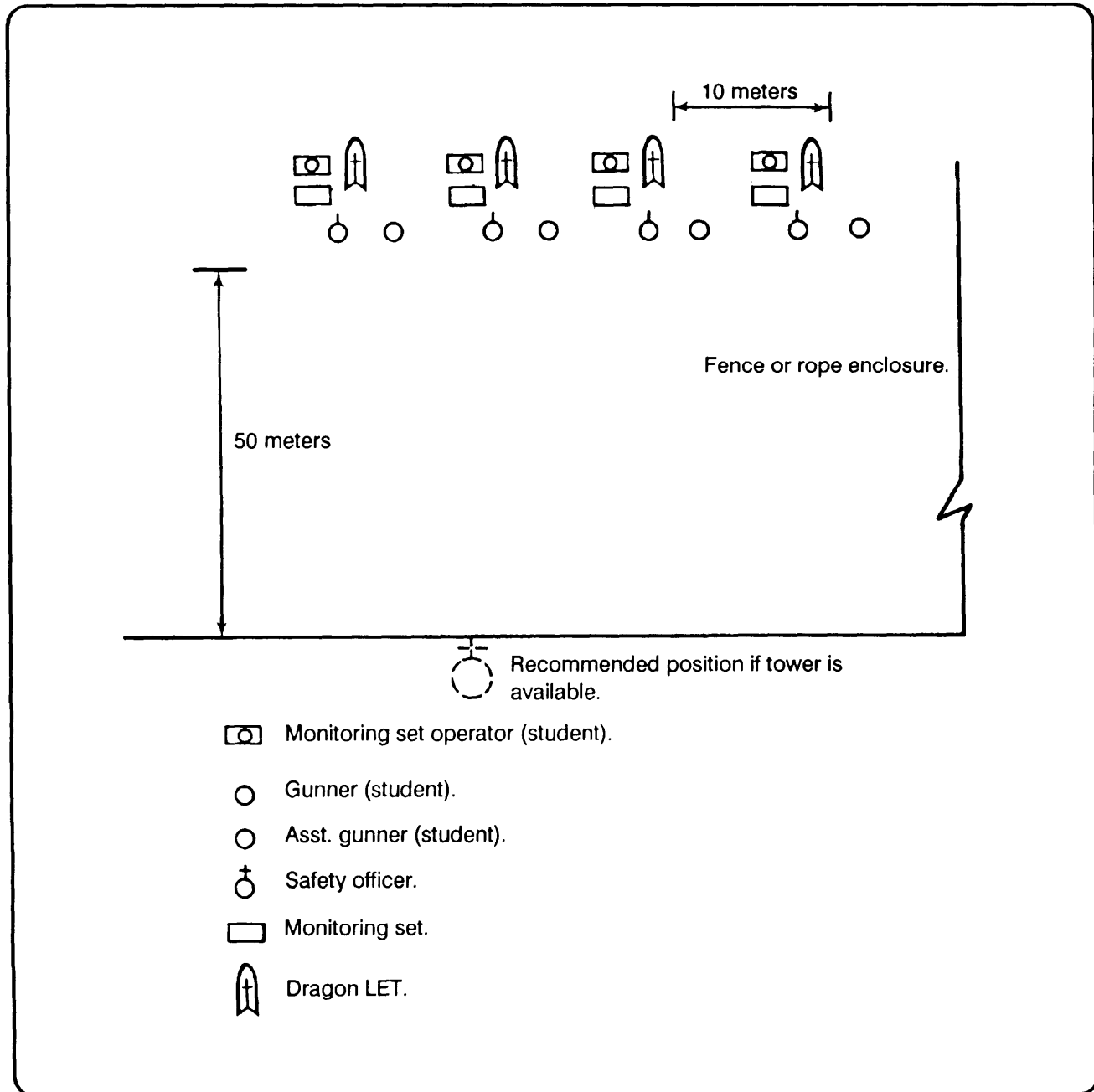

Figure 7-12. Firing line organization.

b. The target vehicle tracking road should be parallel to the firing line and at least 300 meters long. The longer road length allows a greater variation in tracking runs. It also allows the target vehicle to reach the needed tracking speed, to maintain the speed for the tracking time, and to stop safely. The road must be as smooth as possible. A rough road causes the target board on the target vehicle to vibrate, making it difficult for a gunner to keep the sight cross hairs on the target. The area between the firing line and tracking road must be clear of objects such as trees and brush. They break the infrared signal which is transmitted by the target set

to the tracker. A loss of signal may affect a gunner's score. A formal training range, abandoned airstrips, parade fields, DZs, open fields or valleys, range roads, and so forth, are good examples of temporary ranges that can be used.

c. The gunner's tracking rate is determined by the range to the target vehicle and the target vehicle's speed. The monitoring set target range permits time selection to correspond with simulated missile flight time to the selected target range. Most training exercises are conducted at a single target vehicle range (250 meters). (Other ranges

are simulated by the monitoring set.) The allowable error limits become smaller as the monitoring set range program sequences out to range segment 10 or maximum range.

d. Figure 7-13 is an example of the physical relationship of a tank at 250, 500, and 1,000 meters. That relationship is applied to the target board superimposed on the horizontal error limits of the monitoring set. A gunner must keep a tight aim point when the target vehicle is at 250 meters, and the monitoring set range program is simulating 500 or 1,000 meter ranges.

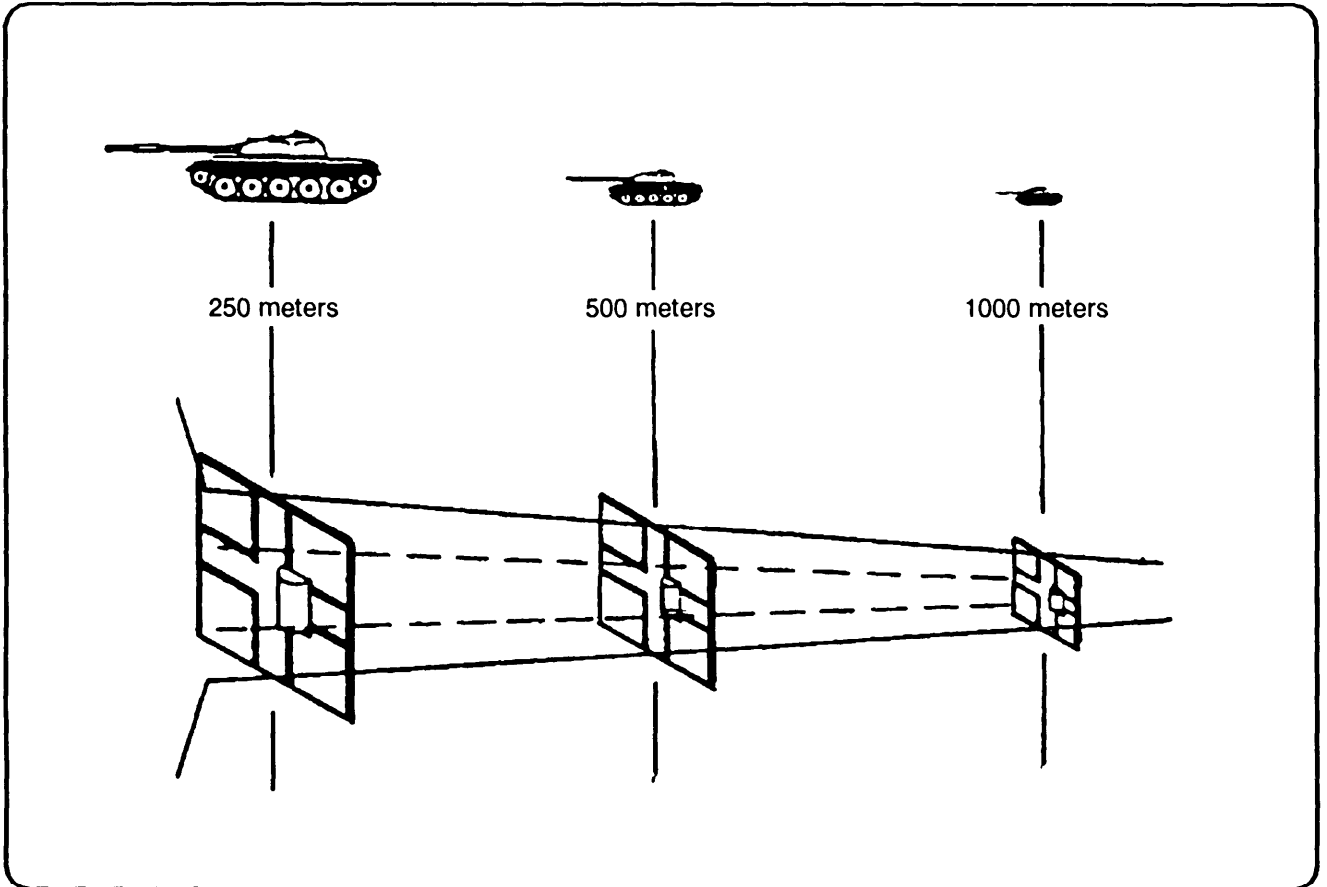

Figure 7-13. Physical relationship versus range.

e. The speed of the target vehicle is important when simulating target ranges (Figure 7-14). The tracker is designed so that a gunner can track a 35-kmph (22 mph) moving target across a 6-degree field of view.

f. As range increases, the distance across the 6-degree field of view increases, but the angle remains the same. If it takes 10 seconds for a vehicle moving at 35 kmph (22 mph) to move 6 degrees at 1,000 meters, then the same vehicle speed must be reduced proportionately when simulating at 250 meters. The distance across the 6-degree field of view is shorter at 250 meters.

EXAMPLE:

250 meters by 1,000 meters = .25 or 25 percent of 1,000 meters.

THEREFORE:

.25 by 22 mph = 5.5 mph or 6 mph

6 mph at 250 meters is equivalent to 22 mph at 1,000 meters.

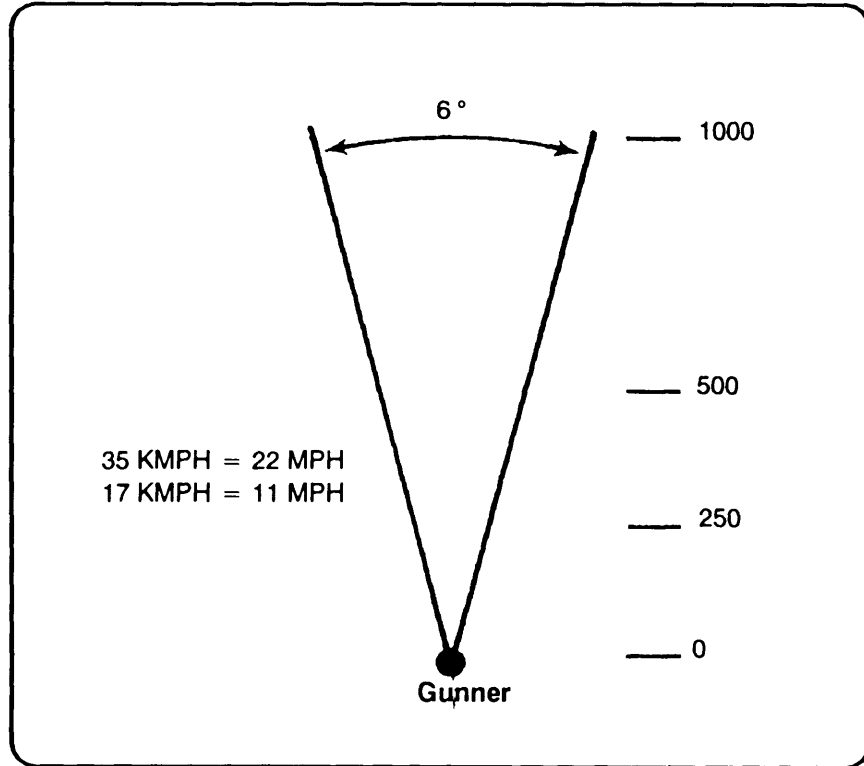

Figure 7-14. Tracker FOV versus simulated speed of target.

7-12. RANGE PROCEDURES

Qualification, verification, or sustainment range firing for gunners and assistant gunners is normally a consolidated battalion or higher function. The officer or NCOIC should use the following procedures when conducting Dragon range firing.

- In all instructional firing, stress precision, steady tracking rate, point training, and firm firing position posture.

- Fire exercises in the order listed on the firing tables; ensure they are controlled by appropriate fire commands.
- Ensure a qualified instructor inspects all Dragon LETs or LESS and trackers before and after each firing day for cleanliness, serviceability, and operation.
- Ensure soldiers apply all safety precautions during all firing exercises.
- Instruct gunners and assistant gunners on duty assignments and range operating procedures before training with the equipment. Divide them into teams and assign each soldier a position.

a. Qualification Training. For qualification, the gunner must fire from both the sitting and standing supported positions. Table 7-1 shows the vehicle speeds and monitor settings that must be used for qualification.

NUMBER OF ROUNDS	MONITOR SETTING	VEHICLE SPEEDS
2	10	0 kmph (0 mph)
2	5	0 kmph (0 mph)
1	3	0 kmph (0 mph)
5	10	10 kmph (6 mph)
5	5	18 kmph(11 mph)
5	3	29 kmph(18 mph)

Table 7-1. Qualification speeds and settings.

b. **Verification Training.** For verification, a gunner must verify quarterly to meet qualification standards.

c. **Sustainment Training.** For monthly sustainment training, (Table 7-2). The commander can select any target speed and monitor settings that must be used for gunner proficiency.

d. **Officer/NCO in Charge.** The officer or NCOIC –

- Organizes the range.
- Assigns, coordinates, and supervises the firing lines.

Ž Issues fire commands and general instructions to the firing line.

- Enforces safety precautions as prescribed in AR 385-62, local SOPs, and applicable range regulations.

e. **Coach and Monitoring Set Operation.** During instructional firing, a coach or monitoring set operator is at each LET or LES to instruct and assist the gunner. The coach or monitoring set operator —

- Requires teams to observe safety precautions.
- Supervises the action at the LET or LES and makes sure that commands are executed.

- Repeats orders and instructions to ensure understanding and timely execution.

- Reports the occurrence of any misfire, malfunction, or discrepancy to the officer or NCO conducting the firing

Ž Critiques the tracking runs.

f. **Training Team.**

Ž LET or LES gunner.

- Loader.
- Monitoring set operator (assistant instructor).
- Scorekeeper (optional).
- Safety monitor (optional).

METERS	18 KMPH (11 MPH)		35 KMPH (22 MPH)	
	KMPH	MPH	KMPH	MPH
1,000	5	3	10	6
900	5	3	10	6
800	5	3	11	7
700	6	4	13	8
600	8	5	14	9
500	10	6	18	11
400	11	7	23	14

Table 7-2. Sustainment speeds.

NOTE: Rotate these duty assignments among the students.

- One target vehicle operator (does not participate in training).

g. Safety Precautions.

(1) *General personnel safety.* Implementing the following precautions ensures safety for all personnel.

- Observe the LET or LES backblast area.
- Ž Wear properly fitted earplugs.
- Reset the dummy weight before loading or reloading the LET.
- Ž Before reloading the LES, ensure there is no glowing residue from the end caps in the launcher.

WARNING: Do not look into the infrared source since eye damage may result.

- Observe the infrared transmitter source safety.
- (2) *Equipment safety.* Avoid rough or careless handling of training equipment.

h. Duty Assignments and Tasks of Training Team Personnel.

(1) *LET Or LES gunner tasks.* Observes the following safety precautions:

- Does not point either end of the LET or LES at personnel.

- Fires only when cleared by the loader.
- Does not look at the sun or at searchlights when sighting through the tracker.
- Considers all misfires to be hangfires, and proceeds accordingly.
- Does not leave a loaded LET or LES unattended.
- Prepares the LET or LES for operation.
- Fires the LET or LES.
- Reviews each tracking run with the monitoring set operator.

(2) *Loader tasks.* Observes the following safety precautions:

- Ž Considers all misfires to be hangfires, and proceeds accordingly.
- Assists in performing misfire procedures.
- Ž Ensures that the hands are clear of the launcher before giving permission to fire.
- Loads or reloads the LET or LES.
- Ž Informs the gunner when to fire.

(3) *Monitoring set operator tasks.* The monitoring set operator performs the following functions:

- Ž Prepares the monitoring set for operation.
- Boresights the monitoring set before training.
- Monitors the set during each tracking run.

- Reviews each tracking run with the gunner.

(4) *Target vehicle operator tasks.* Observes the following safety precautions:

- Before moving the vehicle, ensures that the infrared transmitter set is properly installed on the vehicle.
- Complies with all safety precaution warning signs.
- Ž Before operating the infrared transmitter set, ensures that all cables are connected and secure.
- Ž Removes the infrared source cover.
- Prepares the infrared transmitter for operation.
- Drives the target vehicle.

(5) *Scorekeeper tasks.* The scorekeeper performs the following tasks:

- Ž Prepares the scorecard.
- Informs the instructor of the gunner's progress.

(6) *Safety monitor tasks.* The safety monitor performs the following tasks:

- Ensures all participating team members are using earplugs during the firing exercises.
- Ž Clears personnel from behind the backblast area of the LET or LES during the firing exercises.
- Reports all safety violations to the instructor for corrective action.

7-13. PSTOPERATIONAL PROCEDURES

The instructor ensures the following actions are performed:

LET:

Ž Shuts down the infrared transmitter, replaces the infrared lamp cover, and returns the vehicle to the instruction area.

- Turns off the monitoring set, disconnects and replaces cables in the cable storage area, and replaces the monitoring set covers.

- Dismounts trackers, replaces electrical covers, replaces lens

covers, and places trackers in their carrying cases.

- Replaces rear end caps (shock absorbers) of the LET, forward shock absorbers, and covers.
- Removes batteries from the LET.
- Ensures all M64 grenade launching cartridges are removed.

LES:

- Turns off the power.
- Removes the MAPP gas and oxygen. Shuts down the infrared

transmitter, replaces the infrared lamp cover, and returns the vehicle to the instruction area.

- Turns off the monitoring set, disconnects and replaces cables in the cable storage area, and replaces the monitoring set covers.

Ž Dismounts trackers, replaces electrical covers, replaces lens covers, and places trackers in their carrying cases.

GUNNER QUALIFICATION AND SUSTAINMENT TRAINING PROGRAMS

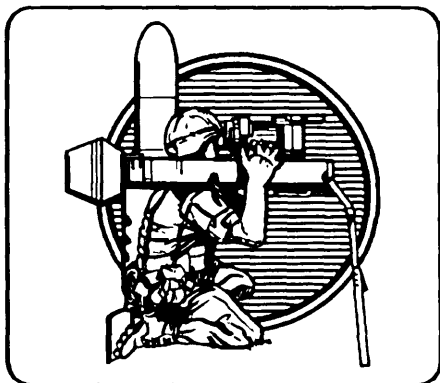

This chapter provides units the guidelines for conducting training to qualify soldiers as Dragon gunners or assistant gunners. A recommended sustainment program is discussed that units should conduct for their qualified Dragon gunners. Training should progress into collective training for applicable MTPs and drill books.

Section I. GUNNER QUALIFICATION PROGRAM

8-1. QUALIFICATION REQUIREMENTS

Units can award the ASI of C2 to soldiers who successfully complete the qualification program IAW AR 600-200, paragraph 2-34a. Commanders verify each soldier has completed the requirements of this section and the following requirements:

- Pass performance test (Appendix B).
- Qualified with the LET (Chapters 7 and 8 and Appendix c).

NOTE: Units must provide a qualified instructor IAW

Chapters 6 and 7. They must allow enough training time for equipment orientation and limit LET firing exercises.

8-2. PROGRAM EXECUTION

This program is designed to be taught in 10 days. Many units may not be able to dedicate the needed

personnel and equipment assets for consecutive training. If so, the

schedule of events should be modified.

a. Negative results are achieved when the training schedule is shortened. Previous instruction review time must be planned at the start of each block. If the training is for a longer period, units consider the following to lengthen or shorten their gunner qualification program:

(1) Maintain quality of instruction. Each instructional period may need to begin with a review.

(2) Teach the tasks in a logical sequence.

(3) Maintain instructor continuity.

(4) Monitor soldier attendance.

b. To assist those units not able to dedicate the necessary personnel and equipment assets for 10 consecutive training days, the periods below are optional and can be deleted. However, should soldiers find difficulty in qualifying

with the LET during Dragon qualification firing, instructional firing must be reinstated.

(1) *Period 4:* Instructional firing.

(2) *Period 8:* Field firing.

(3) *Period 9:* Performance test review or practice.

(4) *Period 15:* Day and night advanced field tracking.

8-3. SKILL AND KNOWLEDGE REQUIREMENTS

Knowledge requirements contain the information that must be taught to the gunner during training. Skill requirements contain those skills that must be developed during training. Prerequisite abilities, skills, and information are assumed essential to mastery of the task. Training objectives are designed to train the gunner, using training devices to master the necessary skills and knowledge. A summary of the critical skill and knowledge requirements and training objectives for each task follows:

a. Task: Maintain a Medium Antitank Weapon.

(1) *Skills and knowledge:*

(a) No special skills are involved in any of the maintenance procedures.

(b) The gunner must conduct PMCS IAW TM 9-1425-484-10. The components that must be checked on the tactical system are visible to the gunner and reduce the difficulty of his task.

(c) Maintenance checks are restricted to cleanliness, physical damage to parts, proper functioning of controls, trigger mechanism,

coolant cartridge, battery gages, and the illuminated reticle on the night tracker. There is no sequence to these tasks until the actual operation of the night tracker.

(d) Maintenance actions are restricted to cleaning procedures and reporting damage to the gunner's supervisor. Special cleaning equipment for the tracker is supplied.

(2) *Training objective:* Perform a Before-Operation Check of the Medium Antitank Weapon System.

(a) Conditions: Given Dragon trackers, a simulated round of ammunition (FHT), cleaning materials, and TM 9-1425-484-10.

(b) Standards: Complete the before-operation checks of the Dragon trackers and simulated round of ammunition (FHT) IAW TM 9-1425-484-10. Correct or report any damage to the supervisor.

b. Task: Prepare a Medium Antitank Weapon for Firing.

(1) *Skills and knowledge:*

(a) To prepare the Dragon for firing involves about 10 steps. Completion of 1 step is the cue for the next step.

(b) The critical skill is to perform all steps quickly and efficiently. Also, the gunner ensures that the backblast area is clear, and he follows all other safety procedures for handling of the round.

(2) *Training objective:* Prepare the Round for Firing.

(a) Conditions: Given a Dragon tracker in the carrying bag or rucksack and a simulated round of ammunition (FHT) in the carrying configuration.

(b) Standards: Mate the tracker to the FHT IAW Chapter 7.

c. Task: Engage Targets With a Medium Antitank Weapon.

(1) *Skills and knowledge:*

(a) An understanding of how the Dragon functions and its firing capabilities and limitations are essential to this task. The four aspects of this task (firing posture, surveillance, target acquisition, and firing and tracking the target) have unique knowledge and skill

requirements. In combination, they present major challenges to the gunner and instructor.

(b) The position of the gunner's body and the relationship between the system and the gunner are critical to the engagement task. For each firing position (sitting, standing supported, kneeling), the gunner must assume the correct firing position as outlined in Chapter 7. The position of the gunner's legs differs for each position, but the goal is to obtain a stable position.

(c) The gunner must also know how to conduct surveillance of an area with both the day or night tracker to detect targets.

(d) Acquisition of the target requires knowledge and decision-making skills to determine whether a target should be engaged. For example, the gunner must answer such questions as:

- Is it friendly or Threat?
- Is it within range? If so, is it engageable?
- Will it move out of range or become nonengageable before a missile could impact?

(e) The gunner must know how to use the stadia lines to determine if the target is within range of the Dragon and whether it is otherwise engageable. Target detection, recognition, and identification skills are acquired for both optical and thermal images. The number of targets that a gunner must know varies with the threat that he is expected to fight. Since the critical cues for recognizing and identifying targets with optical and thermal images differ, the gunner must master two sets of cues. He must also

understand the nature of thermal images and how these images change as the temperatures of the target and the surrounding environment change.

(f) Five procedures or steps are required to fire and track the Dragon: ensure backblast area is clear, place cross hairs on center of mass, push in on safety plunger, pull down on the trigger lever, and maintain cross hairs on the center of mass as the missile goes downrange. The critical aspects of this task are the other requirements placed on the gunner before launch, during launch, and after launch.

- Before launch: The gunner maintains a firm interface between the eye and eye guard, removes slack from the biped, pulls down and rearward, and holds his breath. If the target is moving, the gunner leans in the direction in which the target is moving, so he can rotate to accurately track the target and engage from a stable position. For example, if the target is moving from left to right, the gunner leans to the right.
- During launch: The gunner allows for a 0.6-second delay in the launch of the missile after pressing the trigger. He avoids flinching as the missile leaves the tube and debris starts falling. The launch produces heat and a noise level corresponding to 178 decibels.

• After launch: The gunner maintains the initial aiming position even though the target is obscured for the initial two to three seconds of missile flight. During the target tracking process, the gunner should not

be distracted by the infrared source of the missile as it goes downrange. He holds his breath for the entire flight, maintains the eye firmly in the eye guard (should not blink), and lessens body movement. The gunner's body movement is directly transferred to the missile. The gunner can easily ground the missile because of the movement or can consume all thrusters to adjust the course of the missile, thereby having it fall short of the target.

(2) *Training objective:* Four training objectives are associated with training this task.

(a) Training objective 1: Demonstrate Firing Position.

- Conditions: Given FHT and a tracker prepared for firing.
- Standards: Assume a Dragon sitting position or standing supported position. Prepare to engage a target IAW Chapter 3.

NOTE: The gunner must acquire a proper sight picture.

(b) Training objective 2: Determine if a Target is Engageable.

- Conditions: Given a Dragon tracker mated to an FHT and three or more vehicles in and out of range in a field location.
- Standards: Determine if the three vehicles downrange are within range and if they can be engaged.

NOTE: Do not try to train this task using scaled targets and ranges.

(c) Training objective 3: Qualify With the Launch Effects Trainer.

Ž Conditions: Acting as the gunner, in the sitting and standing supported firing positions; using the LET and tracker (day or night), monitoring set against an M89 target set, and vehicles. See fire qualification tables (Table 7-1 and Appendix C).

- Standards: Each gunner must qualify as follows:
 - Scoring 16 hits out of 20 shots in the sitting position.
 - Scoring 16 hits out of 20 shots in the standing supported position.

(d) Training objective 4: Identify Armored Vehicles (Visually With Daysight).

Ž Conditions: In a garrison or field environment in which armored vehicles are visible in a tactical or a simulated tactical setting. Given a Dragon tracker mated to an FHT prepared for firing.

Ž Standards: Recognize 10 out of 10 vehicles as friendly or Threat IAW STP 21-1 -SMCT, Task Number, 878-924)-1002.

d. Task: Construct a Fighting Position for a Medium Antitank Weapon.

(1) *Skills and knowledge:* This task is based on the principles of constructing each fighting position with a few variations required because of the characteristics of the Dragon system. A critical factor is that the gunner must remember to prepare the position to reduce the target signature of the Dragon and to lessen danger to himself. Physical strength is required to construct the position.

(2) *Training objective:* Construct a Fighting Position for a Medium Antitank Weapon.

(a) Conditions: As part of an FTX or a larger yearly exercise, each Dragon gunner and team constructs a fighting position where local conditions permit such construction. Where local conditions ban construction, units may require gunners to draw a fighting position quarterly.

(b) Standards: The position is constructed IAW Chapter 3, to provide –

Ž Coverage of the assigned sectors of fire.

Ž **Room** for the gunner when firing and preparing another round.

Ž Cover and protection by natural or man-made parapets from small-arms fire.

- Concealment from observation so that the position cannot be detected 65 meters to the front.

e. Task: Prepare an Antiarmor Range Card.

(1) *Skills and knowledge:* The gunner must know all elements of the range card and understand the reason for each element represented on the card. Also, he must use the Iensatic compass, understand the concept of a 360-degree circle, have the mathematics skills necessary for computing back azimuths, estimate range without a map, and accurately represent terrain on the range card (dead space which is critical for the Dragon weapon system).

(2) *Training objective:* Prepare an antiarmor range card (Chapter 3).

(a) Conditions: Given DA Form 5517-R, pencil or pen, and compass, if applicable.

(b) Standards: Prepare an antiarmor range card (Chapter 3).

NOTE: The instructor provides the informational briefing in Chapter 3 to assist the gunner in preparing the range card.

f. **Task:** Perform Immediate-Action Procedures on a Medium Antitank Weapon.

(1) *Skills and knowledge:* The gunner must know the meaning of the terms malfunction, misfire, and hangfire, and understand the logic underlying immediate-action and decision-making procedures. He must perform these procedures under conditions of high stress where danger to himself and other squad or team members are imminent.

(2) *Training objective:* Perform Immediate-Action Procedures for a Dragon Hangfire or Misfire.

(a) Conditions: Given a Dragon tracker mounted on an FHT, prepared for firing and instruction that a failure to fire has occurred.

(b) Standards: Within one minute, perform immediate-action procedures IAW Chapter 4.

g. Task: Perform Emergency Destruction Procedures for a Medium Antitank Weapon.

(1) *Skills and knowledge:*

(a) Know the priority with which the system components should be destroyed: tracker, then round, unless the unit SOP indicates otherwise. If possible, fire the missile at the enemy before destroying the tracker.

(b) Know the possible methods of destroying the Dragon trackers.

- Use a double-primed explosive charge of at least 1/2 pound.
- Use small-arms fire from rifles and grenades, and aim for critical parts such as the optics, trigger assembly, and electronics package.
- Use mechanical means of destruction such as smashing the trackers or driving over them.
- Burn the debris after the most damage has been done by other means.

WARNING: Do not use small-arms fire or mechanical means (such as smashing it) to destroy the round.

(c) Know the possible methods of destroying the Dragon round.

Ž Fire it at the enemy.

- Use 1/2 pound of explosive charge close to the warhead.

(2) *Training objective:* Explain Emergency Destruction Procedures on a Dragon.

(a) *Conditions:* Given a simulated situation in which capture is imminent, and an order to destroy the tracker and rounds of ammunition.

(b) *Standards:* Give the priority of destruction for the Dragon components. Explain the methods of destruction for the weapon system components and ammunition.

h. Task Carry a Medium Antitank Weapon.

(1) *Skills and knowledge:* The gunner must know the different ways of carrying the system, including mated and unassembled configurations and his unit's SOP. He must also know when each carrying configuration is appropriate. The gunner must know safety procedures for carrying the round; that is, to keep the missile pointed downrange in training situations and toward the Threat in combat. He must have the physical strength and stamina to carry the system and have quickly developed skills to maneuver with the system. He must also learn which carrying positions are best for him.

(2) *Training objective:* Carry the medium antitank weapon.

i. Task Restore a Medium Antitank Weapon to Carrying Configuration.

(1) *Skills and knowledge:* The steps in this task are the reverse process of preparing the round for firing. No other information or skills is required.

(2) *Training objective:* None.

j. Task Mount and Dismount for Mechanized units only.

(1) *Skills and knowledge for the Dragon gunner:* Some Dragon gunner requirements are unique to the mechanized infantry. These units have two added pieces of Dragon equipment: the M175 mount and the VPC.

(2) *Training objective.* The M175 guided missile launcher mount provides a stable platform for firing the Dragon missile from the M113 (APC) and the M3 or M122 machine gun tripod. The VPC is installed in an APC to provide power for the Dragon night tracker in place of the externally mounted battery.

- Install and remove the M175 mount.
- Attach both the day and the night tracker.
- Connect the AN/TAS-5 to the VPC.
- Operate the VPC.
- Reload from the M175 mount.
- Install the M175 mount on the M3 and M122 machine gun tripods.

The gunner must also know the correct firing position from within the M113, how to use the M175 mount when firing, additional safety precautions when firing from an M113, and the correct firing positions from the M3 and M122 tripods.

8-4. SUGGESTED SEQUENCE OF TIME AND EVENTS

The following is a suggested sequence of training periods.

a. **First Period.** Orientation on Dragon weapon system—four hours.

(1) *Lesson outline.*

(a) Introduce and explain the Dragon weapon system components and the function of each.

- Tracker.
- Round.
- Preparation of the round for firing

(b) Introduce and explain the Dragon training equipment and the function of each.

Ž Monitor set.

- LET.

Ž Target set, M89.

- FHT.
- LES.

(c) Demonstrate and explain Dragon firing positions.

Ž Sitting.

- Standing supported.
- Kneeling.
- Prone.

(d) Conduct practical exercise.

NOTE: Instructors must refer to Chapter 7 and Appendix C for the correct procedures each gunner should practice.

(2) *Administrative requirements.*

(a) References: Chapters 4,6, and 7; Appendix C; TM 9-6920-484-12; NAVTRADEV P-6054; and TM 9-5855-254-14-HR.

(b) Facilities: A suitable outdoor site to conduct the practical exercise.

(c) Training aids and equipment: For every four soldiers, one each of the following: FHT, LET or LES, monitoring set, and tracker.

b. **Second Period.** Instructional firing – four hours.

(1) *Lesson outline.*

(a) Establish firing line.

(b) Conduct instructional firing (Table 7-1).

(2) *Administrative requirements.*

(a) References: Chapter 3, 6, 7; Appendix C; TM 9-6920-484-12; TM 9-5855-254-14-HR; and CTA 50-970.

(b) Facilities: Tracking range.

(c) Training aids and equipment: One M89 target set with target vehicle. For every four soldiers, one each of the following monitoring set, LET, and tracker (day or night).

(d) Ammunition: 40 grenade cartridges, M64, for each soldier.

NOTE: During all firing, soldiers should practice the correct performance of tasks to prepare for the performance test.

c. **Third Period.** Tank identification and target engage ability -four hours.

(1) *Lesson outline.*

(a) Identify armored vehicles.

(b) Determine if a target is engageable.

(c) Conduct practical exercises on tank identification and target engageability

(2) *Administrative requirements.*

(a) References: Chapter 3, TM 9-1425-484-10, TM 9-6920-484-12, TM 9-5855-254-14-HR, CTA 50-970, and STP 21-24-SMCT.

(b) Facilities: A tracking range or other site suitable to conduct practical exercise.

(c) Training aids and equipment: LETs or FHTs, trackers (day or night), 1:35-scale vehicles, GTA 17-2-13, and Dragon sight reticle.

(d) Ammunition: None

d. **Fourth Period.** Instructional firing– four hours.

(1) *Lesson outline.*

(a) Establish firing line.

(b) Conduct instructional firing IAW Chapter 7.

(2) *Administrative requirements.*

(a) References: Same as Second Period.

(b) Facilities: Tracking range.

(c) Training aids and equipment: See Second Period.

(d) Ammunition: 40 grenade cartridges, M64, for each soldier.

e. **Fifth Period.** Perform misfire procedures on a medium antitank weapon and emergency decontamination and destruction procedures – two hours.

(1) *Lesson outline.*

(a) Conduct a preoperational inspection of the components.

- Tracker (day and night).

- Round.

(b) Demonstrate immediate-action procedures.

- Hangfire procedure,

- Misfire procedure.

(c) Demonstrate emergency decontamination procedures on a Dragon.

(d) Demonstrate emergency destruction procedures on a Dragon.

(e) Conduct practical exercise.

(2) *Administrative requirements.*

(a) References: Chapter 4, Appendix D, TM 9-1425-484-10, TM 9-6920-484-12, and TM 9-5855-254-14-HR.

(b) Facilities: A site suitable to conduct practical exercise.

(c) Training aids and equipment: FHT, tracker, Dragon cleaning kit, decontaminating kit, canteen of water, and soap and rags for every four soldiers.

(d) Ammunition: None.

f. Sixth Period. (Mandatory) Field firing – six hours.

(1) *Lesson outline.*

(a) Establish a firing line.

(b) Conduct instructional firing (Chapter 7 and Appendix C).

(2) *Administrative requirements.*

(a) References: Same as Second Period.

(b) Facilities: Training range.

(c) Training aids and equipment: M89 target set with target vehicle and one each of the following for every four soldiers: monitoring set, LET or LES, and tracker.

(d) Ammunition:

Ž LET firing 35 grenade cartridges, M64, for each soldier.

- Ten LES end caps for each soldier.

- NOTE: Ensure that there is enough oxygen and MAPP gas for all soldiers to fire.

g. Seventh Period. Construct range cards and fighting positions — four hours.

(1) *Lesson Outline.*

(a) Prepare an antiarmor range card.

(b) Prepare a Dragon fighting position.

(2) *Administrative requirements.*

(a) References: Chapter 3, TM 9-1425-484-10, TM 9-6920-484-12, and TM 9-5855-254-14-HR.

(b) Facilities: An area suitable to conduct a practical exercise.

(c) Training aids and equipment: Enough trackers, FHTs, or LETs or LESs to do the exercises and charts showing the Dragon range card and Dragon fighting position.

(d) Ammunition: None.

h. **Eighth Period.** Field firing – four hours.

(1) *Lesson outline.*

(a) Establish firing line.

(b) Conduct instructional firing (Chapter 7) with mixed positions.

(2) *Administrative requirements.*

(a) References: This manual, TM 9-1425-484-10, TM 9-6920-484-12, TM 9-5855 -254-14-HR, and CTA 50-970.

(b) Facilities: Tracking range.

(c) Training aids and equipment: See Second Period.

(d) Ammunition: 40 grenade cartridges, M64, for each soldier.

i. **Ninth Period.** Performance test review or practice — four hours.

(1) *Lesson outline.*

(a) Introduce test procedures.

(b) Review test standards.

(c) Conduct practical exercise, and test on training objectives and or tasks.

(2) *Administrative requirements.*

(a) References: This manual, TM 9-1425-484-10, TM 9-6920-484-12, TM 9-5855-254-14-HR, and CTA 50-970.

(b) Facilities: A site suitable to conduct the performance test.

(c) Training aids and equipment: Range cards, 1:35-scale tanks, and a chart of Dragon fighting positions; one each of the following for every four soldiers: tracker (day or night), LET or LES, and monitoring set.

(d) Ammunition: None.

j. **Tenth Period.** Dragon qualification firing — four hours.

(1) *Lesson outline.*

(a) Establish the firing line.

(b) Conduct qualification firing (Table 7-1 and Appendix C).

(2) *Administrative requirements.*

(a) References: This manual, TM 9-1425-484-10, TM 9-6920-484-12, TM 9-5855-254-14-HR, and CTA 50-970.

(b) Facilities: Tracking range.

(c) Training aids and equipment: See Second Period.

(d) Ammunition: 40 grenade cartridges, M64, for each soldier.

k. **Eleventh Period.** Performance testing – four hours.

(1) *Lesson outline.*

(a) Test soldiers on the following training objectives:

- Before-operation PMCS.
- Preparation of the round for firing.
- Firing positions.

- Immediate action.
 - Identification of armored vehicles.
 - Target engageability.
 - Ž Dragon fighting positions.
 - Ž Dragon range cards.
 - Decontamination procedures.
 - Destruction procedures.
- (b) Conduct soldier critique concurrently.
- (2) *Administrative requirements.*
- (a) References: TM 9-1425-484-10, TM 9-6920-484-12, TM 9-5855-254-14-HR, and CTA 50-970.
- (b) Facilities: Tracking range.
- (c) Training aids and equipment. See Second Period.
- (d) Ammunition: None.
- (e) See Appendix B for evaluation guides.

l. Twelfth Period. Dragon qualification firing – four hours.

- (1) *Lesson outline.*
- (a) Establish the firing line.
- (b) Conduct qualification firing (Chapter 7 and Appendix C) standing supported position.
- (2) *Administrative requirements.*
- (a) References: This manual, TM 9-1425-484-10, TM 9-6920-484-12, TM 9-5855 -254-14-HR, and CTA 50-970.
- (b) Facilities: Tracking range.
- (c) Training aids and equipment: See Second Period.
- (d) Ammunition: 40 grenade cartridges, M64, for each soldier.

m. Thirteenth Period. Orientation on Dragon maintenance—four hours.

- (1) *Lesson outline.* Introduce and explain maintenance on the Dragon components and training equipment.
- Ž Tracker.
 - Round.
 - Monitoring set.
 - Ž LET.
 - Ž Target set, M89.
 - Ž FHT.
 - Ž LES.
 - Night tracker (AN/TAS-5).
 - Mount, M175.

(2) *Administrative requirements.*

- (a) References: TM 9-1425-48-4-10, TM 9-6920-484-12, NAVTRADEV P-6054, and TM 9-5855-254-14-HR.
- (b) Facilities: A site suitable to conduct a class or tracking range.
- (c) Training aids and equipment: Day tracker, round, M89 target set, LET or LES, monitoring set, and FHT; one each of the following for every four soldiers: M175 mount and night tracker (AN/TAS-5).
- (d) Ammunition: None.

n. Fourteenth Period. Retest performance test and or refire qualification – four hours.

- (1) *Lesson outline.*
- (a) Introduce test procedures.
- (b) Review test standards.
- (c) Conduct test.
- (d) Perform soldier critiques.
- (e) Establish firing line.

(f) Conduct Dragon qualification refire.

(2) *Administrative requirements.*

- (a) References: TM 9-1425-484-10, TM 9-6920-484-12, TM 9-5855-254-14-FIR, and CTA 50-970.
- (b) Facilities: A site suitable to conduct the performance test or a tracking range.
- (c) Training aids and equipment: See Second Period.
- (d) Ammunition: 20 grenade cartridges, M64, for each soldier per table being retested.
- o. Fifteenth Period. Day and night advanced field tracking—four hours.

(1) *Lesson outline.*

- (a) Explain the purpose of the exercise.
- Ž Place the gunner in simulated battlefield conditions.
 - Ž Build the gunner’s confidence in the weapons system.
 - Ž Allow the gunner to practice sighting, firing, and tracking to improve his concentration.
 - Require the gunner to make engageability decisions.
 - Ž Present the gunner with multiple target engagements.
- (b) Conduct daylight advanced tracking exercise (two hours).
- Ž Target vehicles should be uncooperative; for example, constantly changing speed, direction, angle of attack, and exposure time. Target vehicles should operate in pairs and teams as well as alone. They should move out of range and

back into range so that the gunner can acquire experience to determine if a target can be engaged. Target vehicles can reduce exposure time by halting at covered areas, traveling covered routes between firing positions, and firing from hull-down positions.

- Both the gunner's position and target area should be subjected to intermittent obscuration by use of smoke grenades or smoke pots. The gunner should be subjected to battlefield noises from artillery and hand grenade

simulators. Target vehicles should be provided with smoke capability and weapons simulators, if available.

(2) *Administrative requirements.*

- (a) References: This manual.
- (b) Facilities: Afield tracking area at least 500 meters wide and greater than 1,000 meters deep. It should contain hills and valleys, dead space, areas offering concealment, and prepared fighting positions.
- (c) Training aids and equipment: Tactical vehicles with MILES equipment to act as targets

(preferably M-1 M60-series tank or M2/M113 APC), AN/PRC-77 radios, and bullhorn; and one MILES Dragon for every four soldiers.

(d) Ammunition.

- Enough smoke pots, smoke grenades, and artillery simulators to simulate battlefield conditions.
- Fifteen ATWESS cartridges for each soldier (to simulate noise effect).

TOTAL: 60 hours.

Section II. SUSTAINMENT TRAINING PROGRAM

Unit commanders receive qualified gunners either from the United States Army Infantry School or from a unit-conducted training program

(Section I). Completing either of these basic training programs does not complete gunner training. Each gunner must have sustainment

training because gunner tracking skills quickly degrade.

8-5. GUNNER SUSTAINMENT TRAINING

Gunner sustainment is conducted monthly, quarterly, or annually.

a. Monthly sustainment training consists of the gunner firing one 20-shot table and as many hands-on tasks as time allows. The next month, the gunner fires one 20-shot table and the hands-on tasks not performed the previous month. Monthly sustainment only occurs eight times a year. The other four months are used for gunner qualification/verification.

b. Each quarter, the gunner must have time allotted to fire two firing tables and complete the hands-on tasks. If the gunner should fail to qualify/verify in the allotted time, more time must be allocated for makeup qualification or hands-on testing. Gunners are allowed three tries to qualify/verify.

c. The commander should schedule an annual live-fire exercise after the gunners complete one of the quarterly qualification/verification tests. This live-fire exercise is the real

test of gunner training. While some units may receive more missile(s) than others, commanders must ensure that the missile(s) are fired by qualified Dragon gunners.

d. A soldier should not be allowed to fire a live missile if he has not qualified with the LET and or fired the LES within the last month. The matrix in Table 8-1 identifies the specific tasks and subjects that must be performed by all Dragon gunners and assistant gunners.

SUBJECT	TNG FREQ	TIME	REMARKS
MAINTAIN AN M47 MEDIUM ANTITANK WEAPON	MQ	10 min	Practical Exercise
PREPARE AN M47 MEDIUM ANTITANK WEAPON FOR FIRING	MQ	30 sec	Practical Exercise
ENGAGE TARGETS WITH AN M47 MEDIUM ANTITANK WEAPON	MQ	8 to 16 hrs	Practical Exercise
PERFORM MISFIRE PROCEDURES ON AN M47 MEDIUM ANTITANK WEAPON	MQ	15 min	Practical Exercise
RESTORE AN M47 MEDIUM ANTITANK WEAPON TO CARRYING CONFIGURATION	MQ	5 min	Practical Exercise
PREPARE AN ANTIARMOR RANGE CARD	MQ	15 min	Practical Exercise
RECOGNIZE FRIENDLY AND THREAT ARMORED VEHICLES AND AIRCRAFT	MQ	15 min	Practical Exercise
CONSTRUCT A FIGHTING POSITION FOR AN M47 MEDIUM ANTITANK WEAPON	MQ	NA	Perform in conjunction with ARTEP or FTX
EXPLAIN EMERGENCY DECONTAMINATION PROCEDURES FOR AN M47 MEDIUM ANTITANK WEAPON	MQ	10 min	Oral Presentation
EXPLAIN EMERGENCY DESTRUCTION PROCEDURES FOR AN M47 MEDIUM ANTITANK WEAPON	MQ	10 min	Oral Presentation
FIELD SUSTAINMENT TRAINING	M	4 hrs	Practical Exercise
M - Monthly Q - Quarterly			

Table 8-1. Training tasks for Dragon gunners and assistant gunners.

8-6. COLLECTIVE TRAINING

Training with the Dragon/MILES is an excellent means of keeping a gunner's engagement skills sharp (Table 8-2). MILES is not a gunnery trainer and should not be used in place of the sustainment training.

SEQUENCE	FREQUENCY: TIME/YEAR	HOW
SQUAD, PLATOON, OR COMPANY FYX	4	MILES
BATTALION FTX	2	MILES
PLATOON/COMPANY MOUT EXERCISE	1	MILES
SQUAD, PLATOON LFX	2	MILES/LTIDs
EXTERNALLY EVALUATED BATTALION MTP	1	MILES

Table 8-2. MILES training program.

THERMAL TARGET RECOGNITION, IDENTIFICATION, ENGAGEMENT

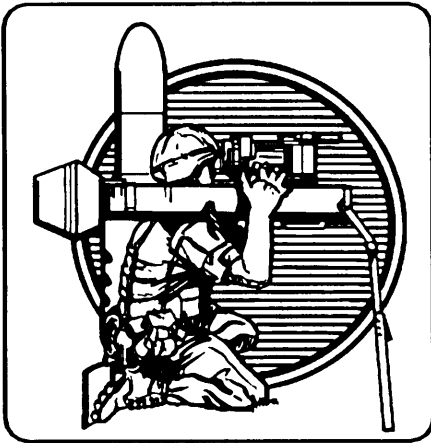

The night tracker allows the Dragon gunner to view targets during limited visibility. This requires gunner training on thermal target recognition, identification, and engagement. The gunner must interpret unusual images with the night tracker. These images, called thermal target signatures or infrared target signatures, are different from the images seen in the day tracker. Targets stand out in these infrared images and can be recognized at long ranges on a clear night and at reduced ranges during limited visibility. However, the recognition task requires trained and experienced gunners. The information in this chapter provides a “training base” until more training techniques can be developed.

A-1. TEMPERATURE AND THERMAL IMAGES

Most objects have a radiated temperature either higher or lower than their background. Even if the radiated temperature differences are less than a degree, they appear in the night tracker display. If there is no difference between the temperature of an object and its background, the object is not seen in the display. If an object has a higher

temperature, it appears bright red in the night tracker. If the object has a lower temperature, it appears black.

a. Usually, targets are easier to identify at night because their radiated temperature is hotter than their background. Some targets, such as tanks and APCs, have internal temperature variations that form visible patterns. These patterns

are the basics of target signature cues.

b. In a night tracker, the shapes of the hottest vehicle parts, such as engines and exhausts, appear bright red. Objects with a medium temperature, such as the warm tracks, appear a dim red. Objects with a cool temperature, such as the cool hull, appear black.

A-2. SOURCES OF INFRARED ENERGY

The sources of infrared energy are solar heat, fuel combustion heat, frictional heat, and reflected radiance.

a. **Solar Heat.** Solar heat comes from the sun and affects the exterior surface of objects.

(1) This heating highlights the outline of the object, which provides recognition cues to the gunner, which are usually similar to the overall appearance of the target. For example, a solar-heated M113 appears box-like with a sloping front; a solar-heated M60 tank appears as a small oval atop a larger oval. These shape cues are recognizable out to medium ranges (800 to 1,200 meters) and detected at long ranges (2,000 meters). Since the sides of vehicles have more defined contours, side views are usually easier to recognize than the front views.

(2) Besides atmospheric variables and surface reflections, the solar heating rate is also affected by the object's ability to absorb sunlight. Dark-colored objects are normally better absorbers of sunlight than the light-colored objects.

b. **Fuel Combustion Heat.** Fuel combustion heat comes from operating engines. The heat is conducted to the surfaces of the surrounding engine compartment. Because engine compartment

temperatures reach up to 200 degrees F, the surfaces of these compartments radiate features that can be detected.

(1) Heated personnel space is also visible. Likewise, engine muffler and exhaust pipe temperatures are high, which also provide the gunner with good cues. The engine, heated compartments, and exhaust features themselves do not appear in the night tracker. This does not decrease their cue value. However, a trained and experienced gunner can determine much about the vehicle from these cues since they are hot and easily detected at long ranges.

(2) A gunner can determine from the engine and exhaust cues whether the vehicle is a front-engine or rear-engine vehicle. If the vehicle is making evasive maneuvers, a gunner can locate the vehicle exhaust, which is an important cue.

c. **Frictional Heat.** Frictional heat is produced by the moving parts of vehicles and heat is less intense than the high temperatures from the engine combustion.

(1) Frictional heat is generated only when the vehicle is in motion. However, these features usually appear a dim red. Frictional heat provides long-range cues to classify the vehicle as wheeled or tracked. At short range to medium range, these

cues can be used to identify the vehicle. However, if the vehicle is moving through high vegetation or causing dust, the visual cues can be lost.

(2) The vehicle's transport systems are the source of most frictional heat cues. Tracked vehicles have frictional heat in the tracks, road wheels, drive sprockets, support rollers, and shock absorbers. The smallest of these features can be identified at longer ranges when they are hot. Wheeled vehicles have frictional heat in the tires, shock absorbers, drive shafts, transmissions, axles, and differentials. The tires, shock absorbers, and differentials can be detected at medium range to long range (if there is no tall vegetation or a great deal of dust).

d. **Reflected Radiance.** Smooth, glossy surfaces, such as windshields and glossy, painted fenders, reflect radiation images from other sources. These reflections can produce odd images. For example, the fenders of a T-62 appear black because of this thermal reflection; a glossy, painted APC could be reflected off the vehicle's flat-side surfaces. An overcast sky can cause warmer thermal reflections. Generally, surface reflections are diffuse in nature and do not usually cause problems.

A-3. EFFECTS OF WEATHER AND OBSCURANTS

Variations in solar heat, fuel combustion heat, frictional heat, and thermal reflection affect infrared

signatures and infrared target recognition cues. Also, some atmospheric conditions degrade the

night tracker, while others can enhance it.

a. **Falling Precipitation.** Infrared energy does not transmit well through falling precipitation (rain, snow, fog). The temperatures of targets and background objects are decreased. The basic signature cues themselves do not change because of atmospheric transmission losses. Falling precipitation restricts night tracker visibility more than precipitation that has fallen.

(1) During rain or snow, background objects and frictionally heated and solar-heated target features lose heat. Frictional heat loss is caused by

water and mud collecting on the tracks, wheels, and other transport system parts. Engine compartment and exhaust temperatures remain high. Landmarks, such as trees, trails, and contour features, are often lost. The loss of heat in background objects reduces scene clutter, such as trees and rocks, and can increase target detection. Target recognition cues are usually reduced because of the loss of heat from certain target features.

(2) Because rain and snow have a cooling effect on the target's

contrast, the night tracker contrast controls must be increased to compensate for the condition, which can produce a "snowy" image.

b. **Fallen Snow.** Fallen snow tends to make all ground temperatures the same. Depth perception by size comparison becomes difficult because of the lack of terrain features with which to reference size.

c. **Dust, Diesel Fog, and Oil Smoke.** Dust particles from the impact of artillery greatly reduce night tracker performance.

A-4. COMPENSATION FOR TARGET APPEARANCE VARIABLES

Although vehicles have distinguishing characteristics or cues by which they can be classified and identified, vehicle appearance can be altered by changes in atmospheric and ground conditions. Therefore, the gunner must know how to use the control settings of the night tracker to help compensate for these variables.

a. **Contrast and Brightness Controls.** The contrast and brightness controls can be set for maximum internal detail of the target. The controls are balanced to give the clearest image of these target recognition cues. The following is general guidance for setting the image brightness and contrast controls. Gunners should be encouraged to experiment with the image controls to understand their effects on the thermal image and thermal signatures.

(1) *Brightness, low; contrast, medium to high:* These settings are for seaming an area in search of targets. Background clutter is suppressed.

Cool objects are not visible. Only the hot objects in the field of view are seen. When a possible target has been found, brightness can be increased and contrast can be lowered gradually to reveal more thermal detail in the suspected target. Low brightness and medium-to-high contrast settings are used in rain, dust, and light fog conditions.

(2) *Brightness, low to medium; contrast, medium:* This is the best overall setting for target detail. With medium contrast, brightness can be varied up and down to bring out features and determine the hottest vehicle parts. When brightness is lowered, the cooler parts, such as tracks, darken before hotter parts. Often, small changes in brightness can reveal much about the vehicle. For example, road wheels can sometimes be seen at long ranges if this technique is used. Experimentation is helpful in learning this target feature extraction technique.

(3) *Brightness, medium; contrast, medium to high:* These settings work well in heavy fog or heavy dust when little can be seen with the Dragon. The settings increase the snowy effect in the image, but they also increase the apparent sensitivity of the sight. The image appears distorted and is hard to interpret. These settings are also good for searching a tree line in wet conditions and are sometimes useful with long-range targets. Beyond 1,200 meters, small target images, such as the front view of a BRDM-2, will have few recognizable features. At long ranges, the higher contrast setting highlights the vehicle's hull and overall silhouette. This does not provide vehicle recognition, but it does help the target stand out from the background and aid in target detection.

b. **Focus Controls.** Most night tracker focus controls are sensitive; that is, a small movement of the control knob results in a large change in focal point. If a gunner has difficulty in focusing, he should

check the adjustment of the image controls.

(1) The eyepiece focus should be adjusted first. Correct reticle adjustment can be obtained by focusing the eyepiece so that the reticle is focused.

(2) The second focus adjustment is the range focus lever. The image

controls should be adjusted at the low-to-medium level before focusing the objective lens. Focusing the objective lens is learned through trial and error. It is made difficult by the fact that infrared heat diffuses on objects and does not usually give clear-cut, straight lines on which to focus. Thus, the gunner must learn to

focus by adjusting the control back and forth to obtain the best image. This is easier to do when the night tracker is aimed at a prominent object. Once the best image is determined, the gunner can experiment by focusing on different objects at different ranges,

A-5. BATTLEFIELD IDENTIFICATION

Battlefield identification using a night tracker is difficult, but the problem is being studied. Little is known about the ranges at which high-confidence identification can be expected. In a target-rich environment on a dry, clear night, high-confidence identification requires a thermal image of such features as road wheels, turret

shapes, gun tube, and exhaust location. Limited experience indicates that the M60 versus T-62 thermal identification can be made between 800 to 1,200 meters in clear weather. In identifying targets, a gunner should ask himself the following questions:

Ž Is the target moving and in what direction?

- Where is the engine?
- Where is the exhaust?
- Ž Is the target in the unit's section? Should it be there?
- Is it in a formation?
- Ž Is it firing at a friendly or enemy units?

A-6. PRIMARY RECOGNITION CUES

The following friendly and enemy vehicle recognition cues help in training gunners.

a. M60A1 Main Battle Tank (Figure A-1).

(1) *Classification:*

(a) Rear-engine vehicle.

(b) Oval-shaped track and road wheel pattern.

(c) Overall hull, turret, and gun pattern may be visible with the maximum setting.

(d) Gun tube visible when recently fired.

(2) *Identification:*

(a) Side view cues:

Ž Rear-engine vehicle with rearward exhaust.

- High-profile track pattern with hot, taut tracks. (Six evenly spaced road wheels and three support rollers can be seen, especially at short ranges.)

Ž Large centrally mounted turret.

Ž Medium-length gun tube can be seen, especially at short ranges. The gun tube is visible at long ranges when recently fired. (The bore evacuator is two-thirds of the way down the length of the barrel.)

Ž High overall profile with a large turret mounted in the center.

- Left and right views are the same.

(b) Front view cues:

Two warm tracks separated by a cool hull. (Lower front hull seems warm, if a personnel heater has been operating.)

Ž Cool front hull denotes a rear-engine vehicle.

- One track seems wider if the vehicle is positioned slightly oblique to the viewer.
- Gun tube is visible when the gun has been recently fired.

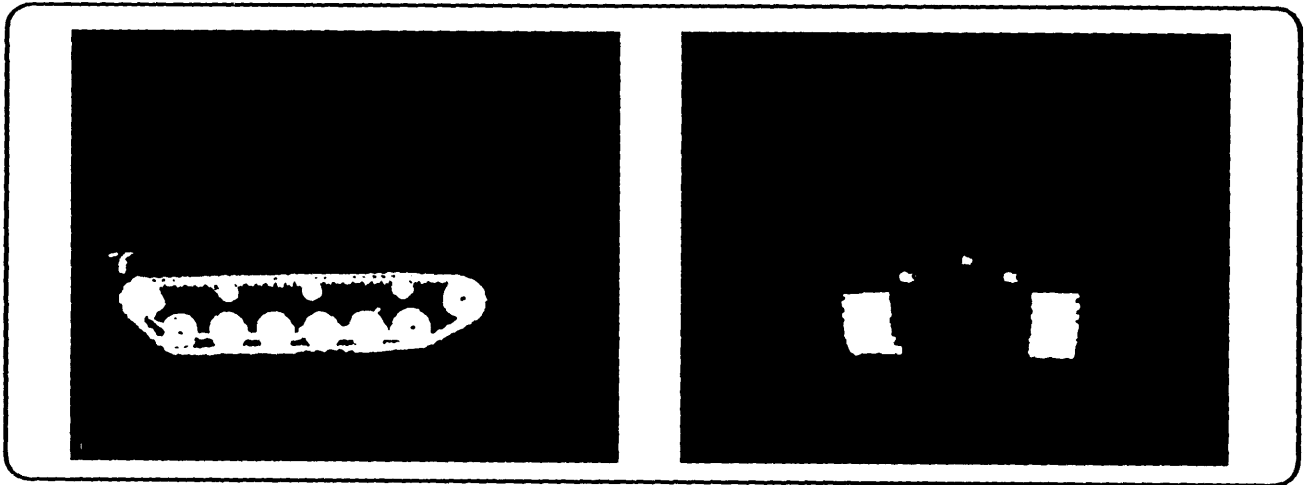

Figure A-1. M60A1 main battle tank.

(3) *Effects of motion:*

- (a) Changing target views often reveal more features.
- (b) Direction of movement denotes engine location.
- (c) Transport system becomes warmer and more visible.
- (d) Bouncing is slower than that of a light vehicle.
- (e) Exhaust plume location and direction are sometimes visible.

NOTE: When compared to the T-62, the side view of the M60A1 track pattern is higher and more uniformly warm. T-62 tracks are cooler toward the front and smaller than those of the M60A1. In the front view, the M60A1 appears hotter and larger than the T-62.

b. **M551 Light Tank** (Figure A-2).

(1) *Classification:*

- (a) Rear-engine vehicle.

- (b) Oval-shaped track and road wheel pattern.
- (c) Overall combined hull, turret, and gun pattern.
- (d) Gun tube is visible when it has been recently fired.

(2) *Identification:*

- (a) Side view cues:
 - Rear-engine vehicle with rear exhaust. (Exhaust plume maybe directed upward or rearward.)

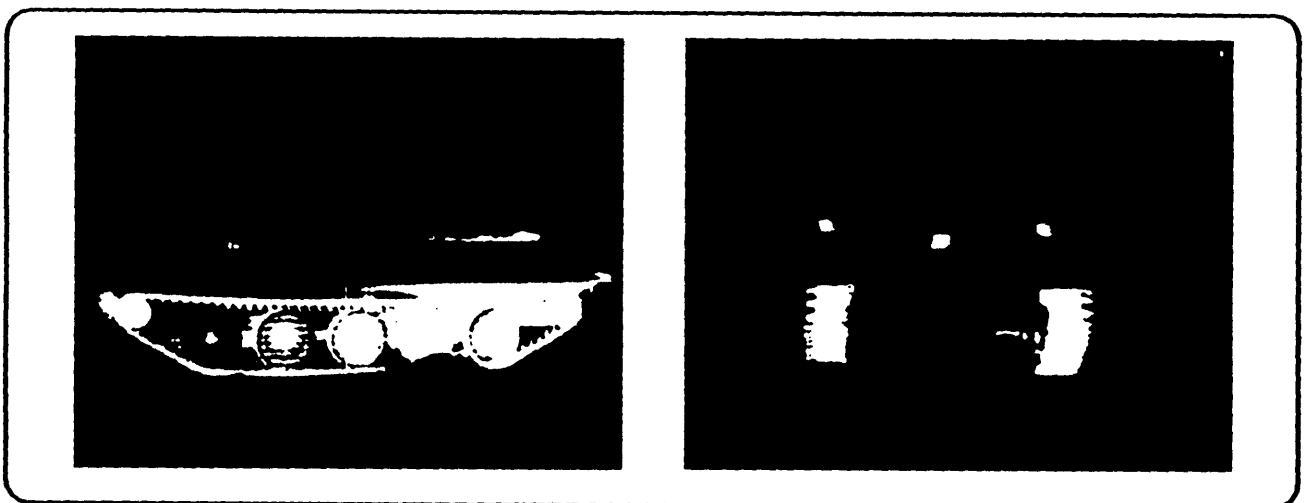

Figure A-2. M551 light tank.

Ž Low-profile and warm, slack tracks. (Five evenly spaced road wheels can be seen at short range.)

- High-side decking and low-slack track profile combine to give the vehicle a wedge-like appearance between 800 to 1,200 meters. (The wedge points toward the vehicle's front.)
- Right and left side signatures are the same.
- Low, overall hull and small turret profiles.

Ž Short gun tube visible when recently fired.

- Small, low, flat-shaped, front turret.

(b) Front view cues:

- Turret is wide and low. Turret sides extend almost over tracks for a unique front view when the profile is visible; this is an important cue.
- Warm tracks with a cool hull separating them give a signature of two red spots.

(3) *Effects of motion:*

- (a) Changing target views often reveal more features.
- (b) Direction of movement denotes engine location.
- (c) Transport system becomes warmer and more visible.
- (d) Bouncing is slower than that of a light vehicle.
- (e) Exhaust plume location and direction are sometimes visible.

NOTE: M551 signatures look much like those of the T-62. Most distinguishing differences are turret width (front view) and wedge-shape side views.

c. M113 Armored Personnel Carrier (Figure A-3).

(1) *Classification*

- (a) Front-engine vehicle.
- (b) Oval-shaped track and road wheel pattern.
- (c) Overall box-shaped hull (may reveal the absence of a turret).

(2) *Identification:*

(a) Side view cues:

- Right-side view shows characteristic hot front corner, even at long range.
- Low track and track skirts with five evenly spaced road wheels. Track skirts give tracks a low-profile appearance in the side view.
- Right side with hot engine spot, and left side with cool box shape.
- Bevelled shape of the front end is visible from the right side. Overall box shape is visible from the left side at maximum settings.

(b) Front view cues:

- Ž Front engine in right corner is the brightest spot on the image.
- Ž Dark surfboard is visible across the front.
- Ž Overall box shape is visible at maximum setting.
- Engine exhausts upward from the right corner of the vehicle.

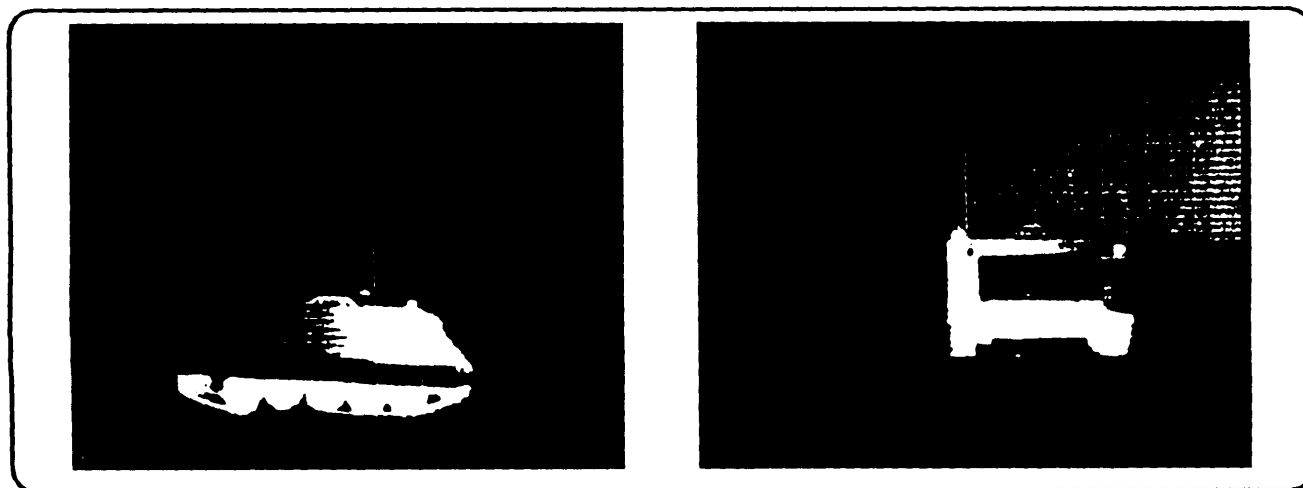

Figure A-3. M113 armored personnel carrier.

Exhaust gas is visible at short range.

(3) *Effects of motion:*

(a) Changing target views often reveal more features.

(b) Direction of movement denotes engine location.

(c) Because of vehicle weight and transport system, bouncing is intermediate because of the slow bouncing of tanks and choppy bouncing of light vehicles such as 1/4-ton and 1 1/4-ton trucks.

(d) Exhaust plume location and upward direction are sometimes visible.

(e) Transport system becomes warmer and more visible.

d. Trucks. (All truck cues are combined) Figure A-4).

(1) *Classification and identification:*

(a) Side view cues:

Ž Front-engine cue is a prominent square from the front and sides. The entire hood and radiator usually appear hot.

Ž Rear wheels are usually warm spots separated from front wheels and can be easily distinguished from a track pattern. Front wheels are often merged with engine hot spot.

- Cab and hood silhouette side view is sometimes distinguishable at maximum settings. Long-bed trucks often appear as other truck shapes from the side, even at long ranges.

- Diagonal shape of the drive shaft is often visible as a bright area joining the engine and rear wheels.

- Exhaust pipes and stacks appear hot along their entire length and compose shapes determined by how they are routed through the vehicle's frame.

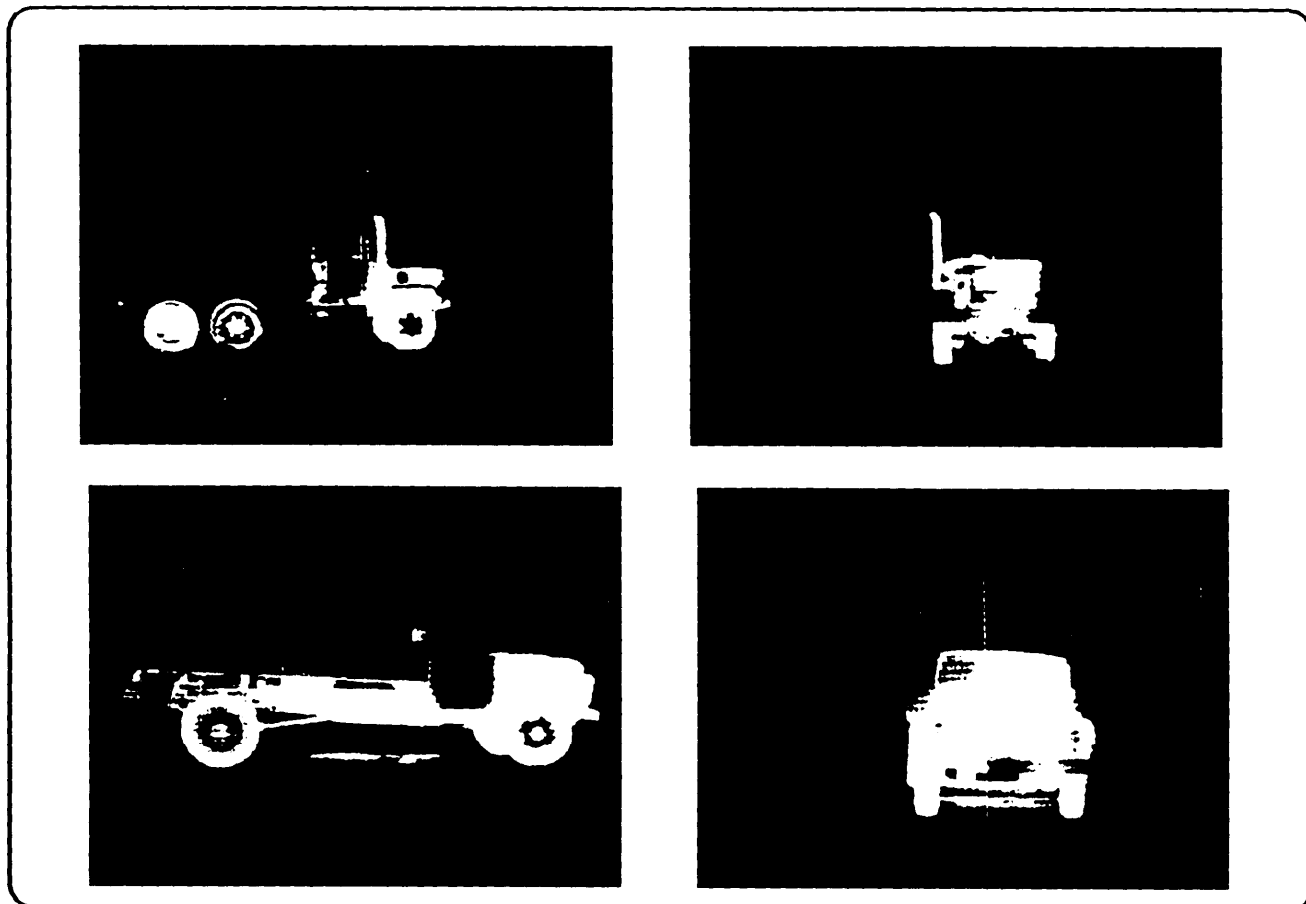

Figure A-4. Trucks.

(b) Front view cues:

- Front views are all similar at medium and long ranges. Signature is a bright red square or rectangle.
- Large, square red spot is produced by the hot engine compartment, hood, radiator, and cab (if personnel heater is in use).

Ž Wheels and front axle area often are merged to produce a continuous red spot beneath the engine. This image can be improved so wheels can be seen if lower settings are used.

Ž External size cues are needed to establish vehicle size. To estimate the size of a cue, relate a nearby tree or other background feature to the red spot. Also, use the sight reticle to gage size. Use low to medium settings to increase the accuracy in sizing.

(2) *Canvas and wood parts:* These parts usually appear cool at night and warm during the day.

e. **T-62 Medium Tank** (Figure A-5).

(1) *Classification:*

- (a) Rear-engine vehicle.
- (b) Oval-shaped track and road wheel pattern.
- (c) Overall combined hull, turret, and gun pattern may be visible with maximum setting.
- (d) Gun tube is visible when it has been recently fired.

(2) *Identification:*

(a) Side view cues:

- Ž Rear-engine vehicle with left side exhaust.
- Ž Low-profile slack tracks (five road wheels with unique spacing visible at short ranges).
- Ž Left side is hotter than right side.
- From left side, the rear half of the vehicle has a much larger heated area than the front half.
- Ž Low overall profile with cool hull.

- Long gun tube (is visible when it has been recently fired).

- Small, centrally mounted turret.

Front view cues:

Ž Cool, low, overall profile with warm tracks separated by a cool hull.

- Cool fenders above tracks may appear black.

Ž Small, dome-shaped turret.

- Long gun tube is visible when it has been recently fired. It appears as a red spot when aimed toward the unit. When fired, it is visible only at short ranges.

(3) *Effects of motion:*

(a) Changing target views often reveal more features.

(b) Direction of movement denotes engine location.

(c) Transport system becomes warmer and more visible.

(d) Bouncing is slower than that of a light vehicle.

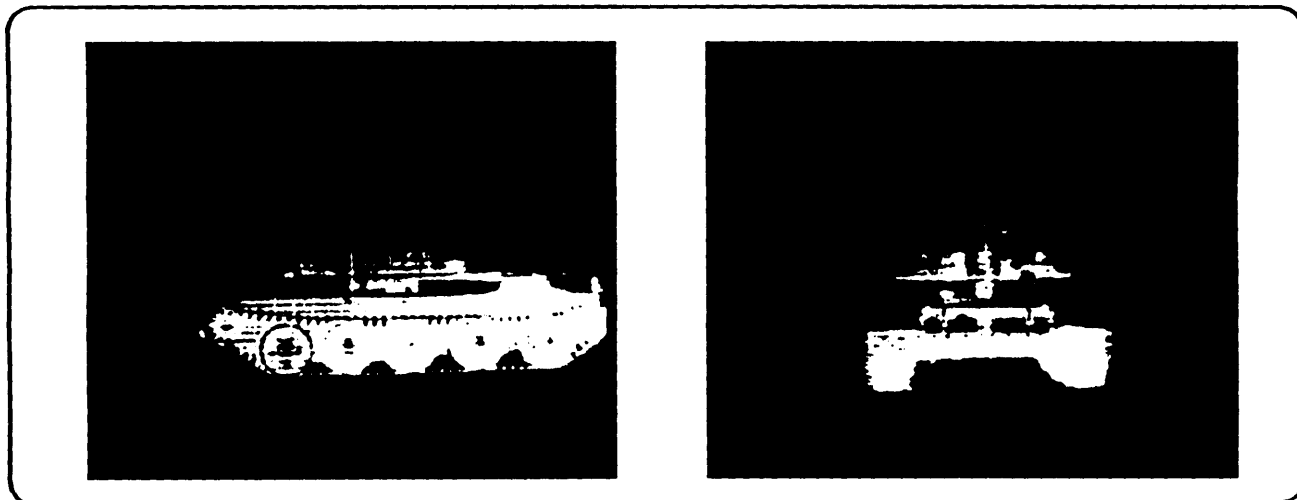

Figure A-5. T-62 medium tank.

(e) Exhaust plume location and direction are sometimes visible.

f. BMP Infantry Combat Vehicle (Figure A-6).

(1) *Classification:*

(a) Front-right corner engine location from right side and front views.

(b) Taut track pattern is visible. At close range, wheels and support rollers are visible.

(c) Overall low profile is visible at higher settings.

(d) Gun tube is visible when it has been recently fired.

(2) *Identification:*

(a) Side view cues:

- Engine exhaust port is the hottest side feature (right side).
- Engine compartment provides a larger red spot in the forward half of the vehicle.

- Track pattern is visible at long ranges.

Ž Forward end of vehicle slopes up from the track to the front fender.

Ž Cool track fenders block the view of the upper track.

- At long ranges, the heat pattern of tracks and the engine area forms a boat-like pattern (right side).

Ž Right side is hotter and usually more recognizable.

Ž Vehicle has long low shape that is visible at high settings.

(b) Front view cues:

- Engine in right front gives square-shaped red spot.

Ž Cool front deck panel gives a black line across the engine red spot.

Ž Exhaust on right side vents upward from the side of vehicle. (Plume is sometimes visible.)

- Exhaust port is visible as a small red spot in the top-right corner of the engine red spot.

Ž Vehicle tracks are visible with a small gap separating the vehicle's left track red spot from the engine's red spot.

- Turret is not visible at long range.

(3) *Effects of motion:*

(a) Changing target views often reveal more features.

(b) Direction of movement denotes the engine location.

(c) Transport system becomes warmer and more visible.

(d) Bouncing is slower than that of a light vehicle.

(e) Exhaust plume location and direction are sometimes visible.

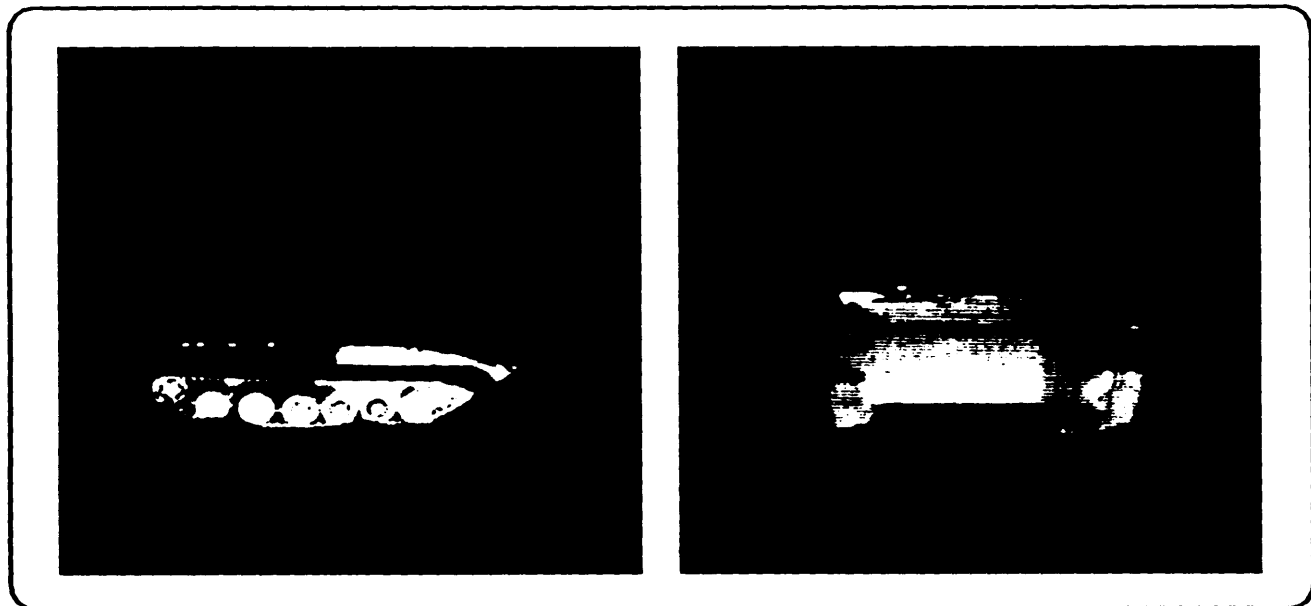

Figure A-6. BMP infantry combat vehicle.

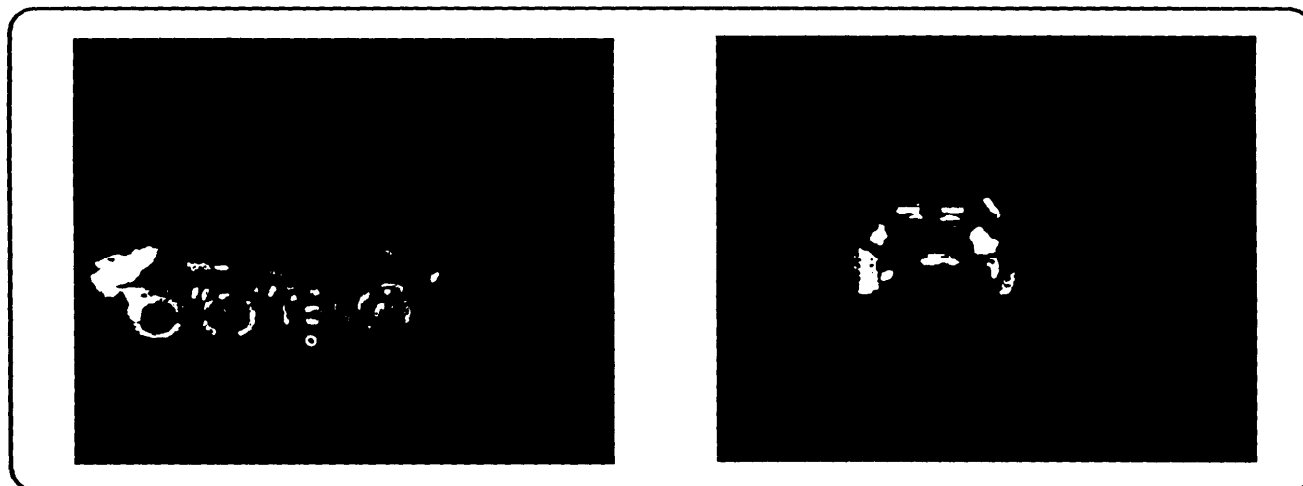

Figure A-7. BTR-60 armored personnel carrier.

g. **BTR-60 Armored Personnel Carrier** (Figure A-7).

(1) *Classification:*

(a) Side view shows distinguishable rear engine and multiple wheels at long range.

(b) Mufflers on rear deck intensify rear-engine compartment cue.

(c) Long, high profile apparent even at long ranges.

(d) Gun tube is visible when it has been recently fired.

(2) *Identification:*

(a) Side view cues:

Ž Rear engine is brightest spot on the image.

- Four (each side) large inflatable tires with a gap between front and rear pairs.

- Two mufflers mounted over the rear engine compartment.

- Small turret visible at medium range and sometimes at long range.

Ž Left and right side views are the same.

(b) Front view cues:

- This vehicle's front view shows variation in the temperature across its surface, indicating multiple shapes. There is a pattern to this temperature variation.

- Front view reveals the vehicle's rounded hull shape.

- Surfboard is cool and divides the top and bottom halves of the front hull.

Ž Normally, the front is relatively cool. A hot front indicates use of the personnel heater.

Ž Area of shock absorbers is visible at medium ranges.

(3) *Effects of motion:*

(a) Changing target views reveal more features.

(b) Wheels become warm.

(c) Engine becomes hotter.

(d) Mufflers sometimes become hot.

(e) Engine sometimes emits exhaust plume.

(f) Vehicle's large size is apparent on rough terrain by slow bounce characteristics.

NOTE: In front three-fourths view, some engine muffler heat merges with front hull and wheel heat. Therefore, this view may be more confusing than others.

h. **BRDM-2 Reconnaissance Vehicle** (Figure A-8).

(1) *Classification:*

(a) Rear-engine vehicle and exhaust.

(b) Wheel pattern of separate wheeled-size red spots.

(c) Overall profile of hull with (or without) turret.

(d) Gun tube is visible when it has been recently fired

(2) *Identification:*

(a) Side view cues:

Ž Rear engine is clearly visible at long ranges.

Ž Two tires are clearly visible (each side). Their separation distance suggests a short, wheel-base vehicle.



Figure A-8. BRDM-2 reconnaissance vehicle.

- Two mufflers – one on each side of the top rear deck – increase the engine area hot spot.
 - Ž Overall small size of vehicle is apparent.
 - Ž Side view gives a characteristic heat pattern formed by the rear mufflers and wheels. This pattern is distinctive even at long ranges.
 - Choppy ride over rough terrain is quite noticeable even at long ranges.
 - Ž Left and right views are the same.
- (b) Front view cues:
- Ž Two warm tires are separated by a cool hull. The red spot of the differential may be visible between the front tires.
 - The cool front hull denotes a rear-engine vehicle.
- NOTE: Entire frontal area may be made to appear hot, if the control is set on high.**
- Ž Dark surfboard is visible across the front of the hull.
 - Ž Tires are set closer together than tracks of most armored vehicles.
 - Ž The frontal aspect of the vehicle appears to have a higher height-to-width ratio than armored vehicles that appear wider and lower.
- Over rough terrain, the vehicle tends to bounce more than armored vehicles.
- (3) *Effects of motion:*
- (a) Changing target views often reveal more features.
 - (b) Direction of movement denotes engine location.
 - (c) Transport system becomes warmer and more visible.
 - (d) Exhaust plume location and direction are sometimes visible.

PERFORMANCE TEST

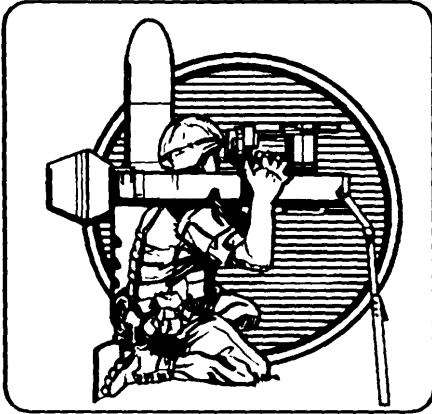

To set up at the test site, provide all the equipment and information stated in the task conditions statement.

B-1. EVALUATION PREPARATION

Brief the soldier. Tell the soldier that he will be required without error to perform all the actions to complete each task being tested.

B-2. TEST ADMINISTRATION

Tests are to be administered by the instructor/trainer. The instructor/trainer will –

- Ž Sign each score sheet.
- Ž Record results on the Dragon performance scorecard (Appendix C).

- Ž Provide added training on each task failed, and retest twice.
- Ž Eliminate soldiers that fail any task after three attempts.

The following training objectives (Figures B-1 through B-11) are suggested formats only. They must be modified IWA local requirements.

Training Objective 1

TASK: Identify Armored Vehicles (Visually With Daysight).

CONDITIONS: In a garrison or field environment in which armored vehicles are visible in a tactical or a simulated tactical setting. Given a Dragon day tracker mated to a simulated round of ammunition (FHT), and prepared for firing.

STANDARDS: Within two minutes, recognize 10 out of 10 vehicles as friendly or Threat.

Evaluation Preparation:

Setup: If actual or 1:35-scale vehicles are unavailable, the basic visual CVI program, GTA 17-2-13, shows multiple views of 30 friendly and Threat armored vehicles that every soldier should know. Present any six Threat and any four friendly armored vehicles to the soldier. Present each picture to the student for 10 seconds.

Brief student: Tell the soldier that he will see pictures of 10 armored vehicles for 10 seconds each. During the 10-second viewing, the soldier must indicate whether the vehicles are friendly or Threat. "Are there any questions?"

Answer student questions. If the student still does not understand, tell him, "Do the best you can. "

Performance Measures:

GO

NO-GO

NO-GO

NO-GO

Recognized 10 out of 10 armored vehicles as friendly or Threat.

✓

✓

INSTRUCTOR'S SIGNATURE

William P. Platzell

STUDENT'S INITIALS GO

JLz

STUDENT'S INITIALS NO-GO

JLz

STUDENT'S INITIALS NO-GO

STUDENT'S INITIALS NO-GO

Figure B-1. Suggested format for Training Objective 1.

Training Objective 2

TASK: Explain Emergency Destruction Procedures on a Dragon.

CONDITIONS: Given a simulated situation in which capture is imminent, and a destruction order to destroy your tracker and rounds of ammunition.

STANDARDS: Explain the method of destruction for Dragon components and ammunition.

Evaluation Preparation:

Read: "When I say 'begin,' you must explain emergency destruc-

tion procedures on a Dragon. Are there any questions? "

Answer student questions. If the student still does not understand, tell him, "Do the best you can."

Performance Measures:

GO

NO-GO

NO-GO

NO-GO

NOTE: Priority: tracker, then round.

1. Tracker.
 - a. Mechanical. Used an entrenching tool, axe, sledgehammer, and so on.
 - b. Gunfire.
 - c. Burning. Used flammable material or gasoline.
 - d. Explosives. Used a double-primed explosive charge.
2. Round. Destroyed a round of ammunition by either –
 - a. Burning. Used flammable material, thermite grenade, or gasoline.
 - b. Explosives. Used a double-primed explosive charge. (Squad leader will prepare explosives.)
 - c. Launching. Fired the missile, then drove over the expelled launcher.

✓

✓

INSTRUCTOR'S SIGNATURE

William J. Blatz

STUDENT'S INITIALS GO

JL

STUDENT'S INITIALS NO-GO

STUDENT'S INITIALS NO-GO

STUDENT'S INITIALS NO-GO

Figure B-2 Suggested format for Training Objective 2.

Training Objective 3

TASK: Maintain the Medium Antitank Weapon.

CONDITIONS: Given Dragon trackers and a round of ammunition. (For all tasks, the FHT will be used instead of an actual round.)

STANDARDS: Conduct a complete before-operation check of the Dragon trackers and a round of ammunition.

Evaluation preparation:

Read: "When I say 'Begin,' you must conduct a before-operation check of the Dragon trackers and a round of ammunition. Are there any questions?"

Answer student questions. If the student still does not understand, tell him, "Do the best you can."

INSTRUCTOR NOTE: Because of the common parts on the day and night trackers, the student may only mention the items on the night tracker or the day tracker. If he mentions it on one or the other, give him a GO.

WARNING: Never perform a before-operation check of the Dragon trackers if they are mated to a round of ammunition.

Performance Measures:	GO	NO-GO	NO-GO	NO-GO
1. Day Tracker.			✓	
a. Pushed safety plunger.				
b. Squeezed trigger lever bar.				
c. Ensured safety was functional and trigger clicked.			✓	
2. Guide Pins.	✓			
Z Looked for the guide pins and ensured they were tight, present, and four each.				
3. Connector.	✓			
a. Checked connector cover for rubber seals.				
b. Ensured connector was clean.				
c. Ensured connector was not damaged.				
4. Tracker Housing.	✓			
a. If damaged, reported to supervisor.				
b. Spot-painted, when needed.				

Figure B-3. Suggested format for Training Objective 3.

Performance Measures:	GO	NO-GO	NO-GO	NO-GO
5. Eye Guard.	✓			
Ž Rotated the eye guard.	✓			
6. Night Tracker.				
a. Checked range focus lever.				
b. Checked for freedom of movement.	✓			
7. Optics (same as day tracker).				
Ž Cleaned the lenses.	✓			
8. ACTUATOR Switch.				
a. Rotated the actuator switch to the AIR-BATTERY check.				
b. Checked the coolant cartridge/ battery monitor.				
c. Ensured the reticles were illuminated.				
d. Rotated the ACTUATOR switch to the ON position.				
e. Waited 15 seconds.				
f. Removed the lens cover.				
9. Infrared Contrast.				
a. Selected an object with infrared contrast.				
b. Adjusted the reticle focus.				
c. Adjusted brightness.				
d. Adjusted contrast.				
e. Adjusted range focus.				
f. Rotated the ACTUATOR switch to the OFF-LOCK position.				
g. Did not turn the ACTUATOR switch to the RELEASE position.				
h. Replaced the lens cover.				
10. Ammunition Round.				
a. Checked the exterior for dirt, oil, and grease.				
b. Checked the exterior for dents, holes, and punctures.				
11. Raceway.				
Ž Ensured raceway was not damaged.				

Figure B-3. (Continued.)

INSTRUCTOR'S SIGNATURE
STUDENT'S INITIALS GO
STUDENT'S INITIALS NO-GO
STUDENT'S INITIALS NO-GO
STUDENT'S INITIALS NO-GO

William Pletzell
JP
JP

Figure B-3. (Continued.)

Training Objective 4

TASK: Prepare the Medium Antitank Weapon for Firing.

CONDITIONS: Given a Dragon tracker in the carrying bag and a round of ammunition in the carrying configuration.

STANDARDS: Mate the tracker to the round of ammunition IAW the performance measures described herein.

Evaluation Preparation:

Read: "When I say 'Begin,' you will prepare the Dragon for firing by

mating the tracker to the round of ammunition. Are there any questions?"

Answer student questions. If the student still does not understand, tell him, "Do the best you can."

Performance Measures:	GO	NO-GO	NO-GO	NO-GO
1. Prepare the Round.	✓			
a. Unsnapped biped retaining strap.				
b. Lowered bipod to VERTICAL-LOCK position. (Shook bipod and ensured it was locked.)				
c. Depressed friction lock and extended legs about one-half way down.				
d. Removed the electrical connector cover from the round.				
2. Prepared the Day Tracker.	✓			
a. Removed the tracker properly.				
b. Removed electrical connector cover.				
c. Checked lenses.				
3. Mated the Tracker to the Round.	✓			
a. Aligned the guide pins with the tracker support assembly and locked the tracker in place. (Shook tracker to ensure it was locked.)				
b. Leveled sight picture. (Adjusted the bipod friction lock and the foot adjust.)				

INSTRUCTOR'S SIGNATURE *William P Platzell*
 STUDENT'S INITIALS GO *js*
 STUDENT'S INITIALS NO-GO
 STUDENT'S INITIALS NO-GO
 STUDENT'S INITIALS NO-GO

Figure B-4. Suggested format for Training Objective 4.

Training Objective 5

TASK: Restore the Medium Antitank Weapon to Carrying Configuration.

CONDITIONS: Given a Dragon tracker, carrying bag, and round of ammunition.

STANDARDS: The tracker and round are properly returned to the carrying configuration without damage to the equipment.

Evaluation Preparation:

Read: "When I say 'begin,' you will restore the Dragon to the carrying

configuration. Are there any questions?"

Answer student questions. If the student still does not understand, tell him, "Do the best you can. "

Performance Measures:

GO

NO-GO

NO-GO

NO-GO

1. Removed and Stored the Tracker.
 - a. Removed the tracker.
 - b. Released the spring clip.
 - c. Removed from support assembly.
 - d. Replaced the lens cover.
 - e. Replaced electrical cover.
 - f. Placed tracker in the carrying bag.
- 2 Restored the Round of Ammunition.
 - a. Replaced the connector cover.
 - b. Collapsed the biped legs.
 - c. Replaced the shock absorber.
 - d. Secured legs to the round.

INSTRUCTOR'S SIGNATURE *William P. Hobell*
 STUDENT'S INITIALS GO *JL*
 STUDENT'S INITIALS NO-GO *JL*
 STUDENT'S INITIALS NO-GO
 STUDENT'S INITIALS NO-GO

Figure B-5. Suggested format for Training Objective 5.

Training Objective 6

TASK: Assume Correct Dragon Firing Positions.

CONDITIONS: Given a Dragon tracker and round of ammunition already mated.

STANDARDS: Correctly assume the four correct firing positions for the Dragon.

Evaluation Preparation:

Read: "When I say 'Begin,' you will assume the four firing positions for the Dragon. You will be tested on all four positions. After you are in the correct position, tell me, and I will inform you if you are a GO or

NO-GO in that position. Do you have any questions?"

Answer student questions. If the student still does not understand, tell him, "Do the best you can."

Performance Measures:

GO

NO-GO

NO-GO

NO-GO

1. Sitting Position.

- a. Sat down, feet on bipod. Pushed legs out.
- b. Leaned forward and placed round on the meaty portion of shoulder, keeping the upper body straight.
- c. Properly grasped the tracker with both hands.
- d. Rotated head and aligned right eye in the eye guard. Pushed head forward.
- e. Pulled elbows in and back and tried to touch them together and put them on the chest. Removed slack from the bipod.

✓

2. Standing Supported.

- a. Stood with legs spread comfortably apart. Legs straight, but not locked.
- b. Leaned forward. Rested the abdomen against the edge of the fighting position.
- c. Placed Dragon on the meaty part of the shoulder. (Placed bipod legs far forward.)
- d. Placed hands as for the sitting position.
- e. Rotated head and right eye as in the sitting position.

✓

Figure B-6. Suggested format for Training Objective 6.

Performance Measures:

GO

NO-GO

NO-GO

NO-GO

f. Removed slack from the bipod. Pulled down and back. Tried to touch the elbows and drive them into the chest. If there was slack in the bipod, straightened the back slightly.

✓

3. Kneeling Position.

a. Kneeled with knees spread comfortably apart.

b. Placed the bipod well out in front and removed slack from the bipod by rocking backward. Attempted to sit on heels.

c. Rotated head and right eye as in the sitting position.

d. Placed hand and elbows the same as in the sitting position.

✓

4. Prone Position.

(The round is in a prepared-to-fire mode.)

a. Laid down at a 90-degree angle to the direction of fire.

b. Positioned the Dragon so the bipod laid on the right bicep. Curled right arm up and grasped firing mechanism.

c. Placed left hand on the tracker.

d. Pulled the round into the curve of the neck.

e. Placed right eye in the eye guard and pressed head forward to keep eye from closing.

f. Kept the front and rear of the Dragon 6 inches off the ground.

INSTRUCTOR'S SIGNATURE

William P. Platyell

STUDENT'S INITIALS GO

jsz

STUDENT'S INITIALS NO-GO

STUDENT'S INITIALS NO-GO

STUDENT'S INITIALS NO-GO

Figure B-6. (Continued.)

Training Objective 7

TASK: Determine Target Engageability.

CONDITIONS: Given a Dragon tracker mated to a round of ammunition and targets (scale or actual targets).

STANDARDS: Correctly determine if three targets are in range and engageable.

Evaluation Preparation:

Read: "When I say 'Begin,' you will determine if the targets are in range and if they are engageable. To your front are armored vehicles at

varying (simulated) ranges. Then, you must accurately determine the engageability of all three targets. Are there any questions."

Answer student questions. If the student still does not understand, tell him, "Do the best you can."

Performance Measures:

GO

NO-GO

NO-GO

NO-GO

Target Engageability.

a. Determine if the target is in range or out of range; engageable or nonengageable.

Target Number __, __, __.

b. In range or out of range; engageable or nonengageable.

Target Number __, __, __.

c. In range or out of range; engageable or nonengageable.

Target Number __, __, __.

INSTRUCTOR'S SIGNATURE *William P. Plattell*
 STUDENT'S INITIALS GO *glw*
 STUDENT'S INITIALS NO-GO *glw*
 STUDENT'S INITIALS NO-GO
 STUDENT'S INITIALS NO-GO

Figure B-7. Suggested format for Training Objective 7.

Training Objective 8

TASK: Perform Immediate Action Procedures.

CONDITIONS: Given a Dragon tracker mated to a round of ammunition and a malfunction situation.

STANDARDS: Perform the proper immediate-action procedures for a hot and cold tracker battery.

Evaluation Preparation:

Read: "When I say 'Begin,' you will perform immediate-action

procedures for the Dragon. Do you have any questions?"

Answer student questions. If the student still does not understand, tell him, "Do the best you can."

Performance Measures:

GO NO-GO NO-GO NO-GO

1. Immediate-Action Procedures (Hot Tracker Battery).
 - a. Attempted to fire; failed to fire.
 - b. Immediately resqueezed the trigger/tack for 15 seconds.
 - c. Sounded off with "Misfire," if round still did not fire.
 - d. Cautiously turned and felt in the vicinity of the tracker battery (HOT).
 - e. Removed the tracker and placed the round a safe distance away.
 - f. Obtained a new round and mated the tracker to the round.
 - g. Acquired the target, said "I am continuing my mission" or squeezed the trigger.
 - h. Squeezed the trigger.
2. Cold Tracker Battery.
 - a. Attempted to fire; failed to fire.
 - b. Immediately resqueezed the trigger/tack for 15 seconds.
 - c. Cautiously turned and felt in the vicinity of the tracker battery (COLD).
 - d. Released the tracker and moved it forward; reseated the tracker on the round.

✓ (under a)

 ✓ (under d)

 ✓ (under h)

 ✓ (under c)

 ✓ (under d)

Figure B-8. Suggested format for Training Objective 8.

Performance Measure	GO	NO-GO	NO-GO	NO-GO
e. Acquired the target, said "I am continuing my mission" or squeezed the trigger.				
f. Failed to fire; checked battery again (COLD).				
g. Removed tracker; placed round a safe distance away.				
h. Got a new round and said "I will continue the mission."				
i. Failed to fire; checked the battery (COLD).				
j. Replaced the tracker.				
INSTRUCTOR'S SIGNATURE	<i>William P. Platell</i>			
STUDENT'S INITIALS GO	<i>JL</i>			
STUDENT'S INITIALS NO-GO	<i>JL</i>			
STUDENT'S INITIALS NO-GO				
STUDENT'S INITIALS NO-GO				

Figure B-8. (Continued.)

Training Objective 9

TASK: Prepare an Antiarmor Range Card.

CONDITIONS: Given the standard range card and squad leader's briefing containing all pertinent data.

STANDARDS: Within 15 minutes, complete the antiarmor range

card. Include all data from the squad leader's briefing, marginal data, a scaled-down sketch of the terrain, and the data section.

Evaluation Preparation:

Read: "When I say 'Begin,' you will have 15 minutes to complete the antiarmor range card, including the

data section and terrain sketch. Do you have any questions?"

Answer student questions. If the student still does not understand, tell him, "Do the best you can."

Performance Measures:

GO

NO-GO

NO-GO

NO-GO

1. Prepared an Antiarmor Range Card (Marginal Information).

- a. Unit designation.
- b. Magnetic north.

2. Terrain Sketch.

- a. Left limit.
- b. Right limit.
- c. Maximum engagement line.
- d. Terrain features.
- e. Dead space.
- f. Target reference point(s).
- g. Gunner reference point.

3. Data Section.

- a. Position.
- b. Date.
- c. Weapon symbol.
- d. Meter increments.
- e. Item numbers.
- f. Direction.
- g. Range.
- h. Description.
- i. Remarks.

4. Made two copies of the range card.



Figure B-9. Suggested format for Training Objective 9.

INSTRUCTOR'S SIGNATURE *William P. Stahel*
STUDENT'S INITIALS GO *JL*
STUDENT'S INITIALS NO-GO *JL*
STUDENT'S INITIALS NO-GO
STUDENT'S INITIALS NO-GO

Figure B-9. (Continued.)

Training Objective 10

TASK: Construct a Dragon Fighting Position.

CONDITIONS: Draw a fighting position; label the six main components of the fighting position.

STANDARDS: Within 10 minutes, correctly draw and label the components of a fighting position.

Evaluation Preparation:

Read: "When I say 'Begin,' you will have 10 minutes to draw a

complete fighting position. Do you have any questions?"

Answer student questions. If the student still does not understand, tell him, "Do the best you can."

Performance Measures:	GO	NO-GO	NO-GO	NO-GO
1. Trench.		✓		
a. Three M16s long, inverted V.		✓	✓	
b. Waist deep.				
c. Waist wide plus 6 inches.				
2. Front Parapet.		✓		
a. One M16 long.			✓	
b. One M16 wide.		✓		
c. Two helmets high.		✓		
3. Flank Parapet,				
a. One M16 wide.				
b. Two helmets high.				
c. Long enough to provide good flank protection.				
4. Biped Trench.		✓		
a. Two helmets long.				
b. One helmet wide.				
c. Six inches deep (one bayonet blade).	✓			
5. Grenade Sump.				
a. One entrenching tool-length long.				
b. One entrenching tool-length deep.				
c. One entrenching tool-blade wide.				

Figure B-9. Suggested format for Training Objective 10.

Performance Measures:

GO

NO-GO

NO-GO

NO-GO

6. Overhead Cover.

a. Each end of the trench.

b. Dug 12 inches deep.

c. Eighteen inches longer than the side of the trench.

d. Three feet wide.

e. The hole under the overhead cover is large enough for one soldier and extra ammunition.

✓

✓

INSTRUCTOR'S SIGNATURE

William P Platzell

STUDENT'S INITIALS GO

JL

STUDENT'S INITIALS NO-GO

JL

STUDENT'S INITIALS NO-GO

JL

STUDENT'S INITIALS NO-GO

Figure B-10. (Continued.)

Training Objective 11

TASK: Decontaminate the Medium Antitank Weapon.

CONDITIONS: Given the Dragon trackers and round of ammunition (for all tasks, the FHT is used instead of an actual round), M8 paper, M256 detector kit, M258A1 kit, hot, soapy water, lens tissue, camel's-hair brush, and ethyl alcohol.

STANDARDS: Correctly explain the decontamination procedures for the Dragon trackers and round of ammunition.

Evaluation Preparation:

Read: "When I say 'Begin,' you will correctly explain how to decontaminate the Dragon

trackers and round of ammunition. Do you have any questions?"

Answer student questions. If the student still does not understand, tell him, "Do the best you can."

Performance Measures:

GO

NO-GO

NO-GO

NO-GO

INSTRUCTOR'S NOTE: First, the leader decides whether or not the Dragon needs to be immediately decontaminated. If the gunner is already in MOPP4 and the threat is imminent, decontamination will have to be postponed. If the gunner is to be displaced to a noncontaminated area, the decision to immediately fire the missile, or try to decontaminate it for transport, must be made. (Inform the soldier of the type of decontamination: nuclear, chemical, or biological.)

1. Nuclear Decontamination.
 - a. Thoroughly brushed clothing and equipment to remove fallout (away from the position).
 - b. Turned over the soil in the immediate area around the position.
 - c. Verified decontamination with the AN/PDR-27 radiaometer.
2. Biological Decontamination.
 - a. Washed the Dragon with warm, soapy water.
 - b. Dried the Dragon.
 - c. Used normal cleaning procedures for the lenses.



Figure B-11. Suggested format for Training Objective 11.

GUNNER QUALIFICATION/ VERIFICATION WITH LET

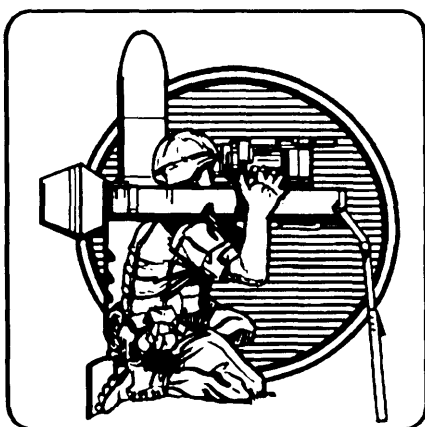

Gunners who have not qualified can be awarded the ASI of C2 on the successful completion of the gunner qualification program. Qualification consists of completing the training outlined in Chapter 6 to include passing the performance tests and qualification firing with the LET. Verification is the requirement for a gunner to verify quarterly so that he can still achieve the minimum qualification standards.

C-1. REQUIREMENTS

After an award of ASI of C2, each gunner fires a minimum of two tables, sitting and standing supported, before trying to verify his

qualification. If any gunner does not verify on his first try, he is given two more tries. Gunners failing to verify after three tries should have their

ASI of C2 revoked. Gunners are classified as expert or 1st class (Table C-1) based on their firing performance.

GUNNER'S CLASSIFICATION	GUNNER'S SCORE
Expert	36 to 40
1st Class	32 to 35
Unqualified	0 to 31

Table C-1. Gunner classification.

TABLE	FIRING POSITION	SIGHT	MINIMUM STANDARD
1	Sitting	DayTracker	
2	Standing Supported	Day Tracker	16 out of 20
1	Sitting	Night Tracker	
2	Standing Supported	Night Tracker	16 out of 20

Table C-2. Minimum standards.

The gunner’s performance is recorded by events on the Dragon performance scorecard. Each event is made up of 20 shots (engage-

ments). Each gunner must achieve the minimum standards in Table C-2 to either qualify for award of the

ASI of C2 or to verify his qualification.

C-2. INSTRUCTOR GUIDELINES

The instructor at each firing position must adhere to the following guidelines:

- Ž Boresights the monitoring set(s) each time the range setting is changed. Checks the battery power.
- Ž Ensures the gunner takes the slack out of the biped, and

- keeps his eye against the eye guard.
- Ž Tells the gunner to use a smooth tracking rate, and follows through until the engagement is ended.
- Ž Fires all engagements in sequence.
- Ž Fires all engagements with M64 cartridges.

- Ž Scores a MISS if the gunner does not hold down on the tracker and round, and does not keep the eye against the rubber eye guard.
- Ž Totals the number of HITS or MISSES and enters the results on the Dragon performance scorecard.

C-3. FIRING PROCEDURES

Dragon launch characteristics are simulated during qualification/ verification firing by having the gunner fire and track with the M64 cartridge and LET. This helps prepare the gunner for an actual missile launch by simulating –

- Ž Time delay after trigger depression (.6 seconds).
- Ž Noise.
- Ž Backblast (50 meters).

The monitoring set can duplicate targets out to 1,000 meters. During qualification and verification, gunners are required to track from 1 to 10 seconds, depending on the range setting.

C-4. SCORECARD AND FIRING TABLES

The Dragon performance scorecard, DA Form 4242-1-R, is used for 'instructional firing, field

firing, qualification firing, LES firing, and recording performance

test results. See Figure C-1 for an example format.

DRAGON PERFORMANCE SCORECARD

For use of this form, see FM 23-24. The proposed agency is TRADOC.
 DATA REQUIRED BY EXECUTIVE ORDER 12958: PRINCIPAL PURPOSE: Evaluate individual's training on targets of varying ranges. INCENTIVE USES: Evaluate individual proficiency. ESN is used for positive identification purposes only. MANDATORY OR VOLUNTARY DISCLOSURE AND EFFECT ON INDIVIDUAL: NOT PROVIDING INFORMATION: Voluntary. Individuals not providing information cannot be considered on a mass basis.

Authority: 10 USC 3012a(5) Executive Order 12958: PRINCIPAL PURPOSE: Evaluate individual's training on targets of varying ranges. INCENTIVE USES: Evaluate individual proficiency. ESN is used for positive identification purposes only. MANDATORY OR VOLUNTARY DISCLOSURE AND EFFECT ON INDIVIDUAL: NOT PROVIDING INFORMATION: Voluntary. Individuals not providing information cannot be considered on a mass basis.

LAST NAME	FIRST	MI	SSN	TEST 1	TEST 2	TEST 3	RANK
W. H. P. L. S.	W. H. P. L. S.	T	73-45-6789	GO NO-GO	GO NO-GO	GO NO-GO	E-5
UNIT	TEST DATE	RETEST DATE					
A-1-13	2 JAN 94	5 JAN 94					
1. MAINTAIN THE M47 MEDIUM ANTITANK WEAPON				✓	✓		
2. PREPARE THE M47 FOR FIRING				✓			
3. RESTORE THE M47 TO CARRYING				✓			
4. DEMONSTRATE CORRECT FIRING POSITIONS				✓			
5. DETERMINE IF TARGETS ARE ENGAGEABLE				✓			
6. PERFORM IMMEDIATE-ACTION PROCEDURES					✓	✓	
7. PREPARE AN ANTIARMOR RANGE CARD				✓			
8. CONSTRUCT A FIGHTING POSITION				✓			
9. IDENTIFY ARMORED VEHICLES					✓	✓	
10. EXPLAIN EMERGENCY DESTRUCTION PROCEDURES							
11. EXPLAIN EMERGENCY DECONTAMINATION PROCEDURES							

NOTES: 1. The instructor and Dragon gunners must pass all tasks.
 2. A student should be eliminated from training if he fails to meet performance standards on any task after three attempts.
 3. The instructor places his initials in the GO, NO-GO column.

TEST NO.	QUALIFIED	UNQUALIFIED	INSTRUCTOR'S SIGNATURE
TEST 1		NRO	<i>William R. Schmidt</i>
TEST 2		NRO	
TEST 3	NRO		

DA Form 4242-1-R FEB 90

Figure C-1. Example of completed Dragon performance scorecard.

DECONTAMINATION AND DESTRUCTION PROCEDURES

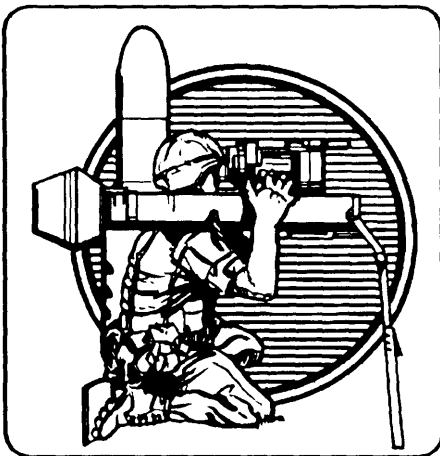

Decontamination procedures must be developed and maintained to provide units with the ability to accomplish their missions in possible NBC environments. Destruction of the Dragon within the combat zone is ordered to prevent enemy capture and use. When destruction of the Dragon is necessary, it is IAW orders from or policy established by the commander.

D-1. DECONTAMINATION PRINCIPLES

Decontamination is the removal or neutralization of a hazardous level of NBC contamination from personnel and material.

a. Whenever NBC contamination of the Dragon system occurs, the operator must decide first whether or not to decontaminate. Nuclear contamination (fallout) should be

removed as soon as possible. However, as long as the operator wears the required protective equipment, he could carry and fire a Dragon with chemical or biological contamination. If this occurs, soldiers should exchange their MOPP gear for a new set IAW unit SOPS.

b. Attempts to reduce chemical or biological contamination can be hindered by the exposed rubber-like and plastic components of the Dragon because the agents soak into these materials. Therefore, the objective of decontamination should be to remove or reduce it only on those surfaces the operator touches.

D-2. PROCEDURES

Dragon components contaminated with chemical agents are best

decontaminated by airing. Remove or blot extra liquid agents from all

components and place the equipment outdoors in the sun.

Periodically, test the equipment with M8 detector paper and M256 detector kit to determine when the Dragon is safe to handle. (See FM 3-5 for more detailed information.) To quickly reduce chemical decontamination on Dragon surfaces, the gunner can use hot, soapy water or an M258A1 kit. If water is used, do not submerge the Dragon or the tracker. Clean the optics, using a camel's-hair brush, ethyl alcohol, and lens paper.

NOTE: Standard decontaminants, DS2 and STB, should not normally be used since they can

damage sensitive electronic components of the Dragon weapon system.

a. Biological decontamination procedures must adhere to the following guidelines:

- (1) Wash the Dragon with warm, soapy water.
- (2) Dry the Dragon.
- (3) Clean optics with lens cleaning solvents (or ethyl alcohol) and lens paper.

b. Nuclear decontamination procedures (after fallout has

stopped) must adhere to the following guidelines:

- (1) Brush clothing and equipment thoroughly to remove fallout. (This should be performed away from the position.)
- (2) Decontaminate individual equipment by brushing, wiping, and scrubbing.
- (3) Decontaminate the immediate area around the position by turning over the soil.
- (4) Verify that the Dragon is decontaminated with the AN/PDR-27 radiometer.

D-3. DESTRUCTION GUIDANCE

The information that follows is only for guidance. Certain outlined procedures require the use of explosives that may not be authorized items. The issue of these and related materials and conditions for destruction are command decisions. Destruction of Dragon components by mechanical means, explosives, gun fire, or burning makes them useless to the enemy. If evacuation of the Dragon is not possible, the components are

destroyed with the following priority: first the tracker, then the round. Destroying the same components in all weapons prevents the enemy from assembling a complete Dragon by cannibalizing useable components.

a. If destruction is ordered, a location for destruction is selected that will cause the greatest obstruction to enemy movement and not create a hazard to friendly soldiers.

b. Each organization and installation that uses, maintains, or stores the missiles or trackers should have an SOP for destruction. The procedure should contain priorities of destruction, methods of destruction, quantities of explosives required, and instructions for destruction. The destruction plan should be flexible enough to cover any situation.

D-4. DESTRUCTION OF TRACKER

The tracker may be destroyed by one of the following methods.

a. **Explosive.** A double-primed explosive charge (at least 1/2 pound) is prepared and placed on top of the tracker; detonate either electrically or nonelectrically.

b. **Gunfire.** Well-aimed shots from a rifle, or other small-arms, will make

the tracker useless to the enemy. When using small-arms fire aim for critical parts such as the optics, trigger assembly, and the electronics package.

c. **Mechanical.** The tracker is smashed with axes, picks, crowbars, rock, and so on, or driven over with a tracked vehicle. It is completely

destroyed if enough time and personnel are available.

d. **Burning.** After maximum damage has been done to the tracker by other destructive methods, set fire to the resulting debris, if time allows. Vehicle fuels and lubricants are used to complete the destruction by burning.

D-5. DESTRUCTION OF ROUND

The missile can be destroyed by the following methods.

WARNING: Do not attempt to destroy live missiles by mechanical methods.

a. **Launching.** The simplest and most effective method of destroying the missile is to fire it into enemy territory. The launcher must be smashed with axes, picks, and so on, or driven over with a tracked vehicle after firing the missile.

b. **Explosives.** The use of explosives not only destroys the missile, but also the launcher. One-half pound of explosive placed on the round close to the warhead should destroy the round (Figure D-1).

(1) Determine whether electrical blasting caps and wire, or nonelectric blasting caps and safety fuses can be used for priming and detonating the explosive charges. If nonelectric caps are used, they must be crimped to at least a 2-meter length of safety fuse.

WARNING: The safety fuse burns at the rate of 1 foot in 30 to 40 seconds. The safety fuse which contains black powder and blasting caps, must be protected from moisture at all times.

(2) Connect the charges with detonating cord to produce a

simultaneous detonation. Dual-prime the charges to reduce the possibility of a misfire.

WARNING: The blasting caps, detonating cord, and safety fuses must be kept separate from the charges until required for use.

(3) If the charges are primed with nonelectric blasting caps, ignite the safety fuses and take cover at once. If the charges are primed with electric blasting caps, take cover before firing.

WARNING: The live rocket motors and high-explosive antitank warhead present a hazard to soldiers firing at the missile; therefore, small-arms fire should not be used.

c. **Burning.** After maximum damage has been done to the components by other destruction methods, and if time permits, the debris must be burned. Vehicle fuels and lubricants can be used to aid burning. One or more incendiary grenades can be placed on each part.

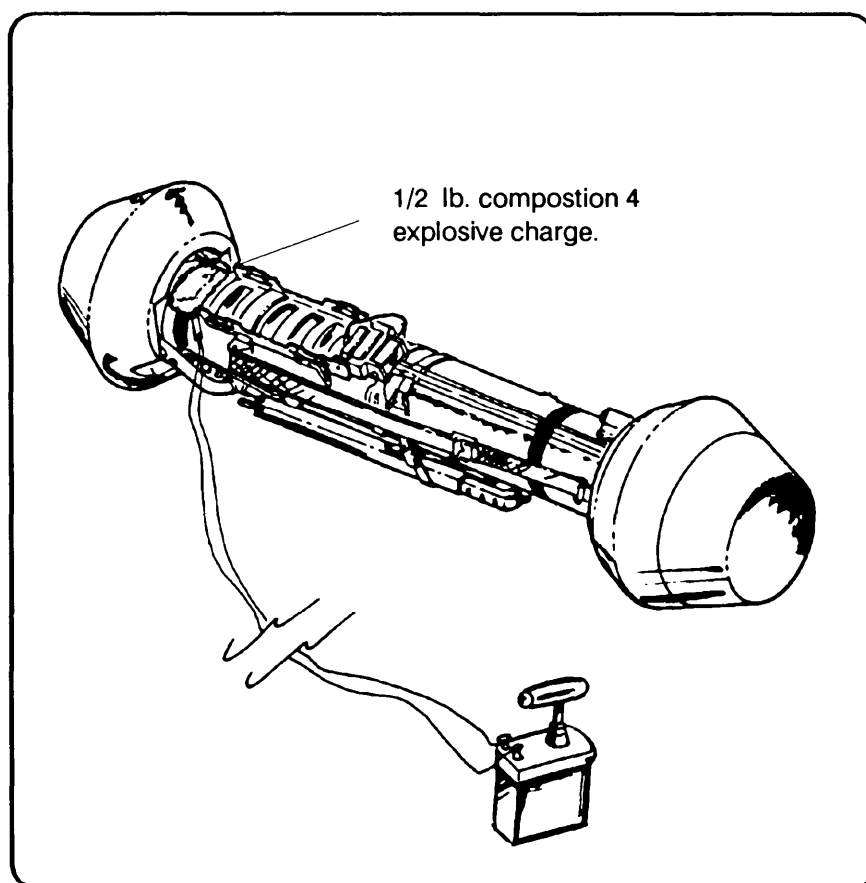

Figure D-1. Explosive charge on a round.

GLOSSARY

ACRONYMS AND ABBREVIATIONS

amp	ampere
APC	armored personnel carrier
AR	Army regulation
ARTEP	Army Training and Evaluation Program
ASI	additional skill identifier
asst	assistant
ATGM	antitank guided missile
ATWESS	antitank weapon effect simulator system
BFV	Bradley fighting vehicle
BMP	(a Threat vehicle)
BRDM	(a Threat scout car)
BTR	(a Threat vehicle)
C2	command and control
CB	citizen's band (radio)
cbt	combat
CFV	cavalry fighting vehicle
CP	command post
CPX	command post exercise
CS	combat support
CTA	common table of allowances
CVI	combat vehicle identification
DA	Department of the Army
dir	direction
DLIC	detachment left in contact
DZ	drop zone
EOD	explosive ordnance disposal
1SG	first sergeant
F	Fahrenheit
FASCAM	family of scatterable mines
FHT	field handling trainer
FIST	fire support team
FM	field manual
FOV	field of view

FM 23-24

FPF	final protective fire
FPL	final protective line
FSO	fire support officer
FTX	field training exercise
gnr	gunner
GTA	graphic training aid
HE	high explosive
HMMWV	high-mobility multipurpose wheeled vehicle
horz	horizontal
HQS	headquarters
hrs	hours
Hz	Hertz
IAW	in accordance with
illus	illustration
IR	infrared
KHz	kilohertz
kmph	kilometers per hour
LAW	light antitank weapon
LD	line of departure
ldr	leader
LES	launch environment simulator
LFX	live-fire exercise
LET	launch effects trainer
LOS	line of sight
LP	listening post
L-R	left to right
LTID	laser target interface device
M	monthly
MAPP	methylacetylene propadiene, propane propylene
mech	mechanized
mi	middle initial
MI	military intelligence
MILES	multiple integrated laser engagement system
min	minute(s)
mm	millimeter
mod	model
mon	monitor
MOUT	military operations on urbanized terrain
mph	miles per hour
MQS	military qualification standards
MTP	mission training plan
NA	not applicable
NATO	North Atlantic Treaty Organization
NAVTRADEV	Naval training development
NBC	nuclear, biological, and chemical

NCO	noncommissioned officer
NCOES	Noncommissioned Officer Education System
NCOIC	noncommissioned officer in charge
nonmech	nonmechanized
NVD	night vision device
OP	observation post
OPFOR	opposing force
OSUT	one-station unit training
PDF	principal direction of fire
plt	platoon
PMCS	preventive maintenance checks and services
POI	program of instruction
PSG	platoon sergeant
psi	pounds per square inch
PSM	power supply modulator
pwr	power
Q	quarterly
qual	qualifications
qtr	quarterly
R-L	right to left
RSTA	reconnaissance, surveillance, and target acquisition
S2	Intelligence Officer
S3	Operations and Training officer
sec	section
SGT	sergeant
SL	skill level
SMCT	soldier's manual common tasks
SOP	standing operating procedure
sqd	squad
SSAN	Social Security Administration Number
STB	supertropical bleach
STP	Soldier's training publication
STX	situational training exercise
TC	training circular
tm	team
TM	technical manual
TO	training objective
TOW	tube-launched, optically tracked, wire-guided (missile)
TRADOC	United States Army Training and Doctrine Command
TRP	target reference point
TSC	Training Support Center
US	United States
USC	United States Code

FM 23-24

VAC	voltage alternating current
VDC	voltage direct current
vert	vertical
VPC	vehicle power conditioner
WP	white phosphorus
XO	executive officer

REFERENCES

REQUIRED PUBLICATIONS

Required publications are sources that users must read in order to understand or to comply with this publication.

ARMY REGULATIONS (ARs)

385-62 Regulation for Firing Guided Missiles and Heavy Rockets for Training, Target Practice and Combat

ARMY TRAINING AND EVALUATION PROGRAMS (ARTEPs)

7-8-MTP Mission Training Plan for the Infantry Rifle Platoon and Squad

DEPARTMENT OF THE ARMY FORMS (DA Forms)

5517-R Standard Range Cards (LRA)
4242-R Dragon Gunnery Scorecard
4242-1-R Dragon Performance Scorecard

FIELD MANUALS (FMs)

3-5 NBC Decontamination
7-7 The Mechanized Infantry Platoon and Squad (APC)
7-7J The Mechanized Infantry Platoon and Squad (Bradley)
7-8(HTF) The Infantry Platoon and Squad (Infantry, Airborne, Air Assault, Ranger)
(How to Fight)
7-10(HTF) The Infantry Rifle Company (Infantry, Airborne, Air Assault, Ranger)
(How to Fight)

GRAPHIC TRAINING AIDS (GTAs)

17-2-11 Combat Vehicle Identification Training Cards (CVI)
17-2-13 Armored Vehicle Recognition
25-6-9 Instructor's MILES Equipment Training Guide – Infantry

SOLDIER TRAINING PUBLICATIONS (STPs)

21-1-SMCT	Soldier's Manual of Common Tasks, Skill Level 1
21-24-SMCT	Soldier's Manual of Common Tasks, Skill Levels 2/3/4

TECHNICAL MANUALS (TMs)

9-1265-368-10-1	Operator's Manual for Multiple Integrated Laser Engagement Systems (MILES) Simulator System, Firing Laser: M62
9-1300-206	Ammunition and Explosives Standards
9-1425-484-10	Operator's Manual for Dragon Weapon Guided Missile System, Surface Attack: M47 (Medium Antitank/Assault Weapon System)
9-5855-254-14-HR	Hand Receipt Covering Content of Components of End Item (COEI) Basic Issue Items (BII), and Additional Authorization List (AAL) for Charger, Battery PP-7382/TAS
9-6920-484-12	Operator and Organizational Maintenance Manual for Guided Missile System Surface Attack, M47; Training Equipment Consisting of Monitoring Set, Guided Missile System, Training, AN/TSQ-T1; Trainer, Handling, GM Launcher: M57; Trainer, Launch Effects, Guided Missile, M54 Transmitting Set, Infrared, M89E1 (Dragon Medium Antitank/Assault Weapon System)
NAVTRADEVVP-6054	Operator, Organizational, Direct Support, and General Support Maintenance Manual Including Parts List for Dragon Launch Environment Simulator (LES) DVC 7-71 (Can be obtained from US Army Project Manager for Training Devices, ATTN: DRCPM-TND-SLR, Orlando, Florida 32813.)

RELATED PUBLICATIONS

Related publications are sources of additional information. They are not required in order to understand this publication.

ARMY REGULATIONS (ARs)

385-11	Ionizing Radiation Protection (Licensing, Control, Transportation, Disposal, and Radiation Safety)
600-200	Enlisted Personnel Management System

COMMON TABLE OF ALLOWANCES (CTAs)

50-970	Expendable/Durable Items (Except: Medical, Class V, Repair Parts and Heraldic Items)
--------	--

DEPARTMENT OF THE ARMY LABELS (DA Labels)

80	US Army Calibrated Instrument
----	-------------------------------

INDEX

- ammunition, 1-6
- AN/TAS-5, night tracker, 1-5,1-11,2-1,3-21,3-24
- antiarmor section, 3-1
 - command and control, 3-3
 - mechanized/BFV, 3-3
 - organization, 3-1
 - role, 3-1
- armor-killer team, 3-33,3-33 (illus), 3-33 thru 3-35 (illus)
 - composition, 3-35
 - control and mobility, 3-36
 - employment, 3-33, 3-34 (illus)
 - engagement techniques, 3-36
 - mission, 3-33
 - terrain, 3-36
- attacks
 - day, 3-42
 - night, 3-43
- backblast area, 2-1, 2-2 (illus), 2-3, 7-10
- bipod, M47, 4-3
- carrying positions
 - long distance, 4-1, 4-8
 - short distance, 4-2, 4-8
- characteristics
- battery carrying container, 1-2
- capabilities, 1-1
- coolant cartridge, 1-2
- equipment data, 1-2
- mobility, 1-2
- rounds, 1-2
- tracking and controlling, 1-1
 - collective training, 5-11, 8-11
- commander's responsibility, 5-1
- components
 - ammunition, 1-6
 - day tracker, 1-2, 1-3 (illus)
 - night tracker, 1-2, 1-5, 1-5 (illus)
- DA Form 5517-R, 3-18, 3-18 (illus)
- day tracker, 1-2, 1-3 (illus)
- decontamination, principles and procedures, D-1
 - biological, D-2
 - nuclear, D-2
- defense considerations
 - cross fire, 3-30
 - depth fire, 3-30
 - fire control, 3-26,3-26 (illus)
 - methods, 3-27,3-27 (illus)
 - patterns, 3-29,3-30 (illus)
 - plans, 3-31
 - priorities, 3-29
 - sector of fire, 3-28,3-28 (illus)
 - signals, 3-31
 - target reference point, 3-28,3-29 (illus)
- destruction
 - burning, D-2, D-3
 - exploding, D-2, D-3
 - gunfire, D-2
- failure to fire
 - hangfire, 4-8, 6-16
 - misfire, 4-8, 6-16
- field handling trainer, 6-8, 6-9 (illus), 7-1, 8-2
- fighting positions, defensive, 2-3, 3-12, 3-13 thru 3-14 (illus)
 - one-man, 3-12
 - two-man, 3-14, 3-15 (illus)
- firing demonstrations, 7-2
- firing limitations, 2-3
- firing positions
 - kneeling, 7-4, 7-4 (illus)
 - prone, 7-5, 7-5 (illus), 7-7 (illus)
 - standing supported, 7-4, 7-4 (illus)
 - sitting, 7-3, 7-3 (illus)
- firing procedures, C-2
- gunner qualification with LET
 - classification and score, C-1 (table)
 - requirements, C-1
 - standards, C-2 (table)
 - verification, C-1
- gunner selection, 5-2
- gunner sustainment training, 8-9
- gunner verification with LET, C-1
- gunnery training equipment
 - AN/TSQ-1 monitoring set, 6-4, 6-5 (illus), 6-5 (illus), 6-6 (illus)
 - launch effects trainer, 6-1, 6-2 (illus), 6-3 (illus), 6-4 (illus)
 - launch environment simulator, 6-8, 6-9 (illus)
 - M89 infrared transmitting set, 6-6, 6-7 (illus)

FM 23-24

- hangfire
 - combat only, 4-8
 - training, 4-8,6-16
- infrared energy, sources of
 - fuel combustion, A-2
 - frictional, A-2
 - reflected radiance, A-2
 - solar, A-2
- infrared transmitting set, M89, 6-6,6-7 (illus)
- inspection, 4-1
- instructional techniques
 - breath control, 7-8
 - effective training, 7-1
 - M3 machine gun tripod, 7-7, 7-7 (illus)
 - M175 mount position (M113-equipped units), 7-6, 7-7 (illus)
 - M122 tripods, 7-7,7-7 (illus)
 - evaluation, 5-11
 - firing, 7-12
 - firing demonstrations, 7-2,7-3 (illus), 7-4 (illus), 7-5 (illus), 7-6 (illus)
 - range requirements, 7-9
 - sighting, aiming, and firing, 7-8
 - tracking exercises, 7-8, 7-11
- instructor
 - effective training, 7-1
 - evaluation, 5-11
 - guidelines, C-2
 - program selection, 7-1
 - selection, 5-2
 - skills and knowledge, 7-1
 - training, 6-9
 - training objectives, 6-9 thru 6-27
 - training team, 7-13
- launch effects trainer, 2-4,6 -1,6-2 thru 6-4 (illus)
- launch environment simulator, 2-4,6-8,6-9 (illus)
- misfire procedures, 2-4, 4-8, 6-16
- missile
 - flight and control, 4-7,4-7 (illus)
- monitoring set, AN/TSQ-1, 6-4, 6-5 (illus), 6-5 (illus), 6-6 (illus)
- night tracker, 1-2, 1-5, 1-5 (illus)
- obscuration
 - diesel fuel, A-3
 - dust, A-3
 - oil smoke, A-3
- offense, employment of
 - consolidation, 3-44
 - dismounted infantry platoon, 3-40
 - mechanized infantry platoon, 3-41
 - movement to contact, 3-40
 - reorganization, 3-44
- performance test
 - evaluation preparation, B-1
 - reproduction, 6-20, B-1
 - test administration, B-1
 - training objectives 1 through 11, B-2
- personnel duties
 - antiarmor section leader, 3-5
 - squad leader, 3-5
 - tasks, 3-4 (table), 3-5 (table)
 - team leader, 3-5
- precautions, general
 - Dragon/MILES, 2-5
 - equipment, 7-14
 - fighting positions, 2-3
 - firing limitations, 2-3
 - personnel, 7-14
 - round, 2-3
 - safety, LET or LES, 2-4, 7-14
 - water, 2-3
- precautions, training equipment, 2-3
 - Dragon/MILES, 2-5
 - launch effects trainer, 2-4
 - launch environment simulator, 2-4
 - target course, 6-7, 6-7 (illus)
- qualification program
 - procedures, C-2
 - program execution, 8-1
 - requirements, 8-1, C-1, C-1 (illus), C-2 (illus)
 - Dragon performance scorecard, C-3, C-3 (illus)
 - skill and knowledge requirements, 8-2
 - speed and settings, 7-13 (table)
 - time and events, 8-5
 - training, 7-12
- range determination, 3-22,3-22 thru 3-23 (illus)
- range cards
 - field-expedient, 3-19,3-19 (illus)
 - standard, 3-18, 3-18 (illus)
- recognition cues
 - BMP infantry combat vehicle, A-9, A-9 (illus)
 - BRDM-2 reconnaissance vehicle, A-10, A-11 (illus)
 - BTR-60, A-10, A-10 (illus)
 - M60A1 main battle tank, A-4, A-5 (illus)
 - M113 armored personnel carrier, A-6, A-6 (illus)
 - M551 light tank, A-5, A-5 (illus)

- T62 medium tank, A-8, A-8 (illus)
- trucks, A-7, A-7 (illus)
- retrograde, employment of
 - delaying operations, 3-37
 - infantry, 3-37
 - mechanized infantry, 3-37
 - obstacles, 3-38
 - operations, 3-37
 - reconnaissance, 3-38
- round destruction
 - burning, D-3
 - launching, D-3
 - explosives, D-3
- round, preparation for firing
 - firing positions, 4-3
 - lens cover, 4-3
 - M47 biped, 4-3
 - tracker, 4-3
- safety, LET or LES, 7-14
- scorecards
 - Dragon performance scorecard, C-3, C-3 (illus)
 - Dragon gunnery scorecard, 6-20,6-21 (illus), 6-22 (illus)
- support equipment
 - M3 machine gun tripod, 1-8, 1-9
 - M122 machine gun tripod, 1-8, 1-9
 - M175 mounting assembly, 1-8
 - vehicle storage kit, 1-10, 1-10 (illus)
- sustainment training, 7-13,8-9,8-10 (table)
- targets
 - armored vehicles, vulnerability of, 3-25, 3-25 (illus)
 - engagement, 3-22
 - fire control, 3-26,3-26 (illus)
 - recognition, 3-20,3-21 (illus)
 - techniques, 3-22
- target acquisition, 4-5,4-6 (illus)
- thermal images, A-1
- thermal targets
 - temperatures, A-1
 - images, A-1
- trackers
 - day, 1-2, 1-3 (illus)
 - night, 1-2, 1-5, 1-5 (illus)
- training, 4-8,7-12,7-13
 - 250-meters, 7-2
 - assistant gunner, 5-8
 - centralized, 5-9
 - coach, 7-13
 - collective, 8-11,8-11 (table)
 - decentralized, 5-9
 - development, 5-3
 - evaluation, 5-11
 - goals, 5-1
 - gunner, 5-8
 - gunnery, 5-9
 - individual instructions, 7-2
 - individual unit tasks and training objectives, 5-3 (table)
 - instructor, 6-9
 - leader, 5-8
 - monitoring set operator, 7-14
 - multilevel, 5-7
 - NCOIC, 7-13
 - objectives, 6-9, 1 through 15, B-2
 - officer, 7-13
 - overview, 5-2
 - platoon leader, 5-7
 - program, 5-1,5-2
 - qualification, 7-12,7-13 (table)
 - unit, 1-12, 5-1,5-3
 - unit programs, 1-12
 - schedule, 7-1
 - sequence, 7-2
 - specific needs, 5-7
 - squad leader, 5-7
 - sustainment, 7-13, 7-13 (table), 8-9,8-10 (table)
 - strategy, 1-11
 - team, 5-10,7-13
 - techniques, 5-9
 - verification, 7-13
- training team personnel, 7-14
- troubleshooting, 6-18
- verification training, 7-13
- weather conditions, 7-2
 - cold, 4-9, A-2
 - hot, 4-9
 - precipitation, A-3
 - snow, A-3

DRAGON PERFORMANCE SCORECARD

For use of this form, see FM 23-24. The proponent agency is TRADOC.
 DATA REQUIRED BY PRIVACY ACT OF 1974.
 AUTHORITY: 10 USC 3012(g)/Executive Order 9397. PRINCIPAL PURPOSE(S): Facilitates individual's training on targets at varying ranges. ROUTINE USE(S): Evaluate individual proficiency: SSN is used for positive identification purposes only. MANDATORY OR VOLUNTARY DISCLOSURE AND EFFECT ON INDIVIDUAL NOT PROVIDING INFORMATION: Voluntary. Individuals not providing information cannot be rated/scored on a mass basis.

LAST NAME			FIRST	MI	SSN				RANK	
UNIT	TEST DATE	RETEST DATE	RETEST DATE	TEST 1		TEST 2		TEST 3		
				GO	NO-GO	GO	NO-GO	GO	NO-GO	
1. MAINTAIN THE M47 MEDIUM ANTITANK WEAPON										
2. PREPARE THE M47 FOR FIRING										
3. RESTORE THE M47 TO CARRYING										
4. DEMONSTRATE CORRECT FIRING POSITIONS										
5. DETERMINE IF TARGETS ARE ENGAGEABLE										
6. PERFORM IMMEDIATE-ACTION PROCEDURES										
7. PREPARE AN ANTIARMOR RANGE CARD										
8. CONSTRUCT A FIGHTING POSITION										
9. IDENTIFY ARMORED VEHICLES										
10. EXPLAIN EMERGENCY DESTRUCTION PROCEDURES										
11. EXPLAIN EMERGENCY DECONTAMINATION PROCEDURES										

- NOTES:
1. The instructor and Dragon gunners must pass all tasks.
 2. A student should be eliminated from training if he fails to meet performance standards on any task after three attempts.
 3. The instructor places his initials in the GO, NO-GO column.

TEST NO.	QUALIFIED	UNQUALIFIED	INSTRUCTOR'S SIGNATURE
TEST 1			
TEST 2			
TEST 3			

DRAGON GUNNERY SCORECARD (CIRCLE ONE) I II III IV V VI

For use of this form, see FM 23-24. The proponent agency is TRADOC.

DATA REQUIRED BY PRIVACY ACT OF 1974.

AUTHORITY: 10 USC 3012(g)/Executive Order 9397. PRINCIPAL PURPOSE(S): Facilitates individual's training on targets at varying ranges. ROUTINE USE(S): Evaluate individual proficiency. SSN is used for positive identification purposes only. MANDATORY OR VOLUNTARY DISCLOSURE AND EFFECT ON INDIVIDUAL NOT PROVIDING INFORMATION: Voluntary. Individuals not providing information cannot be rated/scored on a mass basis.

LAST NAME	FIRST	MI	RANK	SSN	UNIT
-----------	-------	----	------	-----	------

WEATHER: (CIRCLE ONE) CLEAR FOG RAIN SNOW HAIL	DAY TRACKER _____ NIGHT TRACKER _____ MOPP LEVEL _____ OBSCURATION _____
---	---

SITTING _____ STANDING SUPPORTED _____ KNEELING _____ PRONE _____ MIXED _____
 M175 _____ M122 _____ M3 _____ INSTRUCTION _____ QUALIFICATION _____

TRACK	HIT	MISS	QUADRANT ERROR				METER SCORE		TARGET		MONITOR SWITCH
			LEFT	RIGHT	UP	DOWN	VERT	HORZ	MPH	DIR	
1											
2											
3											
4											
5											
6											
7											
8											
9											
10											
11											
12											
13											
14											
15											
16											
17											
18											
19											
20											

TOTAL		SCORER'S SIGNATURE _____ GUNNER'S SIGNATURE _____	DATE _____
--------------	--	--	------------

QUALIFICATION _____	0-31 UNQUALIFIED 32-35 FIRST CLASS 36-40 EXPERT
------------------------	---

FM 23-24
3 APRIL 1990

By Order of the Secretary of the Army:

CARL E. VUONO
General, United States Army
Chief of Staff

Official:

WILLIAM J. MEEHAN II
Brigadier General, United States Army
The Adjutant General

DISTRIBUTION:

Active Army, USAR, and ARNG: To be distributed in accordance with DA Form 12-11 E, requirements for TC 23-24, Dragon Medium Antitank Assault Weapon System M47 (Qty rqr block no. 1338).

U. S. GOVERNMENT PRINTING OFFICE :1994 O-161-026